

**STUDENT LEARNING, RETENTION, AND TRANSFER
FROM TRIGONOMETRY TO PHYSICS**

by

DARRYL JOHN OZIMEK

B.S., Clarion University of Pennsylvania, 2000

A THESIS

Submitted in partial fulfillment of the

Requirements for the degree

MASTER OF SCIENCE

Department of Physics

College of Arts and Sciences

KANSAS STATE UNIVERSITY

Manhattan, Kansas

2004

Approved by:

**Major Professor
N. Sanjay Rebello**

**STUDENT LEARNING, RETENTION, AND TRANSFER
FROM TRIGONOMETRY TO PHYSICS**

by

DARRYL JOHN OZIMEK

B.S., Clarion University of Pennsylvania, 2000

A THESIS

Submitted in partial fulfillment of the

Requirements for the degree

MASTER OF SCIENCE

Department of Physics

College of Arts and Sciences

KANSAS STATE UNIVERSITY

Manhattan, Kansas

2004

Approved by:

**Major Professor
N. Sanjay Rebello**

ABSTRACT

Transfer of learning is often referred to as one of the main goals of education. While previous research has investigated transfer of learning from some other areas of mathematics to physics, there has been virtually no significant research on transfer of learning from trigonometry to physics. This research investigated students' learning, retention, and transfer from a trigonometry course at Kansas State University to an algebra-based introductory physics course at the same institution. This research will assist both researchers and educators in how to assess and enhance transfer of learning from mathematics to physics courses.

The study used a quantitative design of a multiple-choice survey that was distributed as a pre-instruction and post-instruction assessment. The survey consisted of questions pairs, mathematics (abstract trigonometry questions) and physics (trigonometry questions in a physics context), at three hierarchical levels of mathematical thinking. Four versions of the survey were distributed to students to explore the effects of question order to guide future research. A qualitative design supplemented the surveys for a more in-depth investigation of transfer of learning. Three semi-structured interviews used graduated-prompting to determine the ease at which students transfer what they have learned from mathematics (abstract) questions to similar physics (contextual) questions.

Quantitative and qualitative results indicate that student mathematical thinking of trigonometric concepts occurs at different levels. Concepts at a lower level of thinking are retained and transferred to a greater degree than the more difficult concepts (higher levels). Transfer of learning was observed from the perspectives of both the traditional as well as the contemporary models of transfer. Question order effects appeared and have a

statistically significant effect on student responses to the multiple-choice surveys and therefore affect transfer of learning. Prompting students with various levels of specificity result in both negative and positive transfer between trigonometry and physics. This study has implications for instruction of both trigonometry and physics as well as suggestions for improving transfer of learning from one area to another.

TABLE OF CONTENTS

<u>CHAPTER</u>	<u>PAGE</u>
LIST OF FIGURES	v
LIST OF TABLES	vii
ACKNOWLEDGMENTS	ix
DEDICATION	x
1 INTRODUCTION	1
1.1. PREVIOUS RESEARCH	1
1.2. PURPOSE OF THE RESEARCH	2
1.3. RESEARCH QUESTIONS	3
1.4. OTHER RELEVANT ISSUES	8
1.5. SUMMARY	9
2 REVIEW OF LITERATURE	10
2.1. WHAT IS TRANSFER OF LEARNING?	10
2.2. DIMENSIONS OF TRANSFER	10
2.3. MODELS OF TRANSFER	12
2.4. FACTORS THAT INFLUENCE TRANSFER	14
2.5. ASSESSMENT OF TRANSFER	17
2.6. ASSESSMENT OF LEARNING IN MATHEMATICS	20
2.7. ASSESSMENT OF LEARNING IN PHYSICS	22
2.8. IMPLICATION FOR THIS STUDY	24
3 METHODOLOGY	26
3.1. CHAPTER OVERVIEW	26
3.2. SURVEY METHODOLOGY	27
3.2.1. Theoretical Basis of Survey Questions	27
3.2.2. Survey Questions	31
3.2.3. Survey Demographics and Administration	35
3.2.4. Overall Survey Analysis	38

3.3.	INTERVIEW METHODOLOGY	45
3.3.1.	Interview Protocol, Questions, and Supplementary Figures/Equations....	45
3.3.2.	Interview Demographics and Administration.....	47
3.3.3.	Analysis of Interview Data	49
3.4.	ADDRESSING THE RESEARCH QUESTIONS	50
4	RESULTS AND DISCUSSION	57
4.1.	SURVEYS	57
4.1.1.	Overall Results.....	57
4.1.2.	Reliability.....	61
4.1.3.	Individual Test Items	64
4.1.4.	Question Order Effects	71
4.1.5.	Addressing the Research Questions.....	72
4.2.	INTERVIEW RESULTS AND DISCUSSION.....	93
4.2.1.	First Set of Interviews.....	93
4.2.2.	Second Set of Interviews	107
4.2.3.	Third Set of Interviews	115
5	CONCLUSION	127
5.1.	RESPONSE TO RESEARCH QUESTIONS.....	127
5.2.	RECOMMENDATIONS FOR FUTURE RESEARCH.....	138
5.3.	IMPLICATIONS FOR INSTRUCTION.....	139
6	REFERENCES.....	142
	APPENDIX A DEMOGRAPHIC AND INTERVIEW REQUEST FORM	149
	APPENDIX B INTERVIEW CONSENT FORMS.....	150
	APPENDIX C PILOT SURVEY.....	152
	APPENDIX D PRE-INSTRUCTION SURVEYS.....	163
	D.1 VERSION 1	164
	D.2 VERSION 2	172
	D.3 VERSION 3	180
	D.4 VERSION 4	188

APPENDIX E POST-INSTRUCTION #1 SURVEYS.....	197
E.1 VERSION 1	198
E.2 VERSION 2	202
E.3 VERSION 3	206
E.4 VERSION 4	210
APPENDIX F POST-INSTRUCTION #2 SURVEYS	214
F.1 VERSION 1	215
F.2 VERSION 2	221
F.3 VERSION 3	227
F.4 VERSION 4	233
APPENDIX G FIRST INTERVIEW	239
G.1 PROTOCOL (PILOT-TEST)	239
G.2 QUESTIONS (PILOT-TEST)	243
G.3 FIGURES (PILOT-TEST).....	244
G.4 PROTOCOL.....	247
G.5 EQUATION SHEET	250
G.6 QUESTIONS.....	251
G.7 FIGURES	252
APPENDIX H SECOND INTERVIEW	255
H.1 PROTOCOL (PILOT-TEST)	255
H.2 EQUATION SHEET (PILOT-TEST)	259
H.3 QUESTIONS (PILOT-TEST)	260
H.4 FIGURES (PILOT-TEST).....	262
H.5 PROTOCOL.....	266
H.6 EQUATION SHEET	270
H.7 QUESTIONS.....	271
H.8 FIGURES	273
APPENDIX I THIRD INTERVIEW	277
I.1 PROTOCOL (PILOT-TEST).....	277

I.2 EQUATION SHEET (PILOT-TEST).....	282
I.3 QUESTIONS (PILOT-TEST).....	283
I.4 EQUATION 01 (PILOT-TEST)	285
I.5 PROTOCOL	286
I.6 EQUATION SHEET	291
I.7 QUESTIONS	292
I.8 EQUATION 01.....	294

LIST OF FIGURES

<u>FIGURE</u>	<u>PAGE</u>
Figure 1.1 Survey Analysis Methodology	2
Figure 3.1 Student Knowledge at the Geometric Level.....	29
Figure 3.2 Student Knowledge at the Unit Circle Level.....	29
Figure 3.3 Student Knowledge at the Function Level	30
Figure 4.1 Pre- and Post-Instruction Survey Score Distribution of Overall Sample.....	58
Figure 4.2 Pre- and Post-Instruction Survey Mean Scores per Version.....	60
Figure 4.3 Trigonometry Course Grades Distribution.....	74
Figure 4.4 Student Learning on On-Line Trigonometry Homework Assignments per Van Hiele Level.....	75
Figure 4.5 Pre-Instruction Survey Mathematics (Abstract) Question Results per Van Hiele Level.....	78
Figure 4.6 Pre-Instruction Survey Scores and Time between Courses.....	79
Figure 4.7 Pre-Instruction Survey Mathematics (Abstract) Question Scores per Van Hiele Level and Time between Courses	80
Figure 4.8 Question 01 of the First Pilot Interview	95
Figure 4.9 Question 01 of the First Interview	96
Figure 4.10 Figure 01 of the First Interview.....	96
Figure 4.11 Figure 02 of the First Interview.....	97
Figure 4.12 Response One to First Interview Question 01 Part (d).....	99
Figure 4.13 Response Two to First Interview Question 01 Part (d).....	100

Figure 4.14	Question 02 of the First Interview	102
Figure 4.15	Figure 03 of the First Interview	103
Figure 4.16	Figure 04 and 05 of the First Interview	104
Figure 4.17	Question 01 of the Second Interview	108
Figure 4.18	Figures 01 through 03 of the Second Interview	109
Figure 4.19	Question 02 of the Second Interview	111
Figure 4.20	Figures 04 and 05 of the Second Interview	112
Figure 4.21	Question 01 of the Third Interview	116
Figure 4.22	Question 02 parts (a) through (g) in the Third Interview	120
Figure 4.23	Question 02 - part (h) in the Third Interview	124

LIST OF TABLES

<u>TABLE</u>	<u>PAGE</u>
Table 2.1 Summary of Theoretical Perspectives on Transfer.....	13
Table 2.2 Traditional Research Design for Transfer Experiments	18
Table 3.1 Pilot Survey Question Sets, Categories, Van Hiele Levels, and Sources.....	32
Table 3.2 Pre–Instruction Survey (Version 1) Question Sets, Categories, Van Hiele Levels, and Sources	33
Table 3.3 Question Order of Pre– and Post–Instruction Survey Versions	34
Table 3.4 Pre– and Post–Instruction Survey (Version 1) Question Sets, Categories, and Van Hiele Levels	34
Table 3.5 Students Surveyed.....	35
Table 3.6 Demographic Information of the Trigonometry Sample Surveyed.....	35
Table 3.7 Interpreting Discrimination Index Values	43
Table 3.8 Demographic Information of the Students Interviewed	48
Table 4.1 Overall Survey Results	59
Table 4.2 Overall Mean Survey Results	59
Table 4.3 Pre–Instruction Survey ANOVA Summary for Survey Versions	60
Table 4.4 Post–Instruction #1 Survey ANOVA Summary for Survey Versions.....	60
Table 4.5 Post–Instruction #2 Survey ANOVA Summary for Survey Versions.....	61
Table 4.6 Survey Reliability	62
Table 4.7 Individual Test Item Results of Pre– and Post–Instruction Surveys	65
Table 4.8 Item Difficulty Index Differences.....	67

Table 4.9 Item Discrimination Indices.....	69
Table 4.10 Item Reliability	70
Table 4.11 Question Order Effects	72
Table 4.12 Van Hiele Levels of the On–line Trigonometry Homework Assignments ...	76
Table 4.13 Van Hiele Level Retention Results.....	81
Table 4.14 On–Line Trigonometry Assignments and Survey Physics (Contextual) Question Total Scores.....	83
Table 4.15 On–Line Trigonometry Assignments and Pre–Instruction Survey Physics (Contextual) Questions Total Score.....	83
Table 4.16 On–Line Trigonometry Assignments and Survey Physics (Contextual) Question Score per Van Hiele Level	84
Table 4.17 Trigonometry Course Grades and Survey Physics (Contextual) Question Score	85
Table 4.18 On–Line Trigonometry Assignments and Gain in Survey Physics (Contextual) Questions per Van Hiele Level.....	87
Table 4.19 Pre–Instruction Survey Mathematics (Abstract) Questions and Gain in Survey Physics (Contextual) Questions per Van Hiele Level	88
Table 4.20 Pre– and Post–Instruction Survey Question Correlations.....	91
Table 4.21 Pre– and Post–Instruction Survey Gain and per Van Hiele Levels	92

ACKNOWLEDGMENTS

In sincere gratitude I would like to acknowledge and thank:

- all of the students who participated in this research study. Their willingness and efforts made this project possible.
- N. Sanjay Rebello, my advisor, for infinite hours of help and guidance. His contribution to my professional growth as an educator and researcher is greatly appreciated. I would not be here without you.
- Larry Weaver and Tim Bolton, my committee members, for their guidance and support.
- all current and past members of the Physics Education Research Group for their wisdom and encouragement. Good luck to you all.
- Andrew Bennett for his guidance and support when discussing mathematics education.
- Paula V. Engelhardt for her guidance, support, and willingness to help at any time with this research study.
- my parents, Lawrence & Shirley, and my family. I could not have survived without your love, inspiration, and support. I am especially grateful to my grandparents, John & Victoria and John & Ann, and to my uncle, Charles, for their guidance and support throughout this project. Your love and compassion helped make me who I am today. “Thank you” does not say enough.
- the U.S. National Science Foundation for their support in part of funding the Grant# DUE-0206943.

DEDICATION

I dedicate this work to my wife and best friend, Cynthia. Thank you for everything!!!!

CHAPTER 1

INTRODUCTION

1.1. PREVIOUS RESEARCH

Transfer of learning is a topic of interest for many educational researchers. However, there has been no significant research on transfer of learning from trigonometry to physics. Therefore, transfer of learning from trigonometry to physics is the central focus of this thesis

Traditionally, transfer of learning is often (Reed, 1993; Singley and Anderson, 1989) defined as applying what one has learned in one situation to another situation. Due to the lack of evidence of transfer in many studies based on traditional models, recent views of transfer (contemporary or modern-day models) have shifted to look at transfer from other perspectives.

Traditional models (Bassok, 1990; Chen and Daehler, 1989; Adams, Kasserman, Yearwood, Perfetto, Bransford, and Franks, 1988; Brown and Kane, 1988; Novick, 1988; Nisbett, Fong, and Cheng, 1987; Perfetto, Bransford, and Franks, 1983; Reed, Ernst, and Banerji, 1974; Wertheimer, 1959; Thorndike and Woodworth, 1901a) are based on a researchers pre-defined concept which they hope students would transfer. These models also view transfer as a static, passive process. Contemporary models of transfer (Lobato, 2003; Bransford and Schwartz, 1999; Lobato, 1996; Greeno, Moore, and Smith, 1993) account for aspects the traditional models neglect (i.e. socio-cultural, available resources during the initial learning situation) by viewing transfer from the students' point of view and also as an active, dynamic process during which students learn.

1.2. PURPOSE OF THE RESEARCH

The purpose of this research study is to examine student learning, retention, and transfer from trigonometry to physics. The students in this study were enrolled in an algebra-based introductory physics course. To answer the research questions (see Section 1.3), our efforts are focused on students that previously completed a trigonometry course.

Figure 1.1 provides a schematic overview of various aspects of this study.

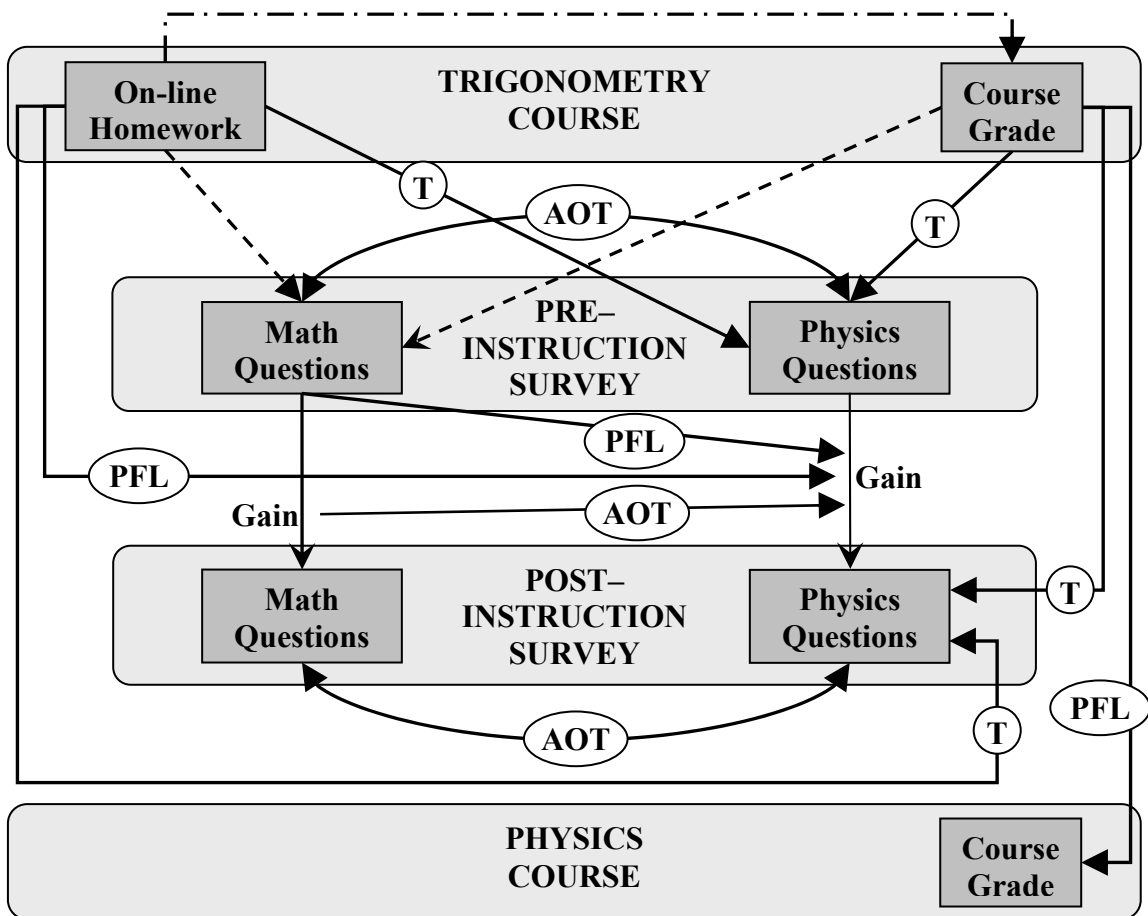

Figure 1.1 Survey Analysis Methodology

The lightly shaded rounded rectangles indicate the main sources of data collected for this research; trigonometry course data, pre- and post-instruction surveys, and physics course

data. The dashed line with dots in between [- · - ·] represents how we assessed student learning in trigonometry. The dashed lines [- - - -] represent how we assessed what knowledge students retain after a trigonometry course. The solid lines [———] refer to the different ways we assessed transfer of learning. These assessments are discussed in further detail in the next section (1.3).

1.3. RESEARCH QUESTIONS

Research Question # 1: What concepts have the students learned in the trigonometry courses?

To answer this research question, data were collected from the assessments used in the trigonometry course. These data include on–line homework assignments and course grades. The assessment of student learning is indicated by the dashed line with dots in between [- · - ·] in Figure 1.1. We correlated the on–line homework assignments with the course grades to assess the amount of learning in trigonometry.

To measure conceptual understanding in trigonometry, three hypothesized Van Hiele Levels (VHL's) for trigonometry were used. Van Hiele (1986) describes five levels of thinking for geometry that are in a hierarchic arrangement (i.e. thinking at the second level is not possible unless you are able to think at the first level). Similarly, the VHL's for trigonometry consist of three hierarchical levels of thinking. To gain deeper insights into what specific concepts the students learned in the trigonometry course, the first six on–line homework assignments were categorized into three VHL's for thinking in trigonometry. Student maximum scores divided by the number of attempts were calculated for each homework assignment. These values were averaged for each VHL

and a t -test was used to determine whether the differences in student learning for the VHL's are statistically significant.

Additional data were requested of student grades for each question on the final exam, which would have been classified to VHL's accordingly, to measure what specific material the students have learned in their trigonometry course. Due to time constraints, the final exam data were not obtained.

Research Question # 2: What knowledge do the students retain from their trigonometry course when they begin their physics course?

To answer this research question, data were collected from the assessments used in the trigonometry course and the pre-instruction survey mathematics (abstract trigonometry questions) questions. The assessments of student retention are indicated by the dashed lines [- - - -] in Figure 1.1.

Since data were collected while students were enrolled in an algebra-based introductory physics course (*General Physics 1*) after they completed a *Trigonometry* course, a survey was designed to determine what knowledge the students retained. To measure conceptual understanding in trigonometry, the survey questions were based on Van Hiele Levels (VHL's) for trigonometry. The survey questions consisted of mathematics (abstract trigonometry questions) questions where many were identical to questions in the trigonometry course textbook, as well as physics (trigonometry questions in a physics context) questions. However, it was the mathematics questions that pertained to Research Question # 2.

We examined the correlation between student performance on the on-line trigonometry homework assignments and the amount of trigonometry knowledge retained, which was measured by their performance on the pre-instruction survey mathematics (abstract) questions, before they began their physics course. Because the survey questions were designed based on VHL's for trigonometry, we were also able to measure what level of trigonometry knowledge the students retained. In a similar fashion, trigonometry course grades were also used to determine how much and what level of knowledge the students retain after completing a trigonometry course. In addition to surveys, we further investigated student retention of trigonometry knowledge using semi-structured interviews.

Research Question # 3: How consistently do students use their understanding developed in trigonometry courses when encountering these ideas in new contexts? More specifically, is it easier for students to transfer certain mathematical concepts/representations and skills than others to a given physical context?

We consider this research question to be the main focus of this research study. The quantitative and qualitative data discussed above provides the basis for which we will determine whether or not students transfer their learning from trigonometry to physics. As in the design of the survey with three hierarchical VHL's for trigonometry, we will observe which trigonometric concepts transfer easier to a given physical context. To answer this research question, data were collected from the assessments used in the trigonometry course, the pre- and post-instruction surveys, and the physics course. The data used to assess transfer of learning are indicated by the solid lines [———] in

Figure 1.1. The ovals indicate which model of transfer is being assessed – ‘T’ (traditional perspective) for traditional model of transfer; ‘PFL’ (preparation for future learning perspective) and ‘AOT’ (actor-oriented transfer perspective) for contemporary models of transfer.

Traditional (T) models (e.g. Reed, 1993; Singley and Anderson, 1989) focus on whether or not students are able to transfer a pre-defined concept which researchers hope the students would transfer. The researchers look for evidence that students have been able to transfer the pre-defined concept from a context in which the concept was initially learned to a new context – a passive, static process. The traditional model of transfer was assessed by correlating the relevant (first six) on-line homework assignments with the pre- and post-instruction survey physics (contextual) questions. To gain a deeper insight to what knowledge the student’s transfer, individual on-line homework assignments were correlated with the pre- and post-instruction survey physics questions. In order to assess what specific concepts students transfer, the on-line homework assignments were categorized into VHL’s and correlated with the corresponding VHL pre- and post-instruction survey physics questions. Also, the trigonometry course grades were correlated with the overall pre- and post-instruction survey physics (contextual) questions. To further assess the specific knowledge student’s transfer from trigonometry to physics, the trigonometry course grades were correlated with the VHL physics (contextual) questions on the pre- and post-instruction surveys.

The preparation for future learning (PFL) perspective (Bransford and Schwartz, 1999) – contemporary model – focuses on whether the initial learning helps students *learn* to solve problems in the new situations with the opportunity to utilize resources (i.e.

texts, colleagues, feedback) they may have had available during initial learning. The PFL perspective of transfer was assessed by correlating the on-line homework assignments and pre-instruction survey mathematics (abstract) questions with the gain in survey physics (contextual) questions. In order to assess which specific concepts students transfer from the PFL perspective, the on-line homework assignments, pre-instruction survey mathematics questions, and gain in survey physics questions were categorized into VHL's and correlated. The *Trigonometry* course grades were also correlated with the *General Physics 1* (GP1) course grades. Another aspect of the PFL perspective is the types of questions students generate as they attempt to solve a problem. Thus, the interview data were analyzed to determine whether or not the protocol questions prompt students to transfer their learning by helping them generate relevant questions.

The actor-oriented transfer (AOT) perspective (Lobato, 2003) – contemporary model – argues that traditional models look for improved performance as a measure of transfer while the actor-oriented perspective examines transfer by looking at the nature of situations and the similarities that people construct across the situations. Evidence for transfer is gathered by scrutinizing a given activity for any indication of influence from previous activities rather than predetermining which responses count as evidence of transfer and which do not (Lobato, 2003). The actor-oriented perspective of transfer of learning was assessed by several measures. First, the survey was designed to observe whether or not students transfer trigonometric concepts within the survey itself – i.e. from one question to another. This is possible due to question sets within the survey. Each question set consists of two isomorphic questions categorized as ‘M’ for the abstract mathematics question or ‘P’ for the contextual physics question. Both the ‘M’ and ‘P’

questions in each set address the same underlying trigonometric concept. However, the ‘M’ question requires no knowledge of physics, where as the ‘P’ questions assess the trigonometric concept in a physics context. Correlations between the pre–instruction survey mathematics (abstract) and physics (contextual) questions assess transfer of learning from the actor–oriented perspective. The correlation was repeated for the post–instruction survey questions as well. The gain in mathematics and physics survey questions was also correlated. Another measure of transfer from the actor–oriented perspective considered in this study is whether students’ refer to their solution of a mathematics problem in the interview as they work through the corresponding physics problem.

1.4. OTHER RELEVANT ISSUES

Research (Gray, 2004) has shown instances on pre– and post–instruction multiple–choice surveys that the order of questions influenced the frequency of students’ responses. Gray has also shown that the type of question preceding the question of interest was more important than the actual location of a question on the survey. In an effort to help guide future research, four versions of the survey were distributed to the overall sample of students in the *General Physics I* course. The versions consisted of identical questions; the only difference between versions is in the order in which questions were presented. We did not control student progress through the survey; therefore students could go back to previous questions while they were completing the survey. If there are statistically significant question order effects, some of the data that shows order effects may bias the results. A more detailed discussion of the order effects is beyond the scope and purpose

of this study; however, it provides fodder for future research with an interesting topic as well as something educators should consider when administering multiple versions of homework or exams.

1.5. SUMMARY

The overarching goal of this study is to investigate student transfer from trigonometry to physics in terms of our Van Hiele Levels for trigonometry. Mathematical thinking in terms of Van Hiele Levels is just one method to measure conceptual understanding in trigonometry. Research in the area of transfer from trigonometry to physics has not been widely investigated. This research provides one way to look at transfer of learning from trigonometry to physics and a foundation for future research. Both traditional as well as contemporary perspectives of transfer of learning have been utilized. While the study is primarily quantitative in nature, qualitative data from semi-structured interviews have been used to gain deeper insights into some of the quantitative results.

CHAPTER 2

REVIEW OF LITERATURE

2.1. WHAT IS TRANSFER OF LEARNING?

Transfer of learning is often (Reed, 1993; Singley and Anderson, 1989) defined as applying what one has learned in one situation to another situation. The principle that people learn by using what they know can be paraphrased as “all learning involves transfer from previous experiences” (Bransford, Brown, and Cocking, 1999).

There are some differences between traditional and contemporary views of transfer of learning. Traditional models (Bassok, 1990; Chen and Daehler, 1989; Adams et al., 1988; Brown and Kane, 1988; Novick, 1988; Nisbett et al., 1987; Perfetto et al., 1983; Reed et al., 1974; Wertheimer, 1959; Thorndike and Woodworth, 1901a) view transfer from a pre-defined researcher’s point of view and as a passive, static process where students apply their prior knowledge of the initial learning situation to the new situation (the situation in which transfer is expected to occur). Contemporary models (Lobato, 2003; Bransford and Schwartz, 1999; Lobato, 1996; Greeno et al., 1993) view transfer from the students’ point of view and as an active, dynamic process where students construct a knowledge structure in the new situation.

2.2. DIMENSIONS OF TRANSFER

Transfer of learning is often distinguished along three dimensions (Lobato, 1996): 1) near/far, 2) vertical/lateral, and 3) structure/surface. Near transfer occurs when the initial

learning situation is nearly identical to the new situation, i.e. solving for a side of a right triangle and solving for an angle of a right triangle. Far transfer occurs when the initial learning situation is substantially different from the new situation, i.e. solving for an angle of a right triangle in a trigonometry course and solving for the slope (angle) of staircase risers that the student may be constructing.

Vertical transfer occurs when a students' existing knowledge is used to construct new knowledge, i.e. solving sides of a right triangle in trigonometry and then resolving force components in physics. Another example of vertical transfer is using skills of writing letters of the alphabet to write words (Bransford et al., 1999). Lateral transfer occurs when a student uses existing knowledge over a variety of situations at roughly the same complexity, i.e. solving multiple right triangle problems. An example of a study involving lateral transfer is described by the missionaries–cannibals and jealous–husbands problems (Reed et al., 1974). The researchers assumed a formal mapping existed between the two problems and therefore the two problems were good candidates for transfer because of their similarities at both a surface (story content) and formal (search space) level. The results showed only when subjects were explicitly told the relation between the two problems did significant transfer occur.

The third dimension pertains to similarities between the learning and transfer situations (see Singley and Anderson, 1989; Resnick and Ford, 1981). Surface similarities exist between situations that share only external likeness such as two words that have the same letters mixed–up, e.g. ‘unclear’ and ‘nuclear’, but might be completely different in meaning. Deep structure similarities exist between two situations that may appear completely different to the novice learner, but are governed by the same principles

or concepts such as two words that are completely different in sound and letters, but are synonyms e.g. ‘unclear’ and ‘vague’.

When transfer is discussed, greater interest usually is in far transfer of deep structure rather than near transfer of surface features. This research is primarily concerned with transfer from mathematics to physics contexts, which would be categorized as far transfer because the mathematics and physics courses seldom share the same content. We are also primarily interested in transfer between problems that share the same deep structure rather than surface features.

2.3. MODELS OF TRANSFER

A thorough review of transfer literature until the mid 1990’s has been provided by Lobato (1996). This section briefly describes the theoretical perspectives discussed by Lobato and includes more recent perspectives on transfer of learning. According to Lobato (1996), at the root of any theory of transfer is the notion of invariance, or what causes two situations to be the same. The theoretical perspectives on transfer can broadly be categorized into traditional and contemporary models of transfer as shown in Table 2.1.

Model	Theoretical Perspective	Source of Invariance
Traditional	Theory of Identical Elements (Thorndike)	Surface features of the physical environment
	Theory of Deep Structure (Judd)	Understanding a principle
	Information–Processing Perspective	Symbolic mental representations
Contemporary	Social–Cultural Perspective	Social and cultural environment: language, cultural artifacts, structuring by more knowledgeable others
	Transfer in Terms of Affordances and Constraints of Activity (Greeno <i>et al.</i>)	Interaction of person and material resources
	Actor–Oriented Transfer Perspective (Lobato)	Personal creations of similarity by the learner
	Preparation for Future Learning (Bransford and Schwartz)	No specific source of invariance. Could be any.

Table 2.1 Summary of Theoretical Perspectives on Transfer

The traditional models of transfer have tended to focus on the cognitive aspects of transfer. Thorndike’s theory of identical elements asserts that training in one kind of activity transfers to another only if the activities share common elements; which are generally taken to mean identical at the level of the surface features of the stimulus environment (Thorndike and Woodworth, 1901a). Judd’s theory of deep structure claims that transfer is determined by the extent to which the learner is aware of underlying shared causal principles between two problems or situations (Judd, 1908). As per the information processing perspective, transfer is mediated by abstract, symbolic mental representations (Singley and Anderson, 1989). The learner constructs an abstract mental representation or schema through experiences in the learning situation and deploys the schemas in the transfer situation.

Contemporary models of transfer have gone beyond focusing solely on the cognitive aspects of transfer. Rather they have included several other mediating factors

that affect transfer. The socio-cultural perspective asserts that the social and cultural environment effects transfer through language, cultural tools, and more knowledgeable others. Transfer in terms of affordances and constraints of activity focus on the extent to which participating in an activity while being attuned to the affordances and constraints in one situation influences the learners' ability to participate in a different situation (Greeno et al., 1993). The actor-oriented perspective conceives transfer as the personal construction of similarities between activities (how actors, i.e. learners, see situations as similar) (Lobato, 2003). Preparation for future learning focuses on whether students can *learn* to solve problems in transfer situations in a similar way in which they initially learned the content, i.e. using available resources (Bransford and Schwartz, 1999).

2.4. FACTORS THAT INFLUENCE TRANSFER

Several factors may have either positive or negative consequences on transfer of learning. The degree of mastery of the material in the learning context often predicts whether transfer might occur (Bransford et al., 1999). For instance, we believe that the degree of students' mastery attained in the trigonometry class can influence the extent to which they can transfer their trigonometry knowledge to physics.

Another major factor influencing transfer is students' ability to construct a coherent schema in the learning situation in a variety of different contexts (Novick and Holyoak, 1991; Holyoak, 1984). The more a student understands the concept, the more likely s/he is able to transfer that concept to other situations in school as well as non-school environments. For instance, understanding how to use the sine rule in triangles will positively affect transfer rather than students' ability to memorize the sine formula.

The amount of time a student spends in learning also influences the degree at which the student may transfer their knowledge to a new situation (Singley and Anderson, 1989). Monitoring ones own learning takes time, but research (Ericsson, Krampe, and Tesch-Romer, 1993) has shown learning is most effective when people engage in “deliberate practice” that includes active monitoring of one’s learning experiences.

Transfer can be improved when abstract logical arguments are embodied in concrete contexts (see Wason and Johnson-Laird, 1972). A number of studies converge on the conclusion that transfer is enhanced by helping students see potential transfer implications of what they are learning (Anderson, Reder, and Simon, 1996). Thus, educators might promote transfer by pointing out the usefulness of abstract trigonometric identities in physics, engineering, or other real–life applications.

Feedback has been linked to play a critical role for successful learning (Thorndike, 1913). A type of feedback that has been utilized in academia is the use of “contrasting cases” (Garner, 1974; Gibson and Gibson, 1955; Gagné and Gibson, 1947). Providing cases for students that contrast to previous learning may help them become aware of features that may not have been noticed in the old situation or not present in their mind when presented with the new situation. Understanding when, where, and why to use new knowledge may be enhanced through the use of “contrasting cases” (Bransford et al., 1999). In this study we use a variation of contrasting cases when we present students with isomorphic problems that share the same ‘deep structure’ i.e. underlying concept, but are different in surface features, i.e. one is an abstract mathematical problem and the other is a contextual physics problem. We examine

whether students are able to transfer their knowledge from trigonometry to physics by asking them to compare the two questions.

Transfer is also affected by the context of original learning; people can learn in one context, yet fail to transfer to other contexts (Bransford et al., 1999). How tightly learning is tied to contexts depends on how the knowledge is acquired (Eich, 1985). Research (Bjork and Richardson-Klavhen, 1989) has shown transfer across contexts is especially difficult when a subject is taught only in a single context rather than in multiple contexts. When a subject is taught in multiple contexts and includes examples that demonstrate wide application of what is being taught, people are more likely to abstract the relevant features of concepts and to develop a flexible representation of knowledge (Gick and Holyoak, 1983). Findings from several studies in problem based learning (Cognition and Technology Group at Vanderbilt, 1997; Hmelo, 1995; Williams, 1992; Barrows, 1985; Gragg, 1940) indicate that if students learn only in a single context, they often fail to transfer flexibly to new situations (Cognition and Technology Group at Vanderbilt, 1997). Based on this research we foresee several barriers to students transferring what they have learned in trigonometry to physics or engineering, because oftentimes students are not exposed to multiple contexts while solving typical end-of-the-chapter problems in trigonometry texts.

One of the ways to resolve the flexibility is to ask learners to solve a specific case and then provide them with an additional, similar case (Bransford et al., 1999); the goal is to help them abstract general principles that lead to more flexible transfer (Gick and Holyoak, 1983). Studies show that abstracted representations do not remain as isolated instances of events but become components of larger, related events, schemata (Novick

and Holyoak, 1991; Holyoak, 1984). Schemata are posited as particularly important guides to complex thinking, including analogical reasoning (Bransford et al., 1999): “Successful analogical transfer leads to the induction of a general schema for the solved problems that can be applied to subsequent problems” (National Research Council, 1994). Memory retrieval and transfer are prompted by schemata because they derive from a broader scope of related instances than single learning experiences (Bransford et al., 1999).

Metacognitive approaches to instruction have been shown to increase the degree to which students will transfer to new situations without the need for explicit prompting (Bransford et al., 1999). Alan Schoenfeld (1991; 1985; 1983) teaches heuristic methods for mathematical problem solving to college students, which are derived from the problem-solving heuristics of Polya (1957). As students continue to develop their resources, heuristics, control, and beliefs, they begin to ask themselves self-regulatory questions and hence, become more effective problem solvers. In our study we examine the effect of “graduated prompting” (see Section 2.5) in our interviews on students’ ability to transfer what they have learned from trigonometry to physics.

2.5. ASSESSMENT OF TRANSFER

Assessment is an essential component in any educational setting, especially when attempting to measure transfer of learning. One of the simplest experimental designs to illustrate how researchers have traditionally looked for transfer is shown in Table 2.2 (Lobato, 1996).

Group	Initial Task	Transfer Task
Experimental	A	B
Control	—	B

Table 2.2 Traditional Research Design for Transfer Experiments

The experimental group is presented with an initial learning task followed by a transfer task. Their performance is compared with that of a control group that does not perform the initial learning task. Positive transfer is evident if the experimental group performs better than the control group. The reverse is taken as evidence of negative transfer. Researchers typically use a variety of formulas to measure the amount of transfer. According to Lobato (1996), one of the simplest is Gagné’s raw score formula which is the difference between the score of the experimental group and the score of the control group on the transfer task.

Using “one-shot” assessments often underestimate the amount of transfer student’s display from one domain to another (Bransford and Schwartz, 1999; Bruer, 1993; Brown, Bransford, Ferrara, and Campione, 1983) because they are designed to focus on whether or not students are able to correctly solve the new set of problems. “One-shot” assessment techniques may ask students to solve a particular set of problems that are often quite different from concepts the students have learned during the initial learning situation. According to Singley and Anderson (1989), a more accurate measure of transfer of learning is in observing the ease with which students are able to learn how to solve the new set of problems as opposed to whether or not they could solve the problems in “one-shot.” In our research we use both the ‘one-shot’ method and

formative assessment methods that are consistent with transfer as in the preparation for future learning paradigm (Bransford and Schwartz, 1999).

Another strategy that facilitates transfer of learning directs students' attention to specific issues (Anderson et al., 1996) as the students are engaged in the transfer situation. Directing students' attention to the specific issues is often called prompting. Research (Perfetto et al., 1983; Gick and Holyoak, 1980) has shown that prompting through the use of assessment and feedback may enhance transfer of learning. In an ideal situation the student will not require any prompting. However, if transfer of learning is not occurring in the new situation, prompting may provide an increase in the amount of knowledge the student transfers.

A prompting strategy that has been developed and used during assessment and feedback situations is called "graduated prompting." Researchers (Newman, Griffin, and Cole, 1989; Campione and Brown, 1987) have used "graduated prompting" to assess the ease at which students are able to transfer their knowledge from one situation to another. The technique of "graduated prompting" may be used as an assessment strategy based on the amount of assistance the students need for transfer to the new situation. Counting the number of prompts given and the level of specificity of those prompts provide the extent to which the students are able to transfer their knowledge. In our study we have used graduated prompting in post-instruction interviews by presenting students with two questions that share the same underlying concept and prompting the student to refer to one question when they are unable to answer the other.

2.6. ASSESSMENT OF LEARNING IN MATHEMATICS

Assessment in terms of learning is complicated by the difficulty of defining exactly what has been learned. How to best define and measure conceptual understanding in mathematics has been the topic of interest by many researchers (i.e. Piaget, 1995; Freudenthal, 1991; Skemp, 1987; Van Hiele, 1986). The approaches of these authors differ in the specific details, but all focus on measuring conceptual understanding in terms of increasing levels of abstraction. The view on conceptual understanding provided by Van Hiele (1986) is a vital part to the methodology of this research project. Pierre and Dina Van Hiele began investigating what led students to develop insight into new types of problems in the 1950's. Their work developed into the "Van Hiele Levels" (VHL's) for geometry. The five levels of thinking are (as originally presented):

First level: the visual level

Second level: the descriptive level

Third level: the theoretical level; with logical relations, geometry generated according to Euclid

Fourth level: formal logic; a study of the laws of logic

Fifth level: the nature of logical laws

According to Van Hiele (1986), reasoning between the first and second levels can lead to results different from reasoning at a higher level. The transition from one level to the following is not a natural process; rather it takes place under influence of a teaching-learning program. In order to "mature" to the third level, the student must understand a network of relations between the first two levels; however, the acceptance must be voluntary – it is not possible to force a network of relations on someone. If the researcher

or educator wants to convince the students, they can accomplish the acceptance by pointing out the difficulty of producing general statements.

An example of the difference between objects of the second and third levels is demonstrated by Van Hiele (1986) in an algebra context. At the second level, calculation deals with relations between concrete numbers: i.e. $4 \times 3 = 12$, $6 + 8 = 14$. At the third level of thinking, calculation deals with generalizations of the results: i.e. $a \times (b + c) = (a \times b) + (a \times c)$. In these generalizations, students do not return to the original objects of the second level, namely concrete numbers.

The levels of thinking have a hierarchic arrangement; thinking at the second level is not possible without that of the base level; thinking at the third level is not possible without thinking at the second level, etc. Higher levels than the third level depends on the subject matter: “Different sciences like mathematics, physics, chemistry, biology, history, and linguistics have third levels each constructed in a different way” (Van Hiele, 1986).

A circumstance that affects the thinking of the real relation between levels is that of *level–reduction*. According to Van Hiele (1986), there are frequent misunderstandings about the levels of thinking; some people suppose they exist only in mathematics and even only in geometry, while others think the levels only borrow their importance from the part they play in education. Van Hiele (1986) argues that there are many advantages in using the levels of thinking when teaching some topics, for with the help of this theory you can find out where to begin with the topic you intend to teach.

In this study, we use Van Hiele Levels for trigonometry as our basis for assessing student learning in the trigonometry course, retention, and transfer to the physics course.

2.7. ASSESSMENT OF LEARNING IN PHYSICS

While the issue of conceptual assessment has been widely addressed by physics education researchers, no significant studies in transfer of learning have been completed in this area. A comprehensive review of assessment literature is beyond the scope of this section; rather this section focuses on an area in physics that has been widely assessed – mechanics. Two assessment instruments that have received attention are The Test of Understanding Graphs of Kinematics (Beichner, 1994) and the Force Concept Inventory – FCI (Hestenes, Wells, and Swackhamer, 1992).

The Test of Understanding Graphs of Kinematics (Beichner, 1994) assesses students' ability to interpret graphical representations of kinematics. Beichner uncovered a consistent set of student difficulties with their interpretations; specifically with graphs of position, velocity, and acceleration versus time. The student difficulties include misinterpretations of the following; graphs as pictures, confusion on slope and height, difficulty with finding slopes of lines that do not pass through the origin, and the lack of ability to interpret the meaning of the area under various graph curves.

The Force Concept Inventory – FCI (Hestenes et al., 1992) is the most widely used and thoroughly tested mechanics assessment instrument. Each of the 29 questions on the FCI requires students to distinguish between correct Newtonian answers and incorrect, “commonsense” beliefs (misconceptions). Many students hold incorrect beliefs, possibly due to their everyday experiences. More importantly, Newtonian choices for non-Newtonian reasons were fairly common. Widespread administration of the FCI has raised awareness to the inadequacy of traditional lecture methods to promote

conceptual learning (see Hake, 1998; Mazur, 1997). Often pre- versus post-test gains on the assessment instrument has been the standard by which the effectiveness of instruction has been gauged. Thus, from the perspective of transfer, one can argue that traditional methods of instruction do not facilitate positive transfer from the classroom to testing situations, as measured by the average gain in student performance.

Factor analysis of students' responses to the questions has caused some researchers (Huffman and Heller, 1995) to question what is actually measured by the FCI. Huffman and Heller conclude that more research is needed to determine what the FCI is actually measuring as a result of their factor analysis. Recently, Schecker and Gerdes (1999) analyzed the FCI as a tool for understanding the model that students applied in dynamics problems. They assumed that students would generally hold one of three models – Aristotelian, Impetus or Newtonian. However, the FCI did not lend itself well to such an analysis because all three models were not represented in each of the questions about forces. Schecker and Gerdes also investigated briefly how the context of the question may affect students' responses. One question on the FCI asks students to select an answer to describe forces on a golf ball after it has been hit and is traveling in the air toward a green. They modified the question slightly by replacing the golf ball with a soccer ball and found that the results changed rather remarkably. The authors conclude that the students' model is dependent on the context. Therefore from the analysis, successful transfer depends on the initial learning context.

Rebello and Zollman (2002) analyzed the effect of distracters on student performance on the FCI. The results indicated that percentages of correct responses in each of the two formats, multiple-choice FCI questions and equivalent open-ended

questions, do not adversely affect performance as measured by the number of correct answers. They further indicate that a significant percentage of the incorrect open-ended responses fall into categories that are not included in the FCI multiple choices and when those alternative categories were presented to the students as distracters in a revised multiple-choice format, a significant percentage of the students chose these alternative responses. Therefore, from the results of their study we also need to consider the manner in which a problem is represented because it may have significant implications on transfer of learning.

Most recently, Gray (2004) observed the possibility of transfer from one FCI question to another. Her study involved the effect of question order on student responses to multiple-choice physics questions. She noticed that when students were asked two related questions in an interview, they transferred what they had learned in one question to another. When students were asked two mutually related questions in a particular order, they asked to return to the first question and corrected their original answer.

2.8. IMPLICATION FOR THIS STUDY

A literature search revealed that virtually no research was found on the study of transfer from trigonometry to physics. Therefore, this study serves as a foundation for looking at transfer from trigonometry to physics in which further research may build upon. However, there are several aspects of previous research reviewed in this chapter that are relevant to this study.

We will examine transfer of learning both from the contemporary perspectives as well as from the more traditional perspectives. The latter involves a ‘one-shot’

assessment at the beginning of the physics course to test the extent to which student have retained their knowledge of trigonometry as well as the extent to which they are able to apply it in isomorphic physics problems. We will also incorporate the contemporary perspectives of transfer, e.g. “preparation for future learning” by Bransford & Schwartz (1999) as we examine how students’ prior knowledge of trigonometry affects their learning of physics. Lobato’s (2003) “actor-oriented model” of transfer will also be used to examine the dynamic transfer of learning as it occurs in surveys and interviews.

This research is cognizant of several factors that affect transfer. Most importantly we focus on the issue of the effect of context on students’ ability to apply what they have learned in the trigonometry course in solving physics problems. In our interviews we will also pay attention to the influence on transfer due to interactions with the interviewer through graduated prompting as well as the presentation of contrasting cases.

Thus, the research described in this thesis is novel in that it addresses transfer from trigonometry to physics that up until now has not been investigated. However, the research is based on well established ideas of the meaning of transfer, the factors controlling it, and the methodology to assess it.

CHAPTER 3

METHODOLOGY

3.1. CHAPTER OVERVIEW

This research study used both written surveys and semi-structured interviews to investigate retention and transfer of learning from trigonometry to physics. The surveys were administered before and after physics instruction to students in an algebra-based physics course, *General Physics 1* (GP1), at Kansas State University (K-State). Statistical measures were used as the method of analysis. To measure retention and transfer of learning, we focused on GP1 students who had previously taken *Trigonometry* at K-State. The data for the trigonometry sample was obtained from about 44 students. The surveys were based on the Van Hiele Levels (VHL's) for trigonometry, discussed in Section 3.2.1, that consist of a hierarchic arrangement of levels of thinking: the geometric level (base or first level), the unit circle level (second level), and the function level (third level). Question sets on the survey were designed to consist of mathematics (abstract) and physics (contextual) questions on trigonometry concepts. Four versions of the survey were designed and distributed to the overall sample (all GP1 students). All questions were identical between the four versions. The purpose of having four versions was to change the order of the questions, based on the research done by Gray (2004). No effort was made to keep students with graphing calculators from graphing the functions nor did we control for a particular order that students answered the questions; that is, students were able to answer the survey questions in any order.

The interviews allowed us to gain a deeper understanding of retention and transfer of learning from trigonometry to physics. The students that volunteered to participate in three interviews throughout the semester were interviewed and paid a stipend of \$30 upon completion of all three interviews. Thirteen students participated in each of the three sets of interviews. A pilot-test of the semi-structured interview protocol, physics (contextual) questions, and supplementary mathematics (abstract) questions was conducted with the first three participants for each of the three interviews. No effort was made to make the interview sample representative of the survey overall sample.

3.2. SURVEY METHODOLOGY

3.2.1. Theoretical Basis of Survey Questions

Surveys were constructed based on Van Hiele Levels (VHL's) of thinking and transfer of learning from trigonometry to physics. As discussed in the section Assessment of Learning in Mathematics (Section 2.6), VHL's provide a way of defining (or measuring) conceptual understanding in mathematics. Thus, the survey was designed with VHL's for trigonometry. A goal of the pre-instruction survey was to assess retention and transfer of learning from trigonometry to physics, a topic that has not received much attention or been widely researched.

The VHL's for trigonometry are based on the work done by Pierre and Dina Van Hiele. They began investigating what led students to develop insight into new types of problems and their work developed into the "Van Hiele Levels" for geometry. Van Hiele

demonstrated the existence of the levels of thinking by determining whether there are discontinuities between the levels (see Van Hiele, 1986, pp. 49-52).

The VHL's for trigonometry are a similar set of hierarchical levels of mathematical thinking consisting of the following levels:

First level: the geometric level (Van Hiele's visual level)

Second level: the unit circle level (Van Hiele's descriptive level)

Third level: the function level (Van Hiele's theoretical level)

At the geometric level (base or first level), there is a language, but the use of language is limited to solving for various features of a right triangle. Students thinking at the geometric level are able to solve right triangles to obtain sides and angles. At the geometric level students utilize their knowledge of basic trigonometric functions such as sine, cosine, tangent; cosecant, secant, and cotangent. The students also possess the knowledge of the Pythagorean Theorem at the geometric level.

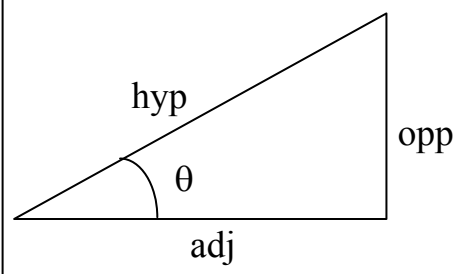
	Basic Trigonometric Functions	
<p>Pythagorean Theorem $(hyp)^2 = (adj)^2 + (opp)^2$</p>	$\sin \theta = \frac{opp}{hyp}$	$csc \theta = \frac{hyp}{opp}$
	$\cos \theta = \frac{adj}{hyp}$	$sec \theta = \frac{hyp}{adj}$
	$\tan \theta = \frac{opp}{adj}$	$cot \theta = \frac{adj}{opp}$

Students thinking at the geometric level are also able to think abstractly and solve right triangles to obtain sides and angles that are labeled with variables (see Figure 3.1).

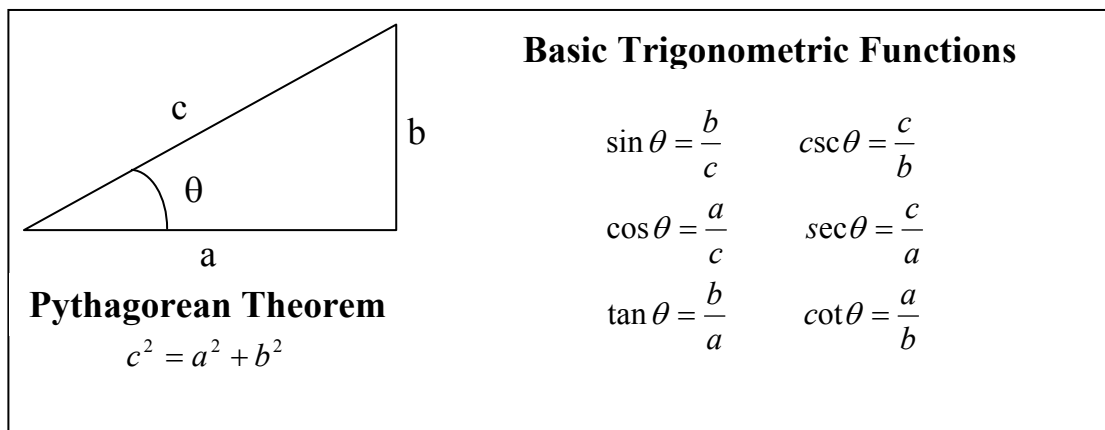

Figure 3.1 Student Knowledge at the Geometric Level

In order to think at the unit circle level, students must be able to apply trigonometric functions at the geometrical level and solve for various elements of a unit circle as shown in Figure 3.2 (adapted from Swokowski and Cole, 1999).

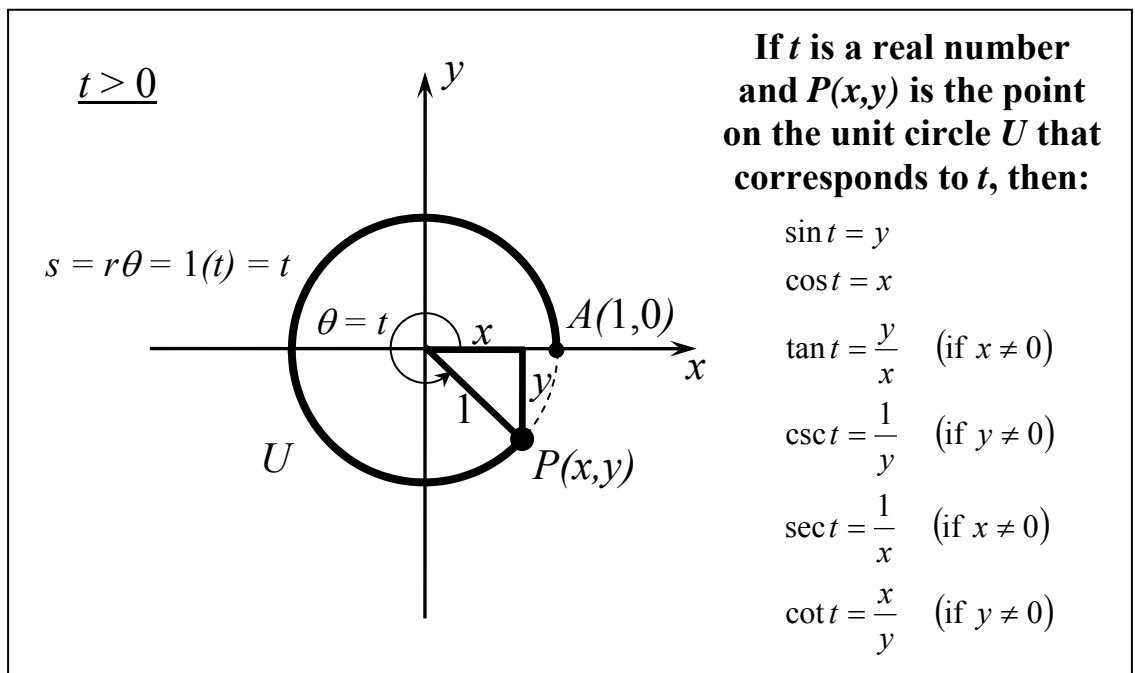

Figure 3.2 Student Knowledge at the Unit Circle Level

To think at the function level, students must be able to think at the geometric and unit circle levels as well as being able to successfully apply that knowledge to the function level. Thinking at the function level is being able to solve for elements such as amplitude, period, and phase shift when proceeding from a given function to a graph, e.g. see Figure 3.3 (adapted from Swokowski and Cole, 1999), or from a given graph to a function using either concrete numbers or variables.

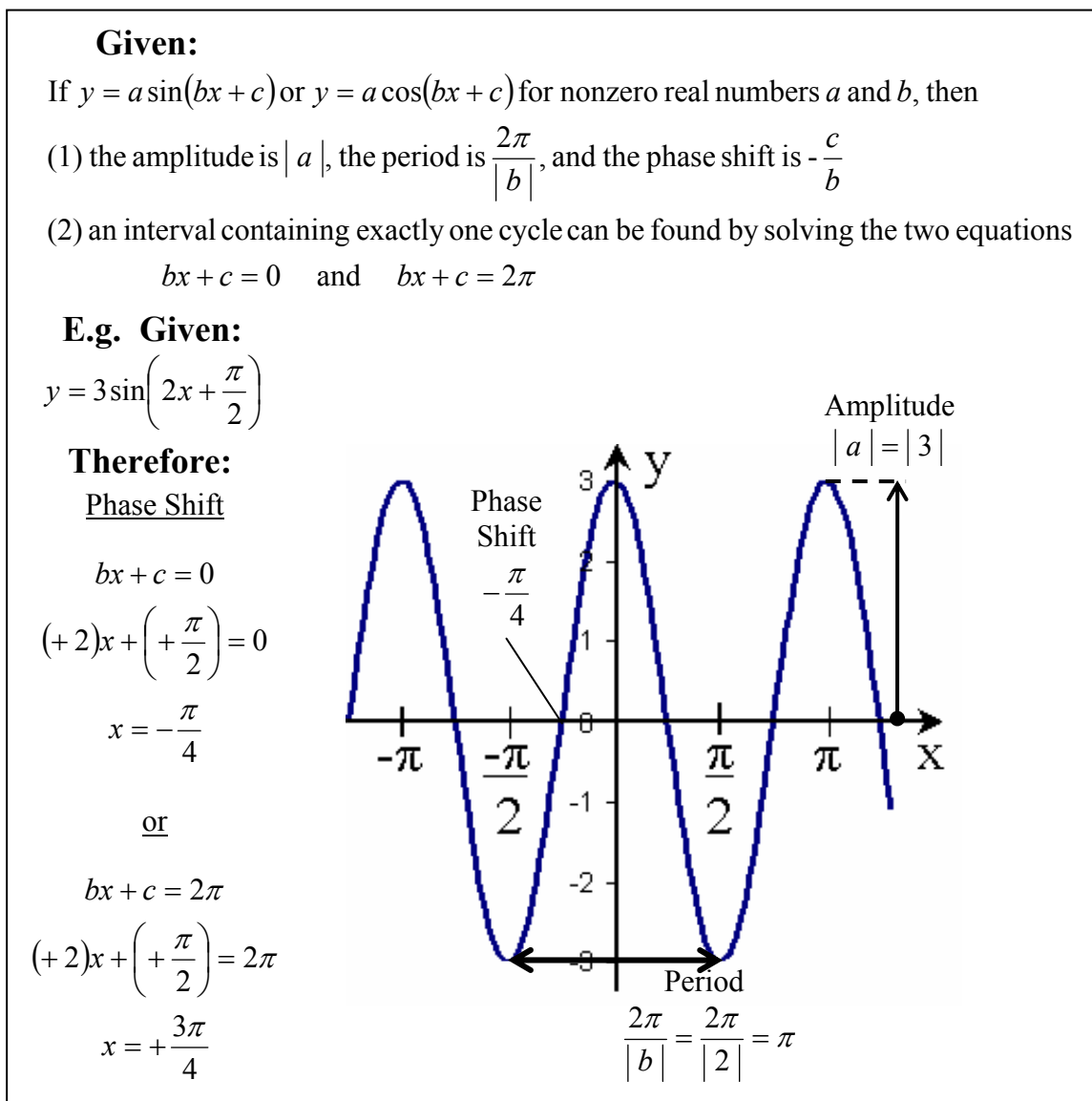

Figure 3.3 Student Knowledge at the Function Level

3.2.2. Survey Questions

The survey questions (see APPENDIX C) are designed to evaluate student retention and transfer of learning using the Van Hiele Levels (VHL's) for trigonometry. For each VHL, two types of survey questions were constructed—retention questions and transfer questions.

Survey questions to measure retention were designed to ask students to solve problems based on right triangles, unit circles, and functions (including graphs of functions). Retention questions were asked in an 'abstract' context, i.e. without any physics content, similar to questions in a trigonometry course.

The survey questions were also designed to assess transfer of learning from trigonometry to physics. In transfer questions, the trigonometric concept was embedded in a physical context. Our focus on transfer of learning dictated that our sample of students had previously taken *Trigonometry* at K-State and were enrolled in the algebra/trigonometry based *General Physics I* (GP1) course.

Surveys were constructed of questions generated by the author and from K-State's *Trigonometry* course textbook, Fundamentals of Trigonometry (Swokowski and Cole, 1999). We, "Author" in Table 3.1, generated questions in order to supplement the questions from the trigonometry textbook. The basic design of the survey consisted of sets of 'M'—mathematics (abstract) and 'P'—physics (contextual) questions (see Table 3.1). We generated questions similar to the questions used in the trigonometry textbook when similar questions were not available.

Question Number	Question Sets	Category	Van Hiele Level (VHL)	Source	
		M (Math)		S & C	
		P (Physics)		(Swokowski & Cole)	
1	(i)	M	I (geometric)	Author	
2		P		S & C	
3	(ii)	M		Author	
4		P		Author	
(5)	(iii)	M		Author	
(6)		P		S & C	
7	(iv)	M		II (unit circle)	S & C
8		P			S & C
9	(v)	M			Author
10		P			S & C (modified)
(11)	(vi)	M			Author
(12)		P			S & C (modified)
(13), (14), (15), 16	(vii)	M	III (function)		S & C (modified)
(17), (18), (19), 20		P			S & C (modified)
21, 22, 23, 24	(viii)	M			S & C (modified)
25, 26, 27, 28		P			S & C (modified)

Table 3.1 Pilot Survey Question Sets, Categories, Van Hiele Levels, and Sources

We administered the pilot survey (see APPENDIX C) to graduate students and post-doctoral research associates. We also discussed the survey with a faculty member of K-State’s Mathematics Department. Based on their input, 10 of the original 28 questions were eliminated from the pilot survey. The pre-instruction surveys (four survey versions – described below) were planned to be administered on the first day of recitation (see Section 3.2.3 for further details) which was prior to any physics instruction (i.e. lecture, recitation, and laboratory). The recitation instructor reserved time to take class role call and state some introductory comments prior to administering the survey. Due to time constraints of a 50 minute recitation (with instructor’s comments and class role call) and feedback from the pilot-tests, we believed the length of the number of questions on the pilot survey would be too great for the students to have adequate time to

complete during recitation. Based on a personal communication (Bennett, 2003), the questions eliminated from the pilot survey as a result of the pilot-tests and personal communication are in “parentheses” in Table 3.1 (questions 5–6,11–12,13–15, & 17–19).

The pre-instruction surveys (see APPENDIX D) administered on the first day of recitation consisted of 18 questions. The breakdown of question sets, categories, Van Hiele Level’s, and their source is shown in Table 3.2.

Question Number	Question Sets	Category	Van Hiele Level (VHL)	Source
		M (Math)		S & C
		P (Physics)		(Swokowski & Cole)
1	(i)	M	I (geometric)	Author
2		P		S & C
3	(ii)	M		Author
4		P		Author
5	(iii)	M	II (unit circle)	S & C
6		P		S & C
7	(iv)	M		S & C
8		P		S & C (modified)
9	(v)	M	III (function)	S & C (modified)
10		P		S & C (modified)
11 – 14	(vi)	M		S & C (modified)
15 – 18		P		S & C (modified)

Table 3.2 Pre-Instruction Survey (Version 1)
Question Sets, Categories, Van Hiele Levels, and Sources

Although the research goals of the project do not mention question order effects, the pre- and post-instruction surveys were designed to consist of four versions to determine whether order effects were present. Our decision to examine question order effects was prompted by recent research findings by Gray (2004).

All versions possessed identical questions. The order in which the questions appear on the survey was the only difference between survey versions (see Table 3.3).

All versions were consistent with the hierarchic arrangement of Van Hiele Levels (VHL) and began with questions of VHL–I (geometric level), followed by VHL–II (unit circle level), and then VHL–III (function level) questions.

Version	Question Order
V1	Math → Physics → Math ...
V2	Physics → Math → Physics ...
V3	All Math → All Physics
V4	All Physics → All Math

Table 3.3 Question Order of Pre- and Post-Instruction Survey Versions

Two post-instruction surveys (see APPENDICES E & F) were administered during laboratory which consisted of pre-instruction survey questions. Due to time constraints during laboratory, the pre-instruction survey was divided into two post-instruction surveys (see Table 3.4). The first post-instruction survey was composed of VHL–I and –II questions and the second was composed of VHL–III questions.

Pre-Instruction Survey Question Number	Post-Instruction Survey	Sets of Questions	Category	Van Hiele Level (VHL)	
			M (Math)		
			P (Physics)		
1	#1	(i)	M	I (geometric)	
2			P		
3		(ii)	M		
4			P		
5		#2	(iii)	M	II (unit circle)
6				P	
7			(iv)	M	
8				P	
9	#2	(v)	M	III (function)	
10			P		
11 – 14		(vi)	M		
15 – 18			P		

Table 3.4 Pre- and Post-Instruction Survey (Version 1) Question Sets, Categories, and Van Hiele Levels

3.2.3. Survey Demographics and Administration

The students who participated in the research were enrolled in an algebra-based physics course at K-State titled *General Physics I* (GP1) during the Fall 2003 semester. GP1 is the first part of a two semester series covering classical physics with a focus on mechanics. GP1 uses Giancoli's Physics textbook (1998) and is taken predominantly by life science, agriculture, and secondary education majors. To measure student retention and transfer from trigonometry to physics, the trigonometry sample (students who previously completed the *Trigonometry* course) will be analyzed (see Table 3.5).

Survey (All Versions)	Overall Sample (Number of Students)		Trigonometry Sample (Number of Trigonometry Students)		
Pre-Instruction	244	187	44		37
Post-Instruction #1	243		47	41	
Post-Instruction #2	220		46		

Table 3.5 Students Surveyed

The research study was designed to measure transfer of learning from trigonometry to physics; therefore, only demographic information (see APPENDIX A) of students who have completed K-State's *Trigonometry* course is provided in Table 3.6.

Female/Male Students	Average Age	Traditional Students	Average Year in College	Most Common Majors		Previous Physics Course
				Kinesiology	Biology	
53% / 47%	21.0	86%	2.9	43%	14%	61%

Table 3.6 Demographic Information of the Trigonometry Sample Surveyed

Students were asked to provide their gender, whether or not they considered themselves as a traditional student or returning adult, and their year in college. Students were also asked to provide their current major. Of all the trigonometry students surveyed, the two most frequent majors were kinesiology and biology. Another section on the Demographic Information Form (see APPENDIX A) asked students to indicate whether they have taken previous physics courses. A majority of the students responded that they have taken a high school physics course and some indicated they took a college level physics course. No effort was made to ask of the grade they received in the physics course(s) they provided.

The GP1 course instructor sent an email prior to all three surveys to inform all students of the surveys and a reminder to bring their calculators. Students were informed by their instructor that they would earn extra credit points toward their course grade based on their percentage of correct responses to the survey questions. The surveys were administered to *General Physics I* (GP1) students. All versions were printed on white paper. There were a total of six recitation sections. The first recitation section received version one, the second received version two, the third received version three, and the fourth received version four. Approximately half of the fifth recitation section received version one and the other half received version two; approximately half of the sixth recitation section received version three and the other half received version four.

The pre-instruction survey was distributed on the first day of recitation (August, 2003) following introductory comments and class roll call by the recitation instructor. The students had approximately 45 minutes to complete the survey. A brief description of the survey was given which included the person's name administering the survey,

topic of the research project, a description of the point allocation for extra-credit, and an explanation of choice “G” on the survey (see APPENDIX D.1). The description prior to beginning the survey also informed the students that once they completed the survey a form would be given to them to fill out (demographics section of APPENDIX A), return before they left the classroom, and that the form also included a section titled “Interview Requests.” The students were briefly informed of what the interviews would consist of and their participation for the interviews would result in a stipend of \$30 upon completion of all three interviews. The people administering the survey then informed the students that they could use calculators while taking the survey and then asked if they had any additional questions. A friendly concluding remark, “thank you for your time,” was then stated.

Students were asked to complete the Demographics and Interview Request Form (see APPENDIX A) after they completed the pre-instruction survey. Claude Steele (1997) proposes that a stereotype threat exists “when one is in a situation or doing something for which a negative stereotype about one’s group applies. The predicament threatens one with being negatively stereotyped, with being judged or treated stereotypically, or with the prospect of conforming to the stereotype” (Steele, 1997). Steele found that the stereotype threat could be invoked by asking students to record personal information before taking an exam, i.e. recording their race, which tended to lower their exam scores.

Two post-instruction surveys were distributed to the overall sample of GP1 students during the laboratory part of the course. Due to time constraints to allow students adequate time to complete the lab, the pre-instruction survey was administered

in two parts (see Table 3.4). The post–instruction surveys were distributed at the beginning of the laboratory prior to any introduction to the lab by the laboratory instructors. The students were politely asked to begin finishing the survey once 30 minutes have passed, but were not forced to complete the survey at a specific time.

Prior to administering the two post–instruction surveys, labels were constructed of each student enrolled in GP1. The labels included the student’s name, identification number, which laboratory section they were enrolled in, and which version of the pre–instruction survey they took to ensure all students received the same version of the pre– and post–instruction surveys. The post–instruction surveys were printed on colored paper (Version 1–Blue, Version 2–Green, Version 3–Pink, Version 4–Yellow) to help us distinguish between versions. Post–instruction survey #1 was distributed in October, 2003 after instruction and testing on kinematics, forces, and circular motion. Post–instruction survey #2 was distributed in December, 2003 after instruction and testing on harmonic motion.

3.2.4. Overall Survey Analysis

Validity and Reliability. The ultimate test of evidence is to determine whether or not the generalizations support the predictions. To have trustworthy evidence, the evidence must be relatively free from error (Tate, 1965); but error exists in most situations, therefore the goal is to minimize the error. Two methods of evaluating the trustworthiness of evidence are validity and reliability of the test. Validity is often defined as the degree to which a test measures what it is designed to measure. Reliability indicates how internally consistent a test measures what is measured. An example from a

target shooting perspective may be used to define the ideas of validity and reliability (Doran, 1980):

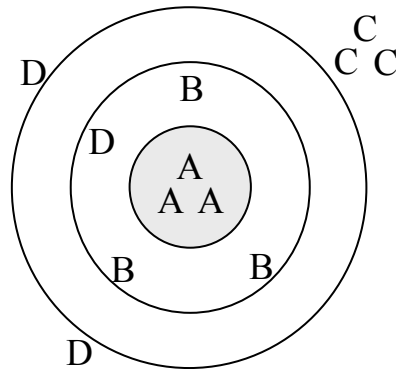

In “test jargon,” the marks in Group A are both valid and reliable; they are where they are supposed to be (the middle), and they are close together in a tight group. Group D is neither valid nor reliable since the marks are off center and widely separated. Group B is valid but unreliable, since the marks are around the bull’s-eye but are widely separated. Conversely, Group C is described as invalid but highly reliable in that the marks are way off center although tightly grouped. From this analogy, it is clear that test validity is more important than reliability, though both are valuable characteristics of good tests (p. 103).

The validity of the pre-instruction survey in this research study is that of *face validity*, or the appearance of validity (Krathwohl, 1998). Face validity was obtained by asking a mathematics professor and a physics professor about the trigonometry content of the entire survey. No effort was made to determine other types of validity of the survey.

The overall sample of *General Physics I* (GP1) students were used in analyzing reliability. Reliability of the pre- and post-instruction surveys is based on several measures. The Kuder-Richardson Formula 20 (KR-20) and Split-Half (RC) reliability techniques were used to measure the internal consistency of the test (survey). Both the KR-20 and Split-Half reliability statistics determine the homogeneity of the measure, i.e. that the test items measure one thing.

The KR–20 formula is defined as (Carey, 2001):

$$\text{KR} - 20 = \frac{n}{n-1} \left(1 - \frac{\sum p_i q_i}{\sigma^2} \right)$$

where

n = the total number of test items.

p_i = the proportion of students who answer each item correctly.

q_i = the proportion of students who answer each item incorrectly, or $1 - p_i$.

$p_i q_i$ = the proportion answering correctly times the proportion answering incorrectly. This value is called the *item variance*, and it is sometimes symbolized as s_i^2 .

Σ = sum the values for all test items.

σ^2 = the total test variance. This value is calculated as $\sum (X - \bar{X})^2 / N$.

When the group tested represents a sample rather than the population, this value will be written as s^2 and calculated using $N - 1$ in the denominator.

The Split–Half (RC) reliability measure uses the Spearman–Brown formula and the Pearson r to determine the internal consistency of the test (survey). The Pearson r , or the Pearson product–moment correlation coefficient, indicates the extent of the linear relationship between two variables. The range of values for r is from -1.00 to $+1.00$. The Spearman–Brown formula utilizes the Pearson r to result in the Split–Half formula (RC) which may be defined as:

$$\text{RC} = \frac{2r}{1+r}$$

where the Pearson r is defined as:

$$r = \frac{N \sum XY - (\sum X)(\sum Y)}{\sqrt{[N \sum X^2 - (\sum X)^2] [N \sum Y^2 - (\sum Y)^2]}}$$

where N is the total number of tests taken and X & Y are the dependent & independent variables. The Pearson r may be thought as the covariance in X and Y divided by the variability of X and Y separately.

KR-20 and Split-Half values typically range from 0.00 to 1.00, although negative values are possible. A value of 0.00 for these reliability measures reflects no internal consistency for the test. The minimum values of reliability are 0.70 for group measurement and 0.90 for individual measurement.

A reliability measure to determine the stability of the test over time is Test-Retest. Test-Retest is simply a calculation using the Pearson r (as described above) of pre-instruction survey scores and post-instruction survey scores. Test-Retest values are typically lower than KR-20 and Split-Half values. Scorer Reliability was not calculated due to the nature of the surveys consisting of multiple-choice questions.

Individual Test Items. The overall sample of *General Physics I* (GP1) students were used in analyzing individual test items. The first measure used to determine the quality of a test item is its difficulty for the group (Carey, 2001). The item difficulty index, p , is the proportion or percentage of students in the analysis group who answer the item correctly which is indicated by the following formula:

$$p = \frac{R}{N}$$

where R represents the number of students answering the item correctly and N is the total number of students taking the test. Since p is a proportion or a percentage, values of p range from 0.00 to 1.00 for a proportion or 0 to 100 if expressed as a percentage.

Therefore, the higher the p value, the easier the test item is for that group. The item difficulty index, p , values less than 0.50 (for a proportion) are interpreted as very difficult for that group (Carey, 2001).

Another statistical method used for individual test items is item discrimination index, d (Carey, 2001). The discrimination index, d , reflects the difference between the difficulty of a test item for the upper- and lower- scoring subgroups in a class.

$$d = p_u - p_l \quad \text{or} \quad \frac{R_u}{n_u} - \frac{R_l}{n_l}$$

where

p_u = the proportion in the upper subgroup who answers correctly

p_l = the proportion in the lower subgroup who answers correctly

R_u = the number in the upper subgroup who answers correctly

R_l = the number in the lower subgroup who answers correctly

n_u = the number of students in the upper subgroup

n_l = the number of students in the lower subgroup

Most often, the upper-scoring group is defined as the highest scoring 25 or 27 percent of the students taking the test and the lower-scoring group is defined as the lowest scoring 25 or 27 percent of the students taking the test. According to Carey (2001), the students who scored the highest on the overall test should score better than the students who earned the lowest scores on the test on an item-by-item basis. The discrimination indices range from -1.00 to $+1.00$. Table 3.7 (Carey, 2001) provides “rules of thumb” in interpreting the values obtained for the discrimination indices.

Quality Category	<i>d</i> value for <i>p</i> < 0.50	<i>d</i> value for <i>p</i> > 0.50
Unacceptable test item discrimination	Any negative value of <i>d</i>	Any negative value of <i>d</i>
No discrimination	$d \approx 0.00$	$d \approx 0.00$
Moderate discrimination	$d \approx \frac{1}{2} p$	$d \approx \frac{1}{2} q$
Good discrimination	$d \approx p$	$d \approx q$
Excellent discrimination	$d \approx 2p$	$d \approx 2q$

Table 3.7 Interpreting Discrimination Index Values

The final individual test item measurement used in this research study is that of the point-biserial correlation index (r_{pbi}) for discrimination.

$$r_{pbi} = \frac{\bar{X}_p - \bar{X}}{\sigma} \sqrt{\frac{p}{q}}$$

where

\bar{X}_p = the mean or average overall test score for only the subgroup of students who answers the item correctly

\bar{X} = the mean or average overall test score for the total class

σ = the standard deviation for the total test

p = the proportion of the total class who answers the item correctly

q = the proportion of the total class who answers the item incorrectly ($1 - p$)

This point biserial index indicates the extent to which an individual test item is a predictor of the overall test score. An item is judged consistent with students' overall test scores when students who earn the highest overall test scores answer the item correctly and students who earn the lowest overall scores answer incorrectly. The possible range for the point-biserial correlation index (r_{pbi}) for discrimination is from -1.00 to $+1.00$. Values for the point-biserial correlation index greater than or equal to 0.20 are ideal and indicates that the test items are reliable (Carey, 2001).

Question Order Effects. The overall sample of *General Physics 1* (GP1) students were used in analyzing question order effects. The surveys distributed consisted of four versions. All versions were composed of identical questions. The purpose of the four versions was to determine whether order effects were present in relation to the order in which questions were presented. The following formula was used for the “pooled” z -score of proportions to calculate the z -scores (Devore, 2004).

$$z = \frac{p_1 - p_2}{\sqrt{p(1-p) \left[\frac{1}{n_1} + \frac{1}{n_2} \right]}}$$

where

- p_1 = the proportion of students who answer each item correctly of one version
- p_2 = the proportion of students who answer each item correctly of the other version
- p = the proportion of students who answer each item correctly for both versions
- n_1 = the total number of students of one version
- n_2 = the total number of students of the other version

A z -score with a magnitude greater than or equal to 1.96 was considered to have a significant effect on the question order between the versions. Having $|z| \geq 1.96$ corresponds to a “ p ” value of less than 0.05, which means that for all results labeled statistically significant, there is less than a five percent likelihood the result quoted occurred because of random chance. To analyze question order effects, z -scores between all version combinations were calculated for each question on the pre- and post-instruction surveys.

3.3. INTERVIEW METHODOLOGY

3.3.1. Interview Protocol, Questions, and Supplementary Figures/Equations

The interviewer (the author) followed a pre-determined protocol, but when the interviewer felt it was necessary, additional questions were asked of the interviewees. Therefore, the interviews were semi-structured which are defined as: questions and order of presentation are pre-determined; questions have open-ends; interviewer records the essence of each response (Krathwohl, 1998). Examples of situations where the interviewer deviated from the protocol are to ask students to clarify an unclear response, to remind a student to explain their reasoning when solving problems or answering questions, etc. (see APPENDICES G, H, and I). Interviews were designed to gain a deeper understanding on retention and transfer of learning from trigonometry to physics.

The first three students (same throughout all three sets of interviews) participated in a pilot-test interview. The purpose of the pilot-test interviews was to gain feedback on the length of the protocol, questions, and supplementary figures. Questions that may have been asked during the pilot-test interviews that were not on the protocol were then included on the protocol for the remaining 10 interviews.

The structure of the interviews remained the same throughout all interviews. Students were given equation sheets (with the exception of the first three pilot-test interviews of the first round of interviews) during the interview that included relevant equations (determined by the interviewer) taken directly from class notes as well as from the *General Physics 1* (GP1) textbook. The students were provided equations from both sources in order to decrease confusion of symbols. After the first set of interviews,

equation sheets were provided before the interview began and the interviewees were asked to look at the equation sheet so that they could become familiar with the equations. The remainder of the interview was audio taped.

The next step that was consistent throughout all interviews was a brief description about the interview which included a statement of the physics concepts the interview is based on and a reminder of what the interviewees' role is, i.e. say thoughts and actions verbally, specify thoughts by pointing to the figure, write everything they possibly can without erasing. The interviewer also reminded the interviewees that he would be taking field notes throughout the interview and that he would be asking follow-up questions regardless of whether their responses were correct or incorrect.

The interviewees were then asked to read the first contextual question (i.e. something they would encounter in their GP1 course) and then to explain their reasoning. When students did not have any difficulty solving the question, the interviewer provided some supplemental abstract questions (i.e. something they would encounter in their trigonometry course) relevant to that particular contextual question. If the interviewees had difficulty in answering the question, the interviewer provided the students with a pre-determined set of supplemental abstract figures and questions in the hope that those questions would prompt the students to solve the contextual questions; thus, transfer their knowledge from trigonometry to physics. This method is typically known as "graduated prompting." Researchers (Newman et al., 1989; Campione and Brown, 1987) have used the graduated prompting strategy to assess the ease at which students are able to transfer their initial learning to a new situation. In the cases where the interviewees are not triggered by the supplemental abstract questions to solve the contextual question, it was

concluded that transfer of learning was not observed. In the cases where the student was able to solve the contextual question after s/he had solved the supplementary abstract question, it was concluded that successful transfer of learning had been observed between the abstract and contextual questions

3.3.2. Interview Demographics and Administration

Interviews were also used to supplement the survey data to acquire another view of student transfer from trigonometry to physics where a deeper understanding was needed than what is available with the surveys. Students who participated in the research were enrolled in an algebra-based physics course at Kansas State University (K-State) titled *General Physics 1* (GP1) during Fall 2003 semester and whom have already completed a *Trigonometry* course at K-State. In order to look at student retention and transfer from trigonometry to physics, students who have completed the *Trigonometry* course at K-State and who volunteered by signing the “Interview Request” form (see APPENDIX A) participated in the interviews.

A total of 13 students participated in all three interviews conducted during the semester. No attempt was made to ensure the participants were a representative sample of the population. The research study was designed to measure retention and transfer of knowledge from trigonometry to physics; therefore only demographic information (see APPENDIX A) of the students who have completed K-State’s *Trigonometry* course is provided in Table 3.8. Students were asked to provide the same information on the demographics form as discussed in Section 3.2.3.

Female/Male Students	Average Age	Traditional Students	Average Year in College	Major		Previous Physics Course
				Kinesiology	Biology	
46% / 54%	24.5	62 %	3.2	23 %	31 %	46 %

Table 3.8 Demographic Information of the Students Interviewed

For their participation, the students were compensated a stipend of \$30 upon completion of all three interviews. During the first day of recitation when the GP1 overall sample completed the pre-instruction survey, they were informed of the stipend. They were also explicitly told that at the end of each interview session, the interviewer would answer any questions they may have on the present or past content discussed in the GP1 course or on the interview material.

At the beginning of the first set of interviews, the students were asked to read consent forms. The consent form (see APPENDIX B) included pages from the Institutional Review Board (IRB) for research on human subjects and an addendum form specific to this research study. They were then asked if they had any questions. The interviewer also verbally explained the consent forms once the students were finished reading. The students were then asked to sign and date the consent forms which were copied and given to the participants. The author, interviewer, successfully completed an IRB training session for research involving human subjects through K-State.

A typical interview began with a brief conversation, i.e. usually questions like: How is everything going? How is the physics course? All interviews were audio taped for future reference. The audio cassette recorder was placed on the desk and was not concealed in any manner and students had additional paper accessible to them to write on if they ran out of room on the question or figure sheets provided. A typical interview

lasted 45 minutes with an additional 15+ minutes of any questions they may have on the interview material or GP1 course content. Some interviews lasted up to 60 minutes and others were as short as 35 minutes. The only people present during the interviews were the interviewer and the students.

3.3.3. Analysis of Interview Data

The interviewer took field notes during the interviews. Students were given an adequate amount of space and encouraged to write on all question, equation, and figure sheets of paper provided. The interview protocol (field notes), question, equation, and figures were used to analyze the interview data. At certain times during the interviews, the interviewer may not have had time to write the students' comments. During these situations the interviewer referred back to those points during the interview on the audio tapes and made additional notes.

Student comments on various protocol or additional questions the interviewer thought of during the interview were divided into categories based on the response and analyzed. For each category, emergent themes were grouped and then compared by groups. All of the mentioned interview analysis techniques enabled us to gain useful insights and a deeper understanding of student retention and transfer of learning from trigonometry to physics. Also, we will gain insight as to which prompting questions trigger students to use their initial knowledge and successfully apply that knowledge to the transfer situation.

3.4. ADDRESSING THE RESEARCH QUESTIONS

Additional data were obtained to help answer the research questions. The additional data includes student maximum scores from on-line trigonometry homework assignments as well as their number of attempts on each assignment. The on-line trigonometry homework assignments were categorized by Van Hiele Levels (VHL's) for trigonometry. After discussion with a trigonometry professor, a better measure of student learning on each on-line homework assignment is calculated by taking the maximum score the student earned on each homework assignment divided by the number of attempts. The reason for this calculation is because students were given as many attempts as needed to complete the assignments, they could also print the assignments, and they could reference any resource available to them (students could complete the assignments at home). According to the trigonometry professor, from looking at previous data, students did not typically repeat assignments once they obtained a relatively high score on the assignment (i.e. greater than 90 percent) and some take many attempts to completing the assignments. Therefore, in all calculations involving the on-line trigonometry assignments, the maximum score divided by the number of attempts was used. Student grades from their *Trigonometry* course were also obtained as well as *General Physics 1* (GP1) final exam and course percentage grades. In all data used in the results for each research question, the trigonometry sample of students was used (students who have completed K-State's *Trigonometry* course).

Research Question # 1: What concepts have the students learned in the trigonometry courses?

To answer this research question, we examined data from the on-line trigonometry homework assignments and trigonometry course grades (see Figure 1.1). A correlation between student average maximum scores divided by the number of attempts for all on-line homework assignments and course grades was calculated. For this correlation to measure learning in trigonometry, the calculation included students who have completed the course with a grade of D or higher (i.e. > 60%).

Student maximum scores divided by the number of attempts for each homework assignment were then averaged for each VHL for trigonometry. A t -test was used to determine whether the differences in student learning for the VHL's are statistically significant. The formula for the t -test is (Howell, 1999):

$$t = \frac{(\bar{X}_1 - \bar{X}_2) - (\mu_1 - \mu_2)}{\sqrt{\frac{\sigma_1^2}{n_1} + \frac{\sigma_2^2}{n_2}}}$$

where \bar{X}_1 & \bar{X}_2 are the means of the first and second group of scores respectively, μ_1 & μ_2 are the population means for each group of scores, σ_1 & σ_2 are the standard deviations for each group of scores, and n_1 & n_2 are the numbers of scores in each group. For the t -test calculation, we used $\mu_1 = \mu_2$ because this is a test of the null hypothesis ($\mu_1 - \mu_2 = 0$) involving the difference between independent sample means. For each group of scores, the degrees of freedom (df) was greater than 120 and as the degrees of freedom increase, the critical value at which the t -test is statistically significant

decreases. Therefore, a t -value greater than or equal to 3.373 for 120 degrees of freedom (df) is considered statistically significant at the 0.001 level (alpha level).

Additional data were requested of student final exam grades for each question on the final exam which would be classified to specific VHL's for trigonometry to measure the specific concepts the students learned in their trigonometry course. Due to time constraints, the final exam data were not obtained and therefore limits the amount of justification we can claim for Research Question #1. The final exam data will eventually be obtained and used for further analysis in measuring student learning in trigonometry.

Research Question # 2: What knowledge do the students retain from their trigonometry course when they begin their physics course?

To answer this research question, several analysis procedures were implemented. The proportion of students who had taken *Trigonometry* previously at K-State that correctly answered questions in each of the Van Hiele Levels (VHL's) for trigonometry on the pre-instruction survey was calculated. A correlation between student average maximum scores divided by the number of attempts for all on-line homework assignments and their pre-instruction survey mathematics (abstract) questions scores was calculated. The on-line homework assignments were also categorized into VHL's and correlated with the pre-instruction survey mathematics (abstract) questions pertaining to corresponding VHL's. Finally, a correlation between student pre-instruction survey mathematics (abstract) question scores and their course grades was calculated. For this correlation to measure retention of learning in trigonometry, the calculation included students who have completed the course with a grade of D or higher (i.e. > 60%).

Research Question # 3: How consistently do students use their understanding developed in trigonometry courses when encountering these ideas in new contexts?

This research question was addressed in several parts. First, a traditional perspective of transfer was used to assess transfer of learning from trigonometry to physics. Next, transfer of learning was examined from the preparation of future learning (PFL) perspective (Bransford and Schwartz, 1999) and finally from the actor-oriented transfer perspective (Lobato, 2003).

Traditional Perspective. Traditional models (e.g. Reed, 1993; Singley and Anderson, 1989) focus on whether or not students are able to transfer a pre-defined concept which researchers hope they would transfer. The researchers look for evidence that the students have been able to transfer the pre-defined concept from a context in which the concept was initially learned to a different context. In the traditional models of transfer, transfer is a passive, static process. To analyze transfer from the traditional perspectives, several methods were implemented.

First, the relevant (first six) on-line trigonometry assignments average maximum score divided by the number of attempts were correlated with the pre- and post-instruction survey total physics (contextual) question scores. To obtain a deeper understanding of what knowledge the students transfer, each on-line trigonometry assignment was correlated with the total physics (contextual) question scores on both pre- and post-instruction surveys. Finally, to probe even deeper into transfer of learning from the traditional perspective, the on-line assignments were categorized into the VHL they corresponded to and then correlated with the students' total physics (contextual)

question score of the same VHL's for both surveys. Also, the trigonometry course grades were correlated with the overall pre- and post-instruction survey physics (contextual) questions. To further assess the specific knowledge student's transfer from trigonometry to physics, the trigonometry course grades were correlated with the VHL physics (contextual) questions on the pre- and post-instruction surveys.

All correlation calculations were examined as to whether or not the correlation was significant by looking in a table of critical values for various alpha significance levels (see Bruning and Kintz, 1997). To determine the significance of the correlation coefficient r , a z -test (for $n > 30$) or a t -test (for $n < 30$) was calculated. The z -test was calculated by using the following formula:

$$z = r\sqrt{n - 1}$$

where r is the correlation coefficient and n is the number of pairs of scores. Values of z that are considered to be statistically significant at the 0.05 significance (alpha) level are: $|z| \geq 1.96$. The t -test was calculated according to the following formula:

$$t = r\sqrt{(n - 2)(1 - r^2)}$$

where $(n - 2)$ is the degrees of freedom (df) and r is the correlation coefficient. Values of t that are considered to be statistically significant are determined by the critical values of a t -statistic in standard tables (see Bruning and Kintz, 1997).

Preparation for Future Learning Perspective. Bransford and Schwartz (1999) provide a contemporary perspective of transfer called "preparation for future learning" (PFL). The focus is on whether the initial learning helps students *learn* to solve problems in the

new situations with the opportunity to utilize resources (i.e. texts, colleagues, feedback) they may have had available during the initial learning situation.

Since students taking our surveys were not permitted to use resources, a way to measure transfer from the PFL perspective is by looking at each students' gain in scores on the physics (contextual) survey questions. These gain scores serve as a measure of *learning* that occurs during the physics course. The gain on the physics (contextual) questions was correlated with the on-line trigonometry homework assignments and the pre-instruction survey mathematics (abstract) question scores. To obtain a deeper insight into transfer of learning from the PFL perspective, the on-line trigonometry homework assignments and the pre-instruction survey mathematics (abstract) questions were also categorized into the respective VHL's. Another albeit cruder method to analyze transfer from the PFL perspectives is a correlation between the *Trigonometry* course grades and the *General Physics 1* (GP1) grades with the assumption that the GP1 course grades are a measure of learning in the course. Another aspect of the PFL perspective is the types of questions students generate as they attempt to solve a problem. Thus, the interview data were analyzed to determine whether or not the protocol questions prompt students to transfer their learning by helping them generate relevant questions.

Actor-Oriented Transfer Perspective. Lobato (2003) conceives transfer as the *personal construction of similarities between activities*. She examines transfer by looking at the nature of situations and the similarities people construct across the situations. Evidence for transfer is gathered by scrutinizing a given activity for any indication of influence from previous activities (Lobato, 2003). Therefore, to examine

transfer of learning from the actor-oriented perspective, several methods of analysis were possible. The first analysis of transfer is by correlating the pre-instruction survey mathematics (abstract) questions with the pre-instruction survey physics (contextual) questions and between the post-instruction survey mathematics questions and post-instruction survey physics questions to determine whether or not dynamic transfer is occurring in the survey itself. Another method of looking at transfer from the actor-oriented perspective is through a correlation between the pre- and post-instruction survey gains on the mathematics and physics questions. Yet another measure of actor-oriented transfer is whether students' refer to their solution of an abstract trigonometry problem in the interview as they work through the corresponding physics problem.

CHAPTER 4

RESULTS AND DISCUSSION

4.1. SURVEYS

The results and discussion of the survey analysis is divided into five sections. The first section (4.1.1) looks at the overall results of the surveys and focuses on measures of central tendency and measures of dispersion/variability. The next section (4.1.2) provides results of the overall reliability of all survey versions combined for both the pre- and post-instruction surveys. The third section (4.1.3) includes results of an analysis of each individual test item for difficulty, discrimination, and reliability. The fourth section (4.1.4) provides a brief look at results from the effect on the order of questions for all survey version combinations for both the pre- and post-instruction surveys. The final section (4.1.5) looks at the results of the research questions through the quantitative (survey) analysis.

4.1.1. Overall Results

The overall score distribution of the raw scores on the pre-instruction survey is shown in Figure 4.1. The pre-instruction survey is positively skewed, i.e. there is an imbalance toward lower scores in the distribution. The positive skew may be indicative of a test that is too difficult for low achieving students causing the graph to bunch up at the very low scores – a “floor” effect, but it will spread out the high achieving students (Krathwohl, 1998). Therefore, the pre-instruction survey may be interpreted as a difficult test. With

a skewed distribution, we are more likely to use the median or mode rather than the mean to represent the data's central tendency.

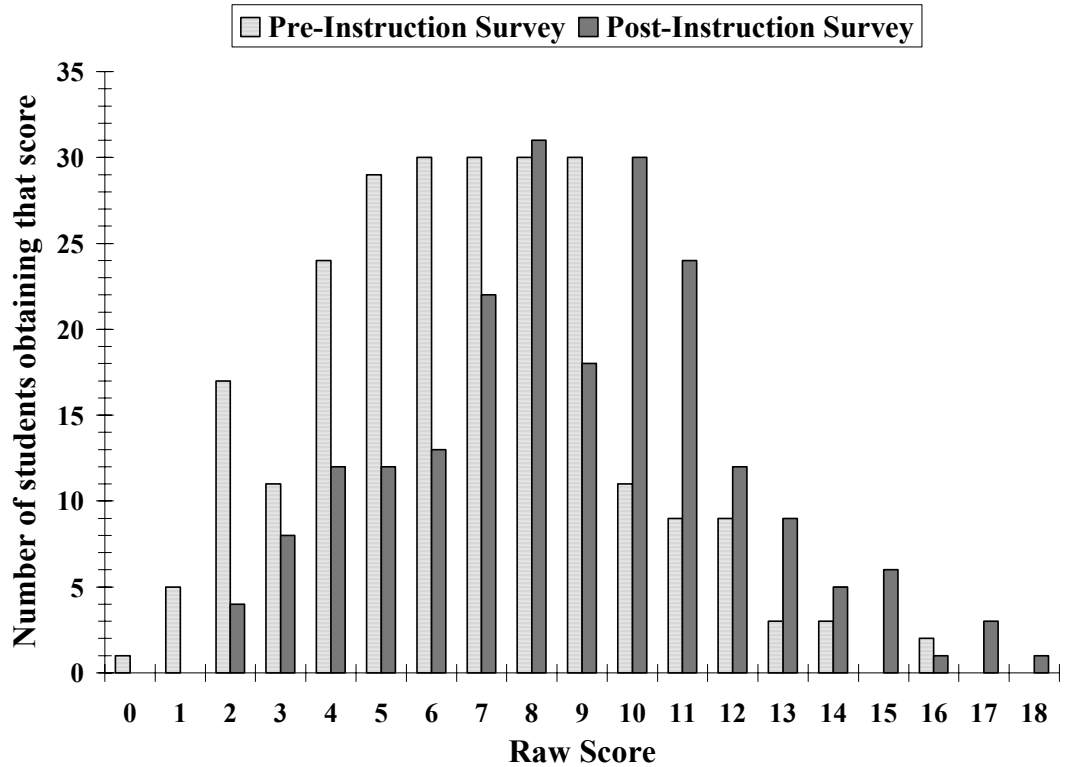

Figure 4.1 Pre- and Post-Instruction Survey Score Distribution of Overall Sample

The post-instruction survey (see Figure 4.1) is slightly skewed, but is for the most part symmetrical except for the low number of students who obtained a raw score of 9 (nine) points – the distribution is multimodal. Therefore, the mean, median, or mode may be used to represent the data's central tendency of the post-instruction survey. It may be interpreted as a test that is not too difficult for low achieving students and not too difficult for high achieving students, i.e. the spread of scores is distributed symmetrically and therefore the test discriminates well for low and high achieving students.

Measures of central tendency for the mode and median for each version (V#) of the pre- and post-instruction surveys are provided in Table 4.1.

Measure	Pre-Instruction Survey					Post-Instruction Survey				
	V1	V2	V3	V4	All V's	V1	V2	V3	V4	All V's
n	55	65	63	61	244	55	53	48	55	211
Mode	9	7	5	8	6	10	8	8	10	8
Median	7	7	6	7	7	10	9	8	9	9

Table 4.1 Overall Survey Results

The mean (arithmetic average) and the standard deviations for each version (V#) of both surveys are provided in Table 4.2.

Version	Pre-Instruction Survey	Post-Instruction Survey
V1	7.1 ± 3.2	9.2 ± 3.3
V2	6.8 ± 2.7	8.8 ± 3.5
V3	6.2 ± 3.3	8.0 ± 3.3
V4	6.9 ± 2.9	8.9 ± 3.0
All V's	6.7 ± 3.0	8.8 ± 3.3

Table 4.2 Overall Mean Survey Results

Figure 4.2 compares the pre- and post-instruction survey mean scores for all versions along with their standard deviations (error bars). This figure indicates that all versions may be used interchangeably because all version standard deviations from the mean score fit within approximately the same range for both surveys. Version 3 consisted of all mathematics (abstract) questions followed by all physics (contextual) questions, which has the lowest average scores for both pre- and post-instruction surveys. According to Figure 4.2, the students improved overall on each survey (all versions) after physics instruction on the relevant survey concepts.

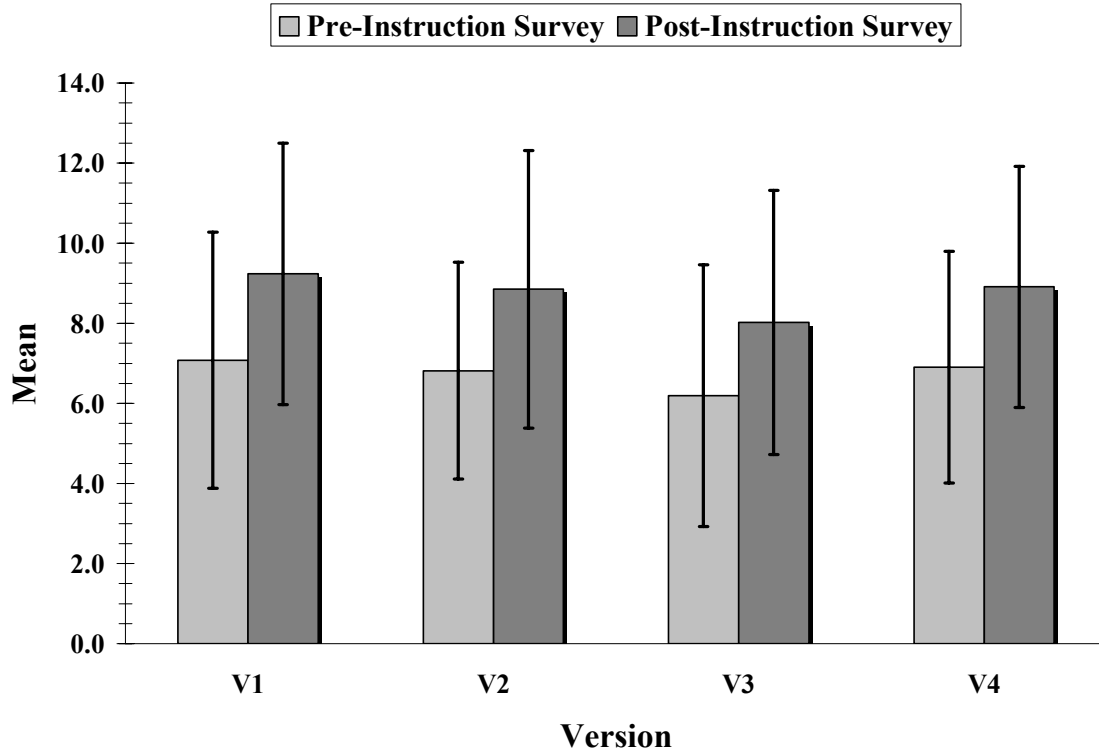

Figure 4.2 Pre- and Post-Instruction Survey Mean Scores per Version

An analysis of variance (ANOVA) was also calculated using Microsoft Excel 2002 of the overall total survey scores for all versions and all surveys to determine whether or not there is a statistical difference between versions (see Tables below).

Source of Variation	<i>SS</i>	<i>df</i>	<i>MS</i>	<i>F</i>	<i>P-value</i>	<i>F critical</i>
Between Versions	27.07	3	9.02	0.99	0.40	2.64
Within Versions	2182.62	240	9.09			
Total	2209.69	243				

Table 4.3 Pre-Instruction Survey ANOVA Summary for Survey Versions

Source of Variation	<i>SS</i>	<i>df</i>	<i>MS</i>	<i>F</i>	<i>P-value</i>	<i>F critical</i>
Between Versions	9.03	3	3.01	0.88	0.45	2.64
Within Versions	816.04	239	3.41			
Total	825.07	242				

Table 4.4 Post-Instruction #1 Survey ANOVA Summary for Survey Versions

Source of Variation	<i>SS</i>	<i>df</i>	<i>MS</i>	<i>F</i>	<i>P-value</i>	<i>F critical</i>
Between Versions	17.38	3	5.79	1.34	0.26	2.65
Within Versions	932.30	216	4.32			
Total	949.69	219				

Table 4.5 Post-Instruction #2 Survey ANOVA Summary for Survey Versions

According to Tables 4.3 – 4.5, there is no statistically significant difference between versions on neither the pre- nor post-instruction surveys. Therefore, the surveys may be used interchangeably to assess student retention and transfer. However, statistically significant differences in student performance on individual questions between the versions exist, and these will be discussed later in the chapter (Section 4.1.4).

4.1.2. Reliability

Reliability is a measure of the homogeneity that the content of the items on the survey is similar to each other, i.e. all the test items measure the same thing. The higher the value of the reliability index, the more homogeneous the test is which means that it is made up of items that measure the same thing. The lower the value, the test is not measuring the same thing and therefore is not as homogeneous as it claims. Several methods of calculating the reliability (KR-20 and Split-Half), or the internal consistency were used. An additional method of calculating the stability of the test (Test-Retest) was also used to determine if the behavior was stable over time because we had pre- and post-instruction surveys. The reliability indices for these methods are indicated in Table 4.6.

Survey	Kuder–Richardson Index (KR–20)	Split–Half (RC)	Test–Retest (n = 187)
Pre–Instruction (n = 244)	0.62	0.71	0.52
Post–Instruction (n = 211)	0.70	0.72	
Ideal Value	≥ 0.70 for group measurement		0.32 (α = 0.001)

Table 4.6 Survey Reliability

Are all the survey items measuring the same thing? To answer this question, the KR–20 formula was used. The KR–20 error variance is in content sampling and content heterogeneity. It is a measure of the internal consistency of the instrument. The purpose is to compare the item variance with the total test variance to determine the homogeneity of the instrument and the interpretability of the scores. This index value is affected by group heterogeneity, content homogeneity, test length, and item difficulty. Values of KR–20 that are less than 0.50 are questionable according to Carey (2001).

The Split–Half error variance is in content sampling. It is a measure of the internal consistency of the instrument. For our purpose, instead of using a random Split–Half method because the survey was designed to consist of an equal and equivalent number of mathematics (abstract) and physics (contextual) questions, the split of the test items was between the mathematics and physics questions.

The minimum desirable value for the KR–20 and Split–Halves reliability is 0.70 for group measurements. For the most part, the values calculated in Table 4.6 indicate the surveys are reliable and can be used for group measurements. The low KR–20 value for the pre–instruction survey may raise some questions about the reliability; but when calculating the reliability of each individual test item using the point–biserial correlation

coefficient (Section 4.1.3), all pre-instruction survey items are reliable. Based on this result and the reliability values for the Split-Half measure, the surveys are considered to be reliable.

Is the student behavior while taking the survey stable over time? In order to answer this question, the Test-Retest reliability measure was used. The Test-Retest error variance is a measure of the stability of the test over time. The Pearson correlation between pre- and post-instruction survey scores was used to determine the Test-Retest reliability. For $n = 187$, a Pearson correlation coefficient of 0.52 establishes Test-Retest reliability at a greater than 0.001 significance level.

Since it is clear that a number of factors, i.e. test length and item difficulty, affect the reliability of the instrument, a solution to increase the reliability is to lengthen the test. One way to increase the reliability is to lengthen the test as per the formula below to achieve the desired Split-Half reliability:

$$RC_{\text{new}} = \frac{n(RC_{\text{old}})}{1 + (n - 1)RC_{\text{old}}}$$

where RC_{new} is the Split-Half reliability index you wish to obtain with a new test, RC_{old} is the Split-Half reliability index you calculated from the original test, and n is how much the test was lengthened or shortened. Using the Split-Half value (0.71) for the pre-instruction survey (18 questions); the test-lengthening formula yields a new reliability value of 0.79 if the original survey (28 questions) was used. But due to time constraints in administering a survey on the first day of recitation, we needed to use a shorter instrument (pre-instruction survey) which in turn, possibly lowered the reliability.

Another way to increase the reliability is to remove questions that have a lower discrimination index. The average discrimination index for the pre- and post-instruction surveys respectively, was 0.41 and 0.44. Further discussion is included in the next section about this issue. The variability in the number of alternatives the students were able to choose from also affects the discrimination index which in turn affects reliability. But this rival explanation was eliminated in the design of the survey by having the same number of alternatives for each question.

4.1.3. Individual Test Items

Table 4.7 shows the results of the individual test items for the pre- and post-instruction surveys. The shaded and bolded cells under the “Proportion of Responses that Selected Choice” column indicate the proportion of correct responses for each question. Questions 1 through 18 are grouped in sets (i) through (vi) as per Van Hiele Level (VHL). There are two sets of questions corresponding to each VHL I through III. Each question set consists of two isomorphic questions categorized as ‘M’ for the abstract math question or ‘P’ for the contextual physics question. Both the ‘M’ and ‘P’ questions in each set address the same underlying trigonometric concept. However, the ‘M’ question requires no knowledge of physics, where as the ‘P’ questions assess the trigonometric concept in a physics context that is relevant to the content of the *General Physics I* (GP1) course.

The question numbers in all tables within this section are for version 1 of the pre-instruction survey (see APPENDIX D.1).

Question #	Question Sets	Category	Van Hiele Level	Proportion of Responses that Selected Choice														Point-Biserial Correlation ($r_{pb i}$)		Discrimination (d)		Difficulty (p)	
				A		B		C		D		E		F		G							
				Pre	Post	Pre	Post	Pre	Post	Pre	Post	Pre	Post	Pre	Post	Pre	Post	Pre	Post	Pre	Post	Pre	Post
1	i	M	I	0.03	0.00	0.06	0.06	0.66	0.86	0.14	0.05	0.03	0.01	0.03	0.00	0.04	0.02	0.57	0.47	0.71	0.39	0.66	0.86
2		P		0.18	0.17	0.56	0.67	0.13	0.07	0.02	0.01	0.03	0.02	0.01	0.02	0.06	0.03	0.41	0.38	0.48	0.39	0.56	0.67
3	ii	M		0.52	0.78	0.12	0.06	0.15	0.09	0.03	0.01	0.10	0.02	0.03	0.02	0.04	0.01	0.56	0.43	0.68	0.46	0.52	0.78
4		P		0.08	0.10	0.20	0.07	0.51	0.70	0.04	0.04	0.08	0.03	0.04	0.01	0.04	0.06	0.47	0.46	0.62	0.58	0.51	0.70
5	iii	M	II	0.13	0.07	0.06	0.03	0.24	0.20	0.27	0.38	0.18	0.20	0.02	0.01	0.06	0.09	0.30	0.48	0.35	0.60	0.27	0.38
6		P		0.05	0.05	0.03	0.00	0.07	0.06	0.20	0.17	0.50	0.59	0.03	0.04	0.08	0.09	0.22	0.38	0.30	0.53	0.50	0.59
7	iv	M		0.27	0.31	0.22	0.26	0.09	0.08	0.25	0.16	0.03	0.06	0.04	0.05	0.05	0.06	0.26	0.42	0.23	0.49	0.27	0.31
8		P		0.08	0.09	0.14	0.08	0.17	0.08	0.29	0.40	0.16	0.17	0.06	0.11	0.06	0.05	0.23	0.29	0.21	0.37	0.29	0.40
9	v	M	III	0.04	0.03	0.07	0.03	0.46	0.63	0.22	0.20	0.12	0.05	0.05	0.05	0.01	0.01	0.42	0.46	0.53	0.53	0.46	0.63
10		P		0.10	0.07	0.11	0.14	0.30	0.26	0.22	0.38	0.16	0.09	0.06	0.05	0.01	0.01	0.20	0.17	0.18	0.23	0.22	0.38
11	vi	M		0.08	0.05	0.09	0.01	0.07	0.05	0.16	0.05	0.08	0.07	0.48	0.76	0.02	0.00	0.46	0.52	0.58	0.58	0.48	0.76
12				0.27	0.39	0.28	0.16	0.22	0.25	0.07	0.04	0.07	0.07	0.03	0.04	0.04	0.03	0.37	0.52	0.30	0.56	0.22	0.25
13			0.07	0.04	0.08	0.07	0.23	0.29	0.14	0.07	0.17	0.14	0.14	0.19	0.13	0.19	0.33	0.31	0.36	0.21	0.23	0.29	
14		P	0.20	0.33	0.43	0.36	0.13	0.14	0.06	0.03	0.07	0.05	0.05	0.04	0.05	0.06	0.33	0.36	0.41	0.42	0.43	0.36	
15			0.09	0.08	0.11	0.04	0.09	0.06	0.21	0.12	0.04	0.00	0.44	0.70	0.02	0.00	0.55	0.50	0.71	0.58	0.44	0.70	
16			0.10	0.06	0.11	0.07	0.13	0.10	0.47	0.51	0.09	0.15	0.08	0.07	0.01	0.02	0.23	0.50	0.11	0.37	0.09	0.15	
17	0.11	0.07	0.18	0.11	0.12	0.15	0.13	0.13	0.34	0.47	0.09	0.04	0.01	0.02	0.21	0.38	0.09	0.19	0.11	0.07			
18	0.07	0.07	0.30	0.29	0.48	0.48	0.07	0.02	0.02	0.02	0.03	0.05	0.03	0.06	0.36	0.41	0.45	0.47	0.48	0.48			
Average:																	0.36	0.41	0.37	0.41	0.44	0.49	

Table 4.7 Individual Test Item Results of Pre- and Post-Instruction Surveys

Item Difficulty Index, p . The item difficulty index refers to the proportion of students who answer the item correctly. The typical minimum accepted value for the item difficulty index (p) is 0.50. Items with difficulty index values less than 0.50 are considered to be very difficult.

Questions 16 and 17 (see APPENDIX D.1) were the most difficult for students on both the pre- and post-instruction surveys, while Questions 1 through 4 were the easiest. Questions 16 and 17 were VHL-III questions that asked students to calculate the period and the phase shift of a given function in a physics context, while Questions 1 through 4 were all VHL-I questions. This result is consistent with the idea of progressive difficulty of advancing VHL's. Moreover, Questions 16 and 17 require students to apply the trigonometric concepts in the context of a physics problem, therefore students score even lower on these questions than the corresponding mathematics questions (12 and 13). This result indicates that a larger proportion of students are able to solve abstract mathematics questions in VHL-III better than corresponding questions in a physics context.

According to Table 4.8, which shows the difficulty index difference between pre- and post-instruction surveys, all test items yield positive differences which reflect good technical characteristics except for items 14 & 17. The items that have small or no differences (7, 12, 13, 16, & 18) or negative differences (14 & 17) supposedly reflect technical problems with the item, the instruction, or both (Carey, 2001). We discuss issues with each of these questions separately.

Question 7 is one of four questions that require students to solve a VHL-II (unit circle) problem. Question 7 is a mathematics (abstract) problem that may result in

difficulty for many students as the unit circle was not discussed extensively during physics instruction (GP1).

Question Number	Question Sets	Category	Van Hiele Level (VHL)	Difficulty (p)			
				Pre – Instruction	Post– Instruction	Difference	
1	(i)	M	I	0.66	0.86	0.20	
2		P		0.56	0.67	0.11	
3	(ii)	M		0.52	0.78	0.26	
4		P		0.51	0.70	0.19	
5	(iii)	M		II	0.27	0.38	0.11
6		P			0.50	0.59	0.09
7	(iv)	M	0.27		0.31	0.04	
8		P	0.29		0.40	0.11	
9	(v)	M	III		0.46	0.63	0.17
10		P			0.22	0.38	0.16
11	(vi)	M			0.48	0.76	0.28
12					0.22	0.25	0.03
13				0.23	0.29	0.06	
14				0.43	0.36	-0.07	
15		P		0.44	0.70	0.26	
16				0.09	0.15	0.06	
17				0.11	0.07	-0.04	
18				0.48	0.48	0.00	

Table 4.8 Item Difficulty Index Differences

Questions 12, 13, 14, 16, 17, & 18 all involve students to think at the highest VHL for trigonometry which causes difficulty for some students, possibly due to the lack of instruction on these particular concepts. These questions ask students to solve for the period, phase shift, and to determine the graph of a given function. An interesting point to note, questions 11–18 all involve students to think at VHL–III, but questions 11 & 15 (the only other two questions) both yielded the highest pre– vs. post–instruction gains.

Therefore, it appears that physics instruction does enhance students' understanding in specific aspects of VHL–III such as determining the amplitude of a function.

Item Discrimination Index, d . The discrimination index is used to judge the quality of a test item. This comparison is shown in Table 4.9. The q value is the proportion of students who answered the item incorrectly, $q = 1 - p$, and is used along with p to evaluate the discrimination index. The discrimination index (d) reflects the difference between the difficulty of a test item for the upper- and lower- scoring subgroups in a class. The upper-scoring subgroup was defined as the highest scoring 27 percent of the students in the class and the lower-scoring subgroup was defined as the lowest scoring 27 percent. The higher the discrimination index, the better the item separates the students who scored well overall on the test and those who did not (Carey, 2001).

Based on the data in Table 4.9 and the criteria for quality categories in Table 3.7, (Interpreting Discrimination Index Values), there are no test items that are unacceptable or items that have no discrimination. A majority of the test items have good or excellent discrimination. Therefore, overall, the surveys have good discrimination and may be considered as a high-quality test; that is to say the surveys can be used to measure retention and transfer from trigonometry to physics.

Question Number	Question Sets	Category	Van Hiele Level (VHL)	Pre -Instruction					Post-Instruction					
				<i>p</i>	<i>q</i>	<i>d</i>	<i>d/p</i> or <i>d/q</i>	Quality Category	<i>p</i>	<i>q</i>	<i>d</i>	<i>d/p</i> or <i>d/q</i>	Quality Category	
1	(i)	M	I	0.66	0.34	0.71	2.09	Good /Moderate	Excel lent	0.86	0.14	0.39	2.79	Excel lent
2		P		0.56	0.44	0.48	1.09		0.67	0.33	0.39	1.18	Good	
3	(ii)	M		0.52	0.48	0.68	1.42		0.78	0.22	0.46	2.09	Excel lent	
4		P		0.51	0.49	0.62	1.27		0.70	0.30	0.58	1.93		
5	(iii)	M	II	0.27	0.73	0.35	1.30		0.38	0.62	0.60	1.58	Good	
6		P		0.50	0.50	0.30	0.60		0.59	0.41	0.53	1.29		
7	(iv)	M		0.27	0.73	0.23	0.85		0.31	0.69	0.49	1.58		
8		P		0.29	0.71	0.21	0.72		0.40	0.60	0.37	0.93		
9	(v)	M	III	0.46	0.54	0.53	1.15		0.63	0.37	0.53	1.43	Moderate	
10		P		0.22	0.78	0.18	0.82		0.38	0.62	0.23	0.61		
11	(vi)	M		0.48	0.52	0.58	1.21		0.76	0.24	0.58	2.42		Excel lent
12				0.22	0.78	0.30	1.36		0.25	0.75	0.56	2.24		
13			0.23	0.77	0.36	1.57	0.29		0.71	0.21	0.72	Moderate		
14			0.43	0.57	0.41	0.95	0.36		0.64	0.42	1.17	Good		
15		P	0.44	0.56	0.71	1.61	0.70		0.30	0.58	1.93	Excel lent		
16			0.09	0.91	0.11	1.22	0.15		0.85	0.37	2.47			
17			0.11	0.89	0.09	0.82	0.07		0.93	0.19	2.71			
18			0.48	0.52	0.45	0.94	0.48		0.52	0.47	0.98		Good	

Table 4.9 Item Discrimination Indices

Point-biserial correlation index, r_{pbi} . The final test item measurement is the point-biserial correlation index (r_{pbi}) for discrimination. This measures the reliability of a single test item. The possible range for the point-biserial correlation index (r_{pbi}) for discrimination is from -1.00 to $+1.00$. Values for the point-biserial correlation index greater than or equal to 0.20 are ideal and indicate the test items are reliable. In Table 4.10, the reliability of each individual test item is shown.

Question Number	Question Sets	Category	Van Hiele Level (VHL)	(r_{pbi})	
				Pre-Instruction	Post-Instruction
1	(i)	M	I	0.57	0.47
2		P		0.41	0.38
3	(ii)	M		0.56	0.43
4		P		0.47	0.46
5	(iii)	M	II	0.30	0.48
6		P		0.22	0.38
7	(iv)	M		0.26	0.42
8		P		0.23	0.29
9	(v)	M	III	0.42	0.46
10		P		0.20	0.17
11	(vi)	M		0.46	0.52
12				0.37	0.52
13				0.33	0.31
14		P		0.33	0.36
15				0.55	0.50
16				0.23	0.50
17				0.21	0.38
18				0.36	0.41

Table 4.10 Item Reliability

All values indicated good reliability except for question 10 on the post–instruction survey (see APPENDIX D.1). This question is difficult for some students because it involves an additional calculation. When solving for the time period and phase shift, the students must consider that each block is 1/10 of a second. They may also become distracted due to the “fuzziness” of the graph as opposed to a smooth line. For these reasons as well as possible other reasons, question 10 is not a reliable test item. This in turn decreases the overall reliability of the survey.

Since the reliability of each individual test item (except question 10 on the post-instruction survey) is good, the survey can be used to predict the total test scores of students from an individual test item (except question 10) on the test. The items are consistent with the students' overall test scores.

4.1.4. Question Order Effects

Although the research questions in this study do not have any relevance to question order effects, the topic has been presented because the order in which questions are presented will influence transfer of learning. For a detailed discussion on order effects see Gray (2004).

The overall result of having four versions of each survey is that question order does affect student responses to questions. The proof of this claim is indicated by the shaded z -scores ($|z| > 1.96$) in Table 4.11 which indicate statistically significant question order effects. An in-depth analysis of question order effects is not one of the purposes of this study, but the analysis was done to make the following point: student responses are affected by the order in which questions are presented and therefore may have a small bias on the results of this study. Further research on the effect of question order is beyond the scope of this study and is an interesting factor to investigate for future research.

Question Number	Pre-Instruction Survey						Post-Instruction Survey					
	V1 <u>vs.</u>			V2 <u>vs.</u>		V3 <u>vs.</u>	V1 <u>vs.</u>			V2 <u>vs.</u>		V3 <u>vs.</u>
	V2	V3	V4	V3	V4	V4	V2	V3	V4	V3	V4	V4
1	0.20	1.55	0.24	1.42	0.05	-1.35	0.79	0.97	0.90	0.19	0.11	-0.08
2	1.79	1.27	0.71	-0.54	-1.10	-0.57	-0.06	1.42	0.71	1.48	0.77	-0.71
3	0.31	1.66	0.44	1.42	0.14	-1.25	0.90	1.76	1.46	0.89	0.58	-0.32
4	-0.09	2.14	-0.67	2.33	-0.60	-2.87	0.73	0.84	0.52	0.12	-0.21	-0.32
5	-1.30	0.85	0.75	2.21	2.10	-0.09	1.16	1.54	1.88	0.41	0.75	0.33
6	-0.35	1.03	-1.07	1.43	-0.76	-2.15	0.47	1.06	-1.19	0.61	-1.65	-2.22
7	-1.40	0.18	-0.12	1.64	1.32	-0.31	-2.06	-1.25	-0.93	0.79	1.13	0.32
8	0.39	0.28	0.36	-0.11	-0.02	0.09	-2.14	-0.84	-2.19	1.27	-0.08	-1.33
9	0.95	-0.41	-0.93	-1.40	-1.94	-0.54	1.47	1.90	0.87	0.45	-0.61	-1.06
10	-0.92	-0.65	1.78	0.28	2.73	2.46	0.10	0.07	-0.07	-0.02	-0.17	-0.14
11	-1.45	-0.43	-0.24	1.05	1.24	0.19	0.19	2.54	-0.45	2.31	-0.63	-2.94
12	1.16	0.65	1.88	-0.52	0.78	1.28	0.16	0.88	1.69	0.71	1.50	0.77
13	0.94	0.85	0.13	-0.09	-0.83	-0.74	-0.02	-0.65	-0.06	-0.62	-0.03	0.59
14	1.66	-0.24	-0.22	-1.95	-1.93	0.01	2.26	1.83	0.67	-0.40	-1.61	-1.19
15	-0.48	0.41	-0.97	0.92	-0.52	-1.43	0.66	1.28	0.06	0.62	-0.60	-1.22
16	0.61	0.56	-0.69	-0.05	-1.33	-1.27	1.59	1.17	1.16	-0.41	-0.46	-0.05
17	1.79	1.41	0.49	-0.39	-1.33	-0.94	0.54	0.84	1.01	0.31	0.46	0.14
18	0.12	-0.38	0.15	-0.53	0.03	0.54	0.03	-0.46	-0.28	-0.48	-0.30	0.19

Table 4.11 Question Order Effects

4.1.5. Addressing the Research Questions

To answer the research questions, the trigonometry sample of students were used in all data analysis.

Research Question # 1: What concepts have the students learned in the trigonometry courses?

Only two methods are available to measure student learning due to the limitations of obtaining additional data as discussed in Section 3.4 – we examined data from the on–

line trigonometry homework assignments and trigonometry course grades. A correlation between student average maximum scores divided by the number of attempts for all on-line homework assignments and course grades was calculated. Student maximum scores divided by the number of attempts were calculated for each homework assignment. These values were averaged for each Van Hiele Level (VHL) for trigonometry and a t -test was used to determine whether the differences in student learning for the VHL's are statistically significant.

The correlation between student average maximum scores divided by the number of attempts for all on-line homework assignments and course grades is 0.21. The number of on-line homework and course grades that were available for this correlation was 43. For 40 students, a correlation value (critical value) greater than or equal to 0.2573 at the 0.10 level is needed to be statistically significant. Forty students were used because as the number of students increase, the correlation value needed for significance decreases. Therefore, 0.21 is less than the critical value for a statistically significant correlation. The results indicate that on-line homework assignments do not correlate with their trigonometry course grades and therefore cannot be used alone as a valid measure to assess student learning.

Figure 4.3 shows a distribution of course grades that are positively skewed, which indicates that students earn satisfactory grades and therefore should be able to transfer their learning. Assuming that the course grades are a valid measure of student learning in trigonometry, based on the non-significant correlation between on-line homework assignments and course grades (0.21), we can conclude that the on-line homework assignments are not a valid measure of student learning. This non-significant correlation

can be explained by the fact that there were evaluation measures other than the on-line homework involved in computing the course grade. According to a trigonometry course syllabus, attendance, class participation, quizzes, and *homework* added to only 29% of the total course grade.

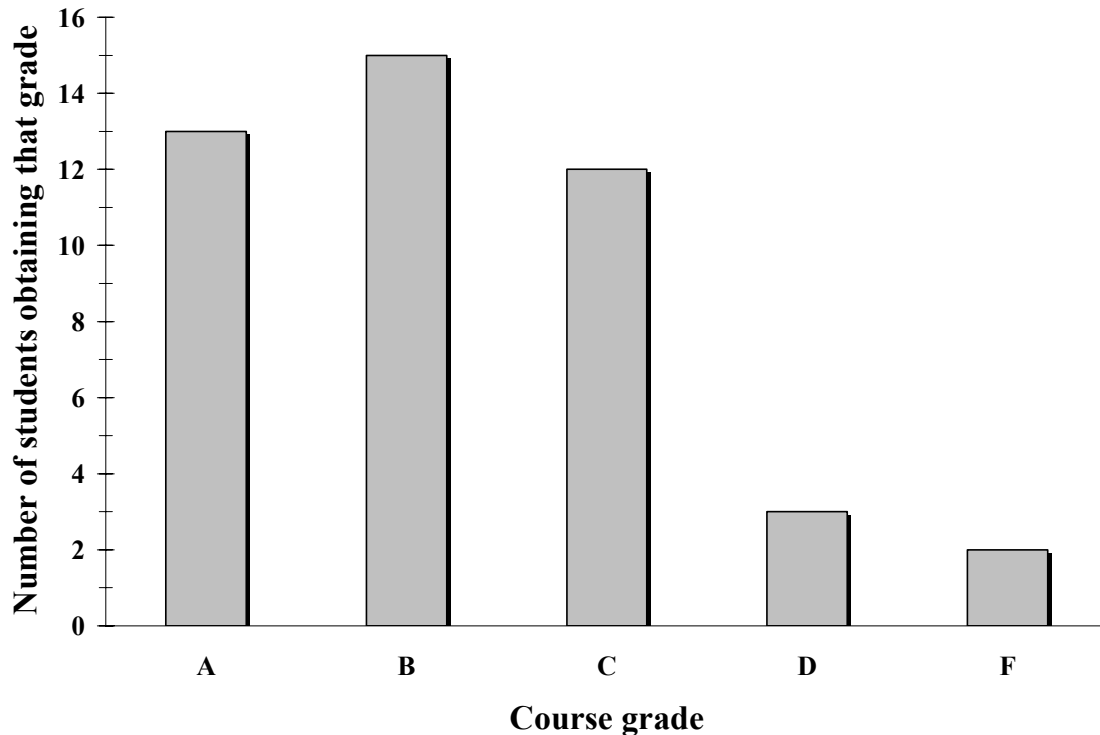

Figure 4.3 Trigonometry Course Grades Distribution

Although the on-line homework grades are not a valid measure of student learning in trigonometry, they were the only measure we had available that allowed us to assess student learning in trigonometry at different VHL's. Students' maximum scores divided by the number of attempts were calculated for each homework assignment. These values were averaged and categorized as pertaining to each of the three VHL's (see

Table 4.12). Figure 4.4 graphically illustrates average student scores divided by the number of attempts for each VHL.

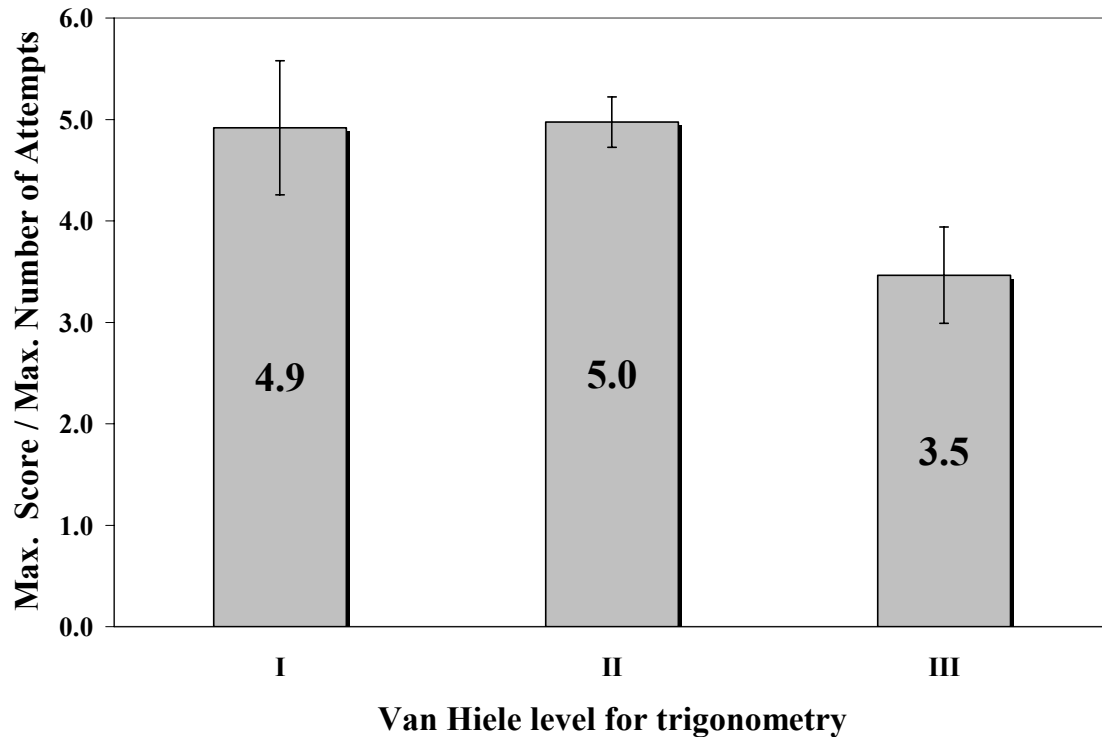

Figure 4.4 Student Learning on On-Line Trigonometry Homework Assignments per Van Hiele Level

According to Figure 4.4, students do not perform as well with VHL-III questions. This data supports the hierarchical arrangement of VHL's in which students must think at VHL-I and -II before they can think at VHL-III. The t -test between VHL-I and -III is 3.64 and between VHL-II and -III is 3.61, which indicates there is a statistically significant difference between those VHL's at the 0.001 significance level.

However, according to Figure 4.4, students' level of thinking is approximately the same in VHL-I and -II. The t -test between VHL-I and -II is 0.11 which indicates that

there is no statistically significant difference between those VHL's. A possible explanation may be explained by the order in which the assignments were administered. Table 4.12 indicates the chronological order in which students completed the on-line homework assignments along with the VHL category of the assignment.

Assignment Number	1	2	3	4	5	6
Van Hiele Level (VHL)	I	II	II	I	III	III
Average Maximum Score Divided by the Number of Attempts	4.5	5.1	4.8	5.4	3.8	3.1
Number of students	44	44	44	46	45	44

Table 4.12 Van Hiele Levels of the On-line Trigonometry Homework Assignments

According to Table 4.12, students were presented the homework assignments that are not in a hierarchic order as opposed to the hierarchy in levels of thinking. Students were assessed on VHL-II content (Assignments 2 & 3) prior to experiencing the remaining VHL-I content (Assignment 4). According to the hierarchical arrangement of VHL's, students thinking at VHL-II are able to think at VHL-I, but they did not receive all the opportunities to learn at VHL-I prior to beginning VHL-II content.

Also, the first on-line assignment included VHL-I questions which had an average maximum score divided by the number of attempts which was lower than Assignments 2-4 (see Table 4.12). In many cases, the first homework assignment typically does not reflect the level at which student's think. The trigonometry context may be quite different to what they may have previously experienced, i.e. the majority of students are kinesiology or biology majors (see Table 3.6) who may not have had a

trigonometry course prior to the one in which the data were collected. The on–line homework system may also be a new experience for some students.

Research Question # 2: What knowledge do the students retain from their trigonometry course when they begin their physics course?

To answer this research question, several analysis procedures were implemented, but limitations of obtaining additional data as discussed in section 3.4 kept us from a more detailed analysis of retention of student trigonometry knowledge. The proportion of students ($n = 43$) who had taken trigonometry previously at K–State that correctly answered questions in each of the Van Hiele Levels (VHL’s) for trigonometry on the pre–instruction survey mathematics (abstract) questions is represented in Figure 4.5.

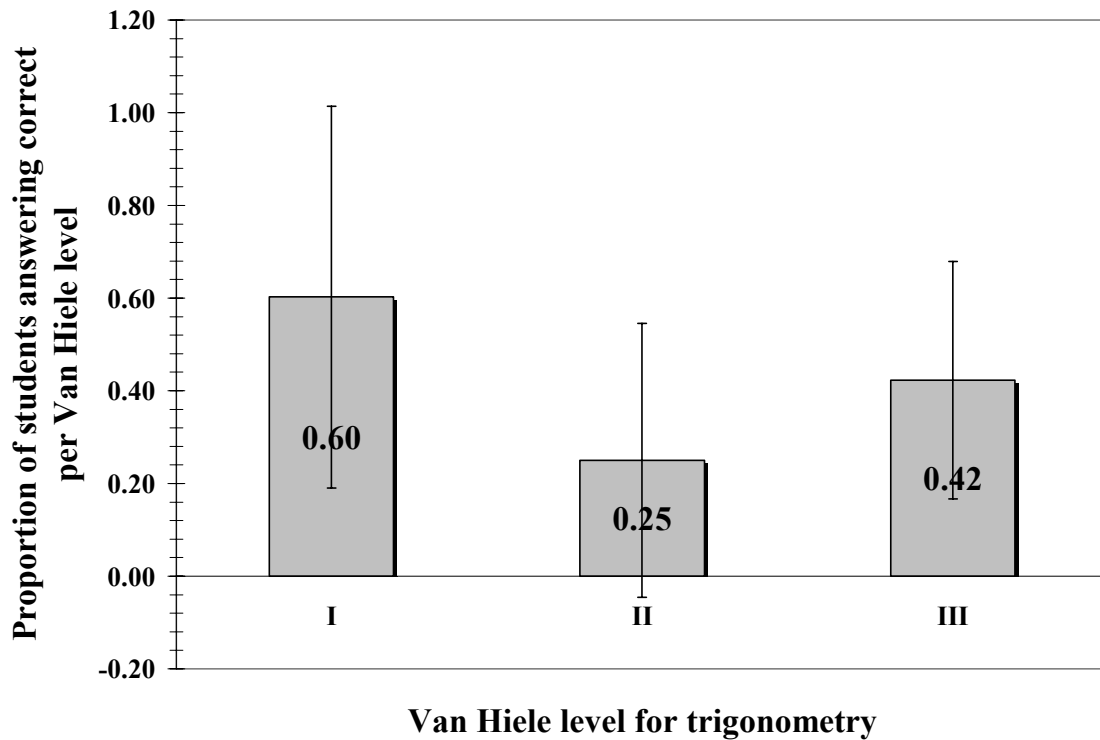

Figure 4.5 Pre-Instruction Survey Mathematics (Abstract) Question Results per Van Hiele Level

According to Figure 4.5, students have more difficulty with VHL-II questions. The t -test between VHL-I and -II is 4.61, between VHL-I and -III is -4.00, and between VHL-II and -III is -7.60. These results indicate that there is a statistically significant difference between all VHL pre-instruction survey mathematics (abstract) question scores at the 0.001 significance level.

Considering the fact that VHL's have a progressively increasing degree of conceptual difficulty, the results shown in Figure 4.5 are anomalous in that a smaller proportion of students (0.25) answered the VHL-II questions correctly than VHL-III (0.42). Comparing these results with that for student learning in the trigonometry course, for the three VHL's as measured by the on-line trigonometry assignments (Figure 4.4),

we find that although students appear to have learned the concepts in VHL's I and II about equally well, they appear to have much greater difficulty in retaining what they have learned in VHL-II than in VHL-I. This result also appears to indicate that the unit circle concept in trigonometry is particularly difficult for students to retain after they have completed the course.

Figure 4.6 show a distribution of the average total score on the pre-instruction survey versus the number of semesters the students completed the trigonometry course prior to taking GP1. According to Figure 4.6, the longer the time period between the courses, the less likely they are to perform well on the pre-instruction survey.

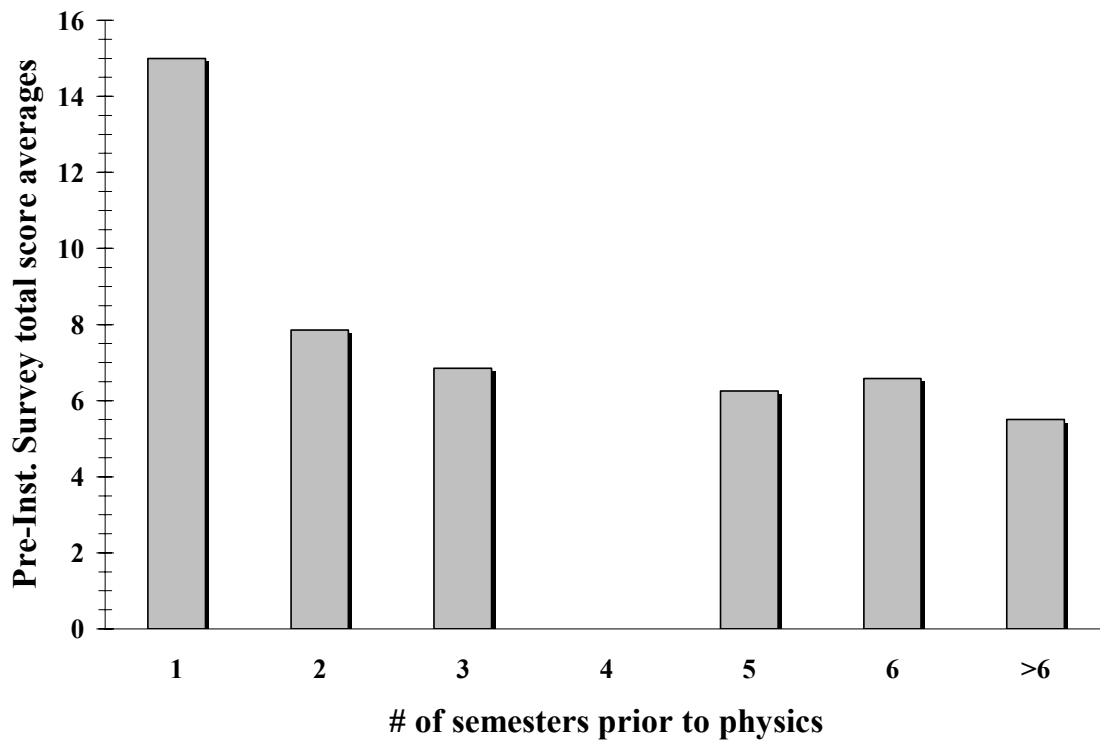

Figure 4.6 Pre-Instruction Survey Scores and Time between Courses

Figure 4.7 shows a normalized distribution of the average total mathematics (abstract) question score in each VHL on the pre-instruction survey versus the number of

semesters the students completed the trigonometry course prior to taking GP1. The maximum score each student could receive is two points for VHL–I questions, two points for VHL–II, and five points for VHL–III. As discussed above, students have greater difficulty in retaining VHL–II concepts and according to Figure 4.7, the difficulty appears to be consistent in time. These data (Figure 4.6 and Figure 4.7) appear to be consistent with conventional wisdom among educators that students retain less content as time progresses.

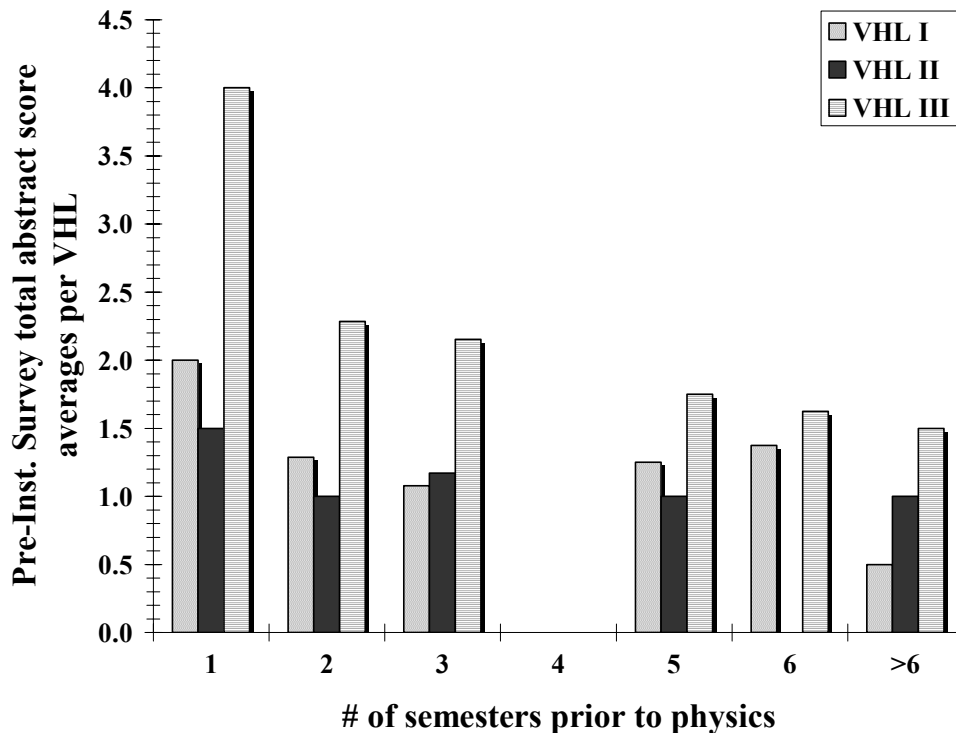

Figure 4.7 Pre-Instruction Survey Mathematics (Abstract) Question Scores per Van Hiele Level and Time between Courses

To further assess student retention of trigonometric concepts, a correlation between student average maximum scores divided by the number of attempts for all on-

line homework assignments and their pre-instruction survey mathematics (abstract) question scores was calculated. Next, a correlation between student pre-instruction survey mathematics (abstract) question scores and their course grades was calculated.

The number of students used in the correlations was different because data for some course grades was not available. The on-line homework assignments do correlate (see Table 4.13) with the pre-instruction survey mathematics (abstract) questions with a significance level of 0.10. Therefore, the on-line homework assignments can predict how well the students will perform on the pre-instruction survey mathematics (abstract) questions, though the correlation is barely significant. However, when we calculate the correlation coefficients between the on-line trigonometry homework assignment scores for each VHL and the corresponding pre-instruction survey mathematics (abstract) questions for each VHL, we find that the correlations (see Table 4.13) are not statistically significant. These results appear to indicate that the on-line homework assignments performance in trigonometry is not a good predictor of student retention in each of the VHL's; however it appears to be a good predictor of their overall mathematical ability as they begin the physics course.

CORRELATION COEFFICIENTS ($n = 43$) On-Line Trigonometry Homework Assignments vs. Pre-Instruction Survey Mathematics (Abstract) Questions	
ALL VHL's	0.25*
VHL-I (geometric level)	0.12
VHL-II (unit circle level)	0.05
VHL-III (function level)	0.05

* $p < 0.10$

Table 4.13 Van Hiele Level Retention Results

The course grades in trigonometry correlate ($r = 0.30$, $df = 43$) with the pre-instruction survey mathematics (abstract) questions at a significance level of 0.05. This result indicates that the course grades in trigonometry are also a good predictor of student retention of trigonometry knowledge as measured by the pre-instruction survey mathematics (abstract) questions.

Research Question # 3: How consistently do students use their understanding developed in trigonometry courses when encountering these ideas in new contexts?

We address this research question from both the traditional notion of transfer as well as the more contemporary perspectives such as Bransford and Schwartz's (1999) 'preparation for future learning' perspective as well as the 'actor-oriented transfer' perspective by Lobato (2003).

Traditional Perspective. Traditional models of transfer observe transfer of learning from the researcher's pre-defined concept which they hope students would transfer. The researchers look for evidence that the students have been able to transfer the pre-defined concept from a context in which the concept was initially learned to a different context. In the traditional models of transfer, transfer is a static/passive process.

The relevant (first six) on-line trigonometry assignments, in terms of VHL's, average maximum score divided by the number of attempts was correlated with the pre- and post-instruction survey physics (contextual) question total scores (see Table 4.14).

Physics (Contextual) Question Total Scores	<i>df</i>	<i>r</i>	<i>z</i>	<i>r</i> significance
Pre-Instruction Survey	37	0.18	—	NS
Post-Instruction Survey	34	0.31*	1.84	NS

* $p < 0.10$

Table 4.14 On-Line Trigonometry Assignments and Survey Physics (Contextual) Question Total Scores

Table 4.14 indicates that there is no statistically significant (NS) correlation between the first six on-line trigonometry assignments and the total score on the pre- and post-instruction survey physics (contextual) questions, even though the correlation for the post-instruction survey is significant (the correlation calculation is not statistically significant). From this analysis of the traditional perspective of transfer, students are unable to successfully transfer their learning from their trigonometry course to their physics pre-test (pre-instruction survey).

We also calculated correlation coefficients between each on-line trigonometry assignment score and the scores on the physics (contextual) questions on the on the pre-instruction survey (see Table 4.15).

On-Line Trigonometry Assignment	Pre-Instruction Survey Physics (Contextual) Questions			
	<i>df</i>	<i>r</i>	<i>z</i>	<i>r</i> significance
1	37	-0.11	—	NS
2	38	0.35**	2.13	0.05
3	38	0.18	—	NS
4	39	0.07	—	NS
5	38	0.08	—	NS
6	38	0.13	—	NS

** $p < 0.05$

Table 4.15 On-Line Trigonometry Assignments and Pre-Instruction Survey Physics (Contextual) Questions Total Score

Table 4.15 indicates that there is only one statistically significant correlation between the first six on-line trigonometry assignments and the total score on the pre-instruction survey physics (contextual) questions. From this analysis of the traditional perspective of transfer, students transfer some of their learning in trigonometry to physics, i.e. VHL-II. The correlation for Assignment #2 is statistically significant; however, for the other assignments there is no statistically significant correlation; therefore we cannot claim that transfer of learning may be measured by looking at the individual on-line trigonometry assignments and the pre-instruction survey physics (contextual) questions.

To gain a better understanding of whether transfer is dependent on the VHL for trigonometry, we calculated the correlation coefficient between the on-line score and the corresponding physics survey questions for each VHL (see Table 4.16). According to Table 4.16, there are no statistically significant correlations for each of the VHL's of the on-line trigonometry assignments and the surveys' physics (contextual) questions.

On-Line Trigonometry Assignment	Van Hiele Level (VHL)	Pre-Instruction Survey Physics (Contextual) Questions				Post-Instruction Survey Physics (Contextual) Questions			
		<i>df</i>	<i>r</i>	<i>z</i>	<i>r</i> significance	<i>df</i>	<i>r</i>	<i>z</i>	<i>r</i> significance
1	I	35	-0.07	—	NS	33	0.20	—	NS
2	II	36	-0.02	—	NS	33	0.03	—	NS
3		36	-0.13	—	NS	32	0.02	—	NS
4	I	37	0.07	—	NS	34	0.29	—	NS
5	III	36	-0.06	—	NS	33	-0.07	—	NS
6		36	0.21	—	NS	32	-0.01	—	NS

Table 4.16 On-Line Trigonometry Assignments and Survey Physics (Contextual) Question Score per Van Hiele Level

The trigonometry course grades were also correlated with the overall pre- and post-instruction survey physics (contextual) questions (see Table 4.17). To further assess

the specific knowledge student's transfer from trigonometry to physics, the trigonometry course grades were correlated with the VHL physics (contextual) questions on the pre- and post-instruction surveys.

Correlation Between Trigonometry Course Grade and	Van Hiele Level (VHL)	Pre-Instruction Survey Physics (Contextual) Questions (n = 44)			Post-Instruction Survey Physics (Contextual) Questions (n = 41)		
		<i>r</i>	<i>z</i>	<i>r</i> significance	<i>r</i>	<i>z</i>	<i>r</i> significance
	ALL VHL's	0.30*	—	NS	0.35**	2.19	0.05
	I	0.35**	2.32	0.05	0.30	—	NS
	II	-0.08	—	NS	-0.01	—	NS
	III	0.28	—	NS	0.39**	2.46	0.05

** $p < 0.05$
 * $p < 0.10$

Table 4.17 Trigonometry Course Grades and Survey Physics (Contextual) Question Score

Table 4.17 indicates that the post-instruction survey overall physics (contextual) questions significantly correlate with the trigonometry course grades. When the trigonometry course grades were correlated with individual VHL's, two statistically significant correlations were measured: VHL-I on the pre-instruction survey physics (contextual) questions and VHL-III on the post-instruction survey physics (contextual) questions. Therefore, the trigonometry course grades are a good predictor of how well the students will perform on the pre-instruction survey physics (contextual) geometric (VHL-I) questions and the post-instruction survey physics (contextual) function (VHL-III) questions. However, the trigonometry course grades are not a good predictor of transfer with unit circle (VHL-II) concepts.

Therefore, the conclusions from the traditional perspective of transfer is that students do not transfer their learning from trigonometry to physics when looking at their on-line trigonometry assignments and the pre- and post-instruction surveys physics (contextual) questions. Although there is a statistically significant correlation between one of the online assignments (# 2) and the pre-instruction survey physics questions, it is not clear evidence of transfer of learning from trigonometry to physics as per the traditional perspective. However, the trigonometry course grades indicate transfer of learning when looking at the post-instruction survey physics (contextual) questions, although there is no consistent evidence of transfer when looking at specific VHL's.

Preparation for Future Learning Perspective. Bransford and Schwartz (1999) provide a contemporary perspective of transfer called “preparation for future learning” (PFL) where the focus is on how students *learn* to solve problems in the new situations. They describe previous transfer studies of all using a final task in the transfer situation where students do not have the typical resources available to them as in the initial learning situation, which they called “sequestered problem solving” (SPS).

Since students were not allowed to use resources during the surveys, a way to measure transfer from the PFL perspective is by looking at each students' gain in scores (i.e. difference between post-instruction score and pre-instruction score) on the physics (contextual) questions and correlate this gain with the on-line trigonometry homework assignments. The correlation coefficient is $r = 0.15$ ($df = 31$). However, this value is not statistically significant. Therefore, from the PFL perspective of overall on-line

trigonometry assignments and gain in survey physics (contextual) questions, students do not transfer their learning through the course of physics instruction.

Another way to measure transfer of learning from the PFL perspective is by correlating the overall pre-instruction survey mathematics (abstract) questions with the gain in survey physics (contextual) questions. The correlation coefficient is $r = -0.32$ where degrees of freedom (df) = 35 and $p < 0.10$. The value of the correlation significance is $z = -1.91$, which is not statistically significant. Therefore, from the PFL learning perspective, overall scores on the on-line trigonometry assignments and the surveys will not measure transfer of learning. A more in depth analysis is needed to determine whether or not students transfer their learning in terms of the PFL perspective.

To obtain a deeper understanding of transfer from the PFL perspective, the on-line trigonometry assignments and the gain in survey physics (contextual) question scores were categorized into the respective Van Hiele Levels and correlated (see Table 4.18).

		Gain in Survey Physics (Contextual) Questions					
		VHL	I	II	III	<i>df</i>	<i>z</i>
On-Line Trigonometry Assignment	I	0.36*			31	2.04	0.05
	II		0.13		31	—	NS
	III			-0.15	30	—	NS

* $p < 0.10$

Table 4.18 On-Line Trigonometry Assignments and Gain in Survey Physics (Contextual) Questions per Van Hiele Level

Table 4.18 indicates that only one statistically significant correlation exists between the on-line trigonometry assignments and the gain in survey physics (contextual) questions. Assignments 1 & 4 correspond to VHL-I and this is the only VHL where there is a

significant correlation coefficient, however only at the 10% level. VHL–III actually has a negative correlation. A possible reason for this is the fact that VHL–III is the highest level in which students think at in the hierarchy of levels. Also, the phase shift questions asked on the pre– and post–instruction surveys may have an effect on student performance possibly because phase shifts were not discussed in GP1.

Another correlation calculation was performed on the pre–instruction survey mathematics (abstract) questions and the gain in survey physics (contextual) questions. Each measure was categorized into the respective VHL’s (see Table 4.19).

	VHL	Gain in Survey Physics (Contextual) Questions			<i>df</i>	<i>z</i>	<i>r</i> significance
		I	II	III			
Pre–Instruction Survey Mathematics (Abstract) Questions	I	0.01			35	—	NS
	II		0.07		35	—	NS
	III			-0.42 ^{***}	35	-2.55	0.05

^{***}
 $p < 0.01$

Table 4.19 Pre–Instruction Survey Mathematics (Abstract) Questions and Gain in Survey Physics (Contextual) Questions per Van Hiele Level

According to Table 4.19, the students’ performance on VHL–I questions do not correlate. Therefore, the PFL perspective does not measure transfer of learning when implemented in this manner. Limitations of additional data would be needed to determine whether transfer of learning occurs when attempting to measure transfer from the PFL perspective. VHL–III questions do correlate with statistical significance, but the correlation is negative. Again, the lack of physics instruction on phase shifts or the technical difficulty of the items may be the factor that is causing students not to transfer

some of their learning from trigonometry to physics (see Table 4.8). According to Table 4.8, the only two negative item difficulty index differences were for the two phase shift questions. Therefore, to possibly acquire a deeper understanding of what has been discussed up to this point and also to answer some of questions dealing with phase shifts, transfer will be looked at in terms of the measurement instruments (survey) themselves which is discussed in the actor-oriented transfer perspective.

Finally, another albeit cruder method to analyze transfer from the PFL perspectives is a correlation between the *Trigonometry* course grades and the *General Physics 1* (GP1) course grades. Here the assumption is that the GP1 course grades are a measure of learning in the course. We find that the correlation coefficient is $r = 0.54$ where degrees of freedom (df) = 41 and $p < 0.001$. A z -test was then calculated to determine the significance of r . The value of the correlation significance is $z = 3.5$ where $p < 0.05$. Therefore, as per the PFL model of transfer, students are able to transfer their knowledge from the *Trigonometry* course to the *General Physics* course. However, when we calculate the correlation coefficient between the on-line scores in trigonometry and the pre-instruction survey physics scores, as was done before, no evidence of transfer was found.

Actor-Oriented Transfer Perspective. Lobato (2003) conceives transfer as the *personal construction of similarities between activities* (how actors see situations as similar). In the traditional model, transfer is defined as applying what one has learned in one situation to another situation (Reed, 1993; Singley and Anderson, 1989). Lobato argues that we should extend transfer theory beyond the traditional models of transfer

where researchers pre-define the concept which they hope one would transfer and adopt a more student-centered perspective to have a better understanding of the factors that facilitate transfer.

Traditional models look for improved performance as a measure of transfer while Lobato examines transfer by looking at the nature of situations and the similarities that people construct across situations. Evidence for transfer is gathered by scrutinizing a given activity for any indication of influence from previous activities rather than predetermining which responses count as evidence of transfer and which do not (Lobato, 2003). Therefore, to examine transfer of learning from the actor-oriented perspective, several methods of analysis were applied.

The first analysis of transfer in the actor-oriented perspective is by correlating the pre-instruction survey mathematics (abstract) questions with the pre-instruction survey physics (contextual) questions and the post-instruction survey mathematics questions with the post-instruction survey physics questions to determine whether or not transfer is occurring in the survey itself (see Table 4.20). In Table 4.20, mathematics questions were also correlated with the similarly designed physics questions; i.e. M1 & P1 were questions that are almost identical in the sense of the same trigonometric concept, except one being abstract and the other contextual.

Correlation Between		Pre-Instruction Survey				Post-Instruction Survey			
Mathematics (M)		df	r	z	r sig.	df	r	z	r sig.
Physics (P)									
ALL M & P		42	0.66****	4.33	0.05	39	0.44***	2.77	0.05
ALL M & P per VHL	VHL								
	I	42	0.79****	5.15	0.05	39	0.53****	3.37	0.05
	II		-0.01	—	NS		0.20	—	NS
	III		0.76****	4.97	0.05		0.39**	2.48	0.05
M1 & P1	42	0.61****	4.01	0.05	39	0.21	—	NS	
M2 & P2		0.57****	3.72	0.05		0.45****	2.85	0.05	
M3 & P3		0.11	—	NS		0.04	—	NS	
M4 & P4		-0.05	—	NS		0.28*	1.76	NS	
M5 & P5		0.07	—	NS		-0.01	—	NS	
M6 & P6		0.68****	4.44	0.05		0.49****	3.08	0.05	
M7 & P7		0.35**	2.30	0.05		0.55****	3.50	0.05	
M8 & P8		0.55****	3.59	0.05		0.13	—	NS	
M9 & P9		0.32**	2.11	0.05		0.15	—	NS	

**** $p < 0.001$

*** $p < 0.01$

** $p < 0.05$

* $p < 0.10$

Table 4.20 Pre- and Post-Instruction Survey Question Correlations

According to Table 4.20, the correlation between the overall questions both abstract and contextual in nature is statistically significant for both surveys as well as when the questions are categorized into VHL-I and -III. Therefore, dynamic transfer within the pre- and post-instruction surveys is probable.

However, the abstract and contextual VHL-II questions do not correlate with each other. The VHL-II questions correspond to M3 & P3 and M4 & P4. For many students on the first day of recitation when the pre-instruction surveys were distributed, they may not recall the equation relating the arc length, radius, and angle which is needed in order to successfully solve questions M3 & P3. By inspection, the M4 & P4 set of questions do

have a significant correlation on the post–instruction survey as opposed to a negative correlation on the pre–instruction survey but the significance of r is not statistically significant. Upon further inspection of the VHL–II questions by individual versions, version 3 was the only version in which there were negative correlations for both the pre– and post–instruction surveys. Therefore, version 3 does not aid in transfer of learning at VHL–II.

Another method of looking at transfer from the actor–oriented perspective is through a correlation between the pre– and post–instruction gains on the mathematics (abstract) and physics (contextual) questions. Table 4.21 displays the correlations of the gain for all questions as well as for individual VHL’s.

Correlations Between		<i>df</i>	<i>r</i>	<i>z</i>	<i>r sig.</i>
Gain in Mathematics & Physics		35	0.36**	2.16	0.05
Gain in Mathematics & Physics per VHL	VHL				
	I	35	0.22	—	NS
	II		-0.01	—	NS
	III		0.42***	2.54	0.05

*** $p < 0.01$

** $p < 0.05$

Table 4.21 Pre– and Post–Instruction Survey Gain and per Van Hiele Levels

Table 4.21 reveals that a statistically significant correlation exists between student gain in mathematics (abstract) questions and their gain in physics (contextual) questions as well as when looking at VHL–III questions. However, there is no significant correlation when looking at VHL–I and –II questions and once again a negative correlation for VHL–II. Thus, actor–oriented transfer does not occur uniformly across all VHL’s.

Thus to summarize our findings pertaining to transfer of learning from trigonometry to physics, we find very limited evidence of transfer from trigonometry to physics as per the traditional perspectives of transfer assessment. However, when we broaden our perspectives to include especially the actor-oriented transfer perspective, we find that there is evidence of transfer. Transfer does not occur uniformly across all VHL's.

4.2. INTERVIEW RESULTS AND DISCUSSION

The purpose of the interviews was to investigate students' reasoning at the various Van Hiele Levels (VHL's) for trigonometry. The interviews were designed to gain a deeper understanding of what trigonometry knowledge students retain and what triggers them to transfer their initial knowledge (trigonometry) to a new situation (physics problem). Within this section, "pilot interviews" will be referred to as the first three interviews (same students for all three sets of interviews) conducted in which the interview material was modified upon completion. The term "interviews" will be referred to as the final ten interviews in which we will base our interview results and discussions.

4.2.1. First Set of Interviews

The first set of interviews consisted of three VHL-I (geometric level) questions in the contexts of projectile motion, displacement, and forces. Students were first given a physics question, and then provided with a prompt in the form of a figure that may prompt them with the trigonometry concepts related to the physics question. The

interviews were conducted after instruction and testing on the concepts of projectile motion, displacement, and forces.

Modifications to First Interview Protocol after Pilot Interviews

Upon completion of the pilot interviews, several changes were made to the interview protocol. The first modification was splitting the questions asked about the previous exam into two separate questions so that the students may possibly describe their thinking in more depth. An addition to the interviews was in providing equation sheets for the students because the pilot interviews revealed difficulty in recalling the relevant equations and since our interviews were not focused on student memory of the equations; we felt that providing them with an equation sheet would not bias our study. Questions asking students to describe the mathematical and physics concepts that are needed to solve the contextual (physics) questions were also split into two parts. However, students did not seem engaged and some became very frustrated when asked the conceptual questions; therefore, we will not be discussing responses to these questions and as a result we have dropped these questions from the second and third sets of interviews. Finally, Question 03 was eliminated after the pilot interviews due to time constraints and will not be discussed here. The entire transcript of the protocol for Interview I is in Appendix G.4.

Question 01 of the First Interview

Question 01

Larry is running off the end of a pier with the intention of jumping in the water 4.0 meters below. There's a buoy 6.4 meters from the end of the pier that marks the point where the water's deep enough to safely jump in. Assuming Larry leaves the pier going straight out (horizontal) and air resistance is negligible,

- a. how fast does he have to be running in order to make it past the buoy?
- b. what is the horizontal velocity component *just before* he hits the water?
- c. what is the vertical velocity component *just before* he hits the water?
- d. at what angle does he hit the water with respect to the horizontal?

Figure 4.8 Question 01 of the First Pilot Interview

Question 01 part (a) was eliminated after the pilot interview because this part does not require students to transfer trigonometry to physics (see Figure 4.9). Rather, Question 01 was modified to include an initial speed for the object. Part (c) in Question 01 on the interviews was added in order to observe student retention of the Pythagorean Theorem (VHL-I). One additional modification to the interviews was in providing the correct answers for parts (a) and (b) of Question 01 for the last five interviewees. None of the first five interviewees successfully solved these two parts. The purpose of the interviews is to observe transfer from trigonometry to physics and parts (a) and (b) do not require students to use their trigonometry knowledge to correctly solve these questions, therefore these answers were provided.

Question 01

Larry is running off the end of a pier with the intention of jumping in the water 4.0 meters below. There's a buoy 6.4 meters from the end of the pier that marks the point where the water's deep enough to safely jump in. Larry leaves the pier with an initial speed of 7.0 m/s going straight out (horizontal) in order to make it past the buoy. Assume air resistance is negligible.

- What is the horizontal velocity component *just before* he hits the water? *Answer* = $7.0 \frac{\text{m}}{\text{s}}$
- What is the vertical velocity component *just before* he hits the water? *Answer* = $-8.85 \frac{\text{m}}{\text{s}}$
- What is his speed *just before* he hits the water?
- At what angle does he hit the water with respect to the horizontal?

Figure 4.9 Question 01 of the First Interview

Students were introduced to Figure 01 (see Figure 4.10) to help them recall the correct sine and cosine relationships they may need in Question 01. Students showed no difficulty in the pilot interviews in correctly answering the following questions pertaining to Figure 01 of the First Interview: “What does A equal to in terms of C?” “What does B equal to in terms of C?” Since these questions were too easy for the students, they were replaced with the following question: “What does C equal to in terms of A and B?”

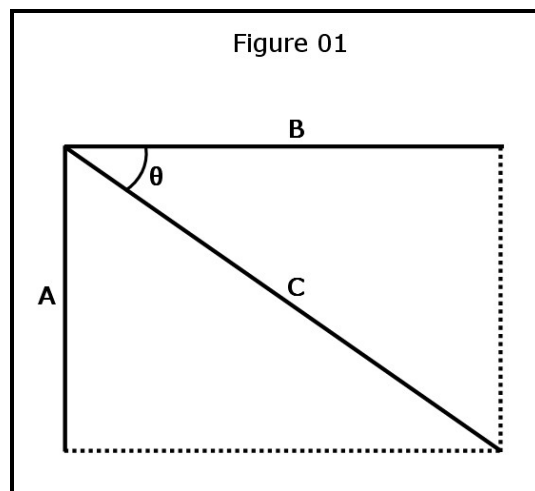

Figure 4.10 Figure 01 of the First Interview

Figure 02 (see Figure 4.11) was added to cue students to the correct trigonometric concept that was applicable to Question 01.

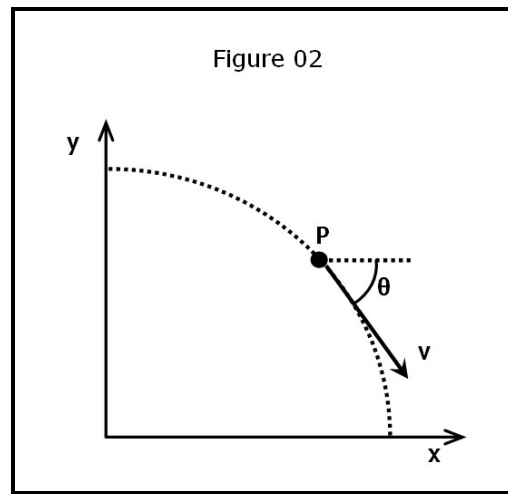

Figure 4.11 Figure 02 of the First Interview

Question 01 assesses student transfer of VHL-I (geometric level) knowledge in the context of projectile motion. One student (Student 7 – S7) of the ten interviewees was able to correctly solve Question 01 parts (c) and (d) without prompting. When presented with question pertaining to the abstract trigonometry figure, Figure 01, she was able to provide the correct responses. Therefore, one out of the 10 students had no difficulty with the physics (contextual) and mathematics (abstract) questions; thus at least one out of the 10 students appear to have retained VHL-I concepts.

As previously mentioned, the first five interviewees were not provided with answers to parts (a) and (b). Many of these students had misconceptions. The most frequent misconceptions were interchanging velocity and acceleration components, i.e. horizontal acceleration is equal to gravity (S3) and vertical velocity is equal to gravity (S1).

Once students were not able to solve Question 01, Figure 01 was presented and the questions pertaining to Figure 01 were asked. All students except for S4 were able to correctly use the Pythagorean Theorem. S4 responded to this question by correctly applying the sine function, although he did not answer the question. Thus, nine out of 10 students were able to retain knowledge of the Pythagorean Theorem (VHL-I).

Students were then asked the following question pertaining to Figure 01: “What does θ equal to in terms of A and B?” S1, S2, S6, S7, S8, S9, and S10 were able to correctly answer the second question pertaining to Figure 01. S6 was also able to correctly answer the second question, but only after the interviewer said “You have permission to change Figure 01, does that help?” S2 immediately said the correct solution, but then took it a step further and said tangent is equal to sine over cosine. The only student (S4) that did not correctly answer the first question pertaining to Figure 01 became very frustrated with the second question and said “I don’t know.” Another student (S3) replied to the second question with a numerical value of 45 degrees. S5 responded to the question by saying “theta plus the angle between A and C is equal to 90 degrees.” Although what he said was true, he neglected to answer the question asked. Thus, seven out of the 10 students were able to retain knowledge of the tangent function (VHL-I).

When asked the questions pertaining to Figure 01, S7, S8, and S10 were able to directly relate the variables A, B, C, and θ of Figure 01 to Question 01 in terms of the speed, velocity components, and the angle just before the object in the problem hits the water. S2, S4, and S5 did not have time to answer these questions, therefore we moved on to Question 02. The remaining students (S1, S3, S6, and S9) related the variables to

distances. The variables may be thought of as distances; however these students were not prompted by the mathematics (abstract) figure to directly relate what was asked in the physics (contextual) problem.

Of the three students (S7, S8, and S10) who did relate the variables of Figure 01 to Question 01 in terms of the speed and its components, S7 was the only student to correctly solve Question 01 prior to the questions pertaining to Figure 01. S10 solved Question 01, however her response to parts (c) and (d) were not correct. Her answer to part (c) was incorrect because she used the hypotenuse of the triangle as the change in horizontal distance when solving the equation: $v_f^2 = v_i^2 + 2a\Delta x$ instead of simply using the velocity components provided. She also demonstrated a shared a common misconception with three other students (S1, S3, and S9). S10's solution to part (d) is shown in Figure 4.12 and S3's solution is shown in Figure 4.13.

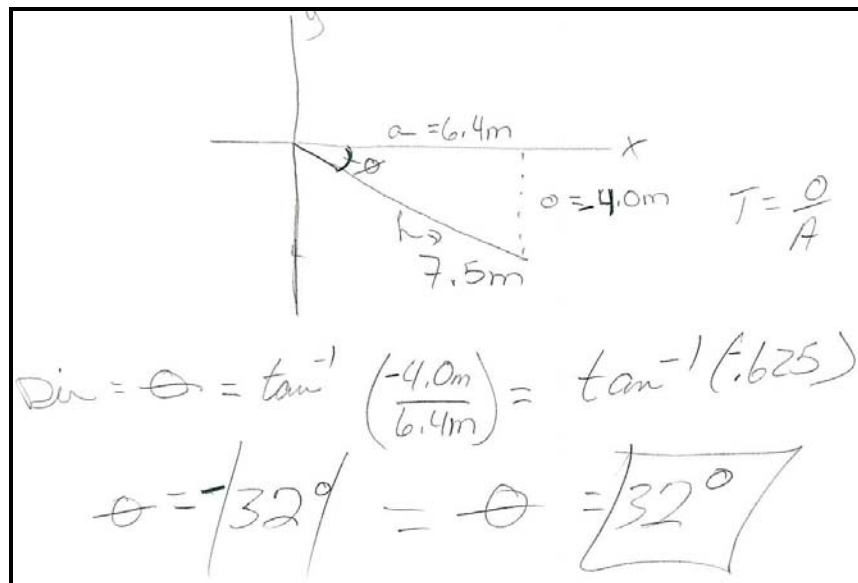

Figure 4.12 Response One to First Interview Question 01 Part (d)

These students correctly applied the arctangent function; however they used distances as opposed to velocity components to find the angle θ .

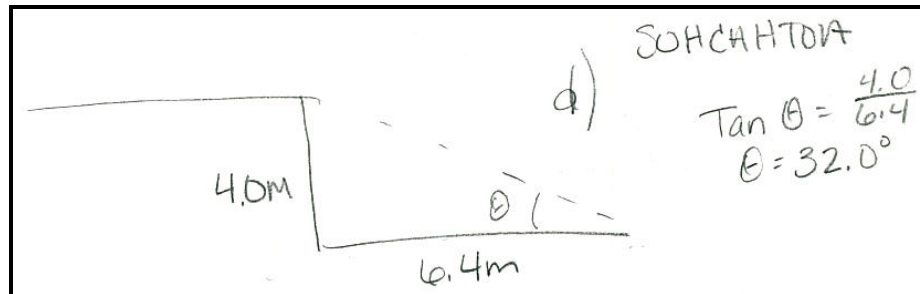

Figure 4.13 Response Two to First Interview Question 01 Part (d)

The final student (S8), who directly related the variables of Figure 01 to Question 01 in terms of the speed and velocity components, illustrates how an abstract figure prompted her to transfer her trigonometry knowledge to the physics question. S8 began to solve Question 01 part (c) when she realized that she was only solving for the horizontal distance which was already provided in the question. Next, she completed part (c) with the correct answer; however she expressed her feeling that she was not sure. When given Figure 01 and asked the protocol questions pertaining to Figure 01, she correctly responded to all questions. Before the interviewer could ask the question “Now try to solve Question 01,” she immediately went back to Question 01 and correctly solved for the angle. When asked “Did anything at all about Figure 01 prompt you to solve Question 01? If so, what?” she said that the (abstract) figure made her more sure of her solution to part (c).

S1 correctly solved part (a) and then was not able to solve the rest of the question. She correctly responded to the first two questions pertaining to Figure 01 and as mentioned above she related the variables in Figure 01 to distances. When she responded

to all questions pertaining to Figure 01, she then correctly solved part (b) of the physics question, but became confused on part (c) and immediately went to part (d) where she correctly used the tangent function to solve for the angle. But in part (d) she used distances even though she correctly solved for each velocity component. S1 then said “I don’t know what to do,” so the interviewer asked questions pertaining to Figure 02 and she responded by saying the x and y components. Next S1 began to use the Pythagorean Theorem to solve for part (c), but used the distances and soon realized her value of 5.8 was not correct. When asked “Did anything at all about Figure 01 or Figure 02 prompt you to solve Question 01? If so, what?” she immediately said “why theta here (pointing to figure 02), angle theta, angle he hit with respect to the horizontal.” Therefore Figure 02 did prompt her to use the Pythagorean Theorem to solve part (c); however she used distances instead of velocity components and did not provide a correct response.

According to several students’ comments after responding to Figures 01 and 02, the Figures did not prompt them to solve Question 01. For example, S3 responded by saying “I don’t know how to do this” when asked “Now try to solve part (c) in Question 01.” Another student, S6, was asked “Is there anything in Question 01 part (a) that is represented in Figure 01” and his reply was “not that I see.” Therefore, for several students, the abstract, trigonometry Figures did not prompt them to transfer their trigonometry concepts to the contextual, physics question.

As indicated by the results of the First Interview Question (01), students do retain VHL-I (geometric level) concepts. Nine out of the 10 students retained and correctly applied the Pythagorean Theorem (VHL-I). Seven out of 10 students retained and correctly applied the tangent function to various right triangles (VHL-I). However, the

protocol questions on the mathematics (abstract, trigonometry figure) Figures (01 and 02) prompted three of the nine students who were not able to solve Question 01 to transfer their trigonometry knowledge and solve the physics (contextual) question. Only one of these three students provided a correct solution, even though she was not certain.

Question 02 of the First Interview

Question 02

What is Larry's resultant displacement from the origin if he takes a walking tour with the following four parts described below?

Part 1: A = 400 meters at 30° east of north.
Part 2: B = 200 meters at 20° south of east.
Part 3: C = 850 meters at 60° north of west.
Part 4: D = 300 meters due south.

Figure 4.14 Question 02 of the First Interview

Question 02 (Figure 4.14) was taken directly from the physics exam which occurred several days prior to the interviews. Figure 03 (Figure 4.15) corresponds to Question 02, but Figure 03 was not shown to students when they were asked to solve the question – Figure 03 was provided only when they were having difficulty drawing the vectors.

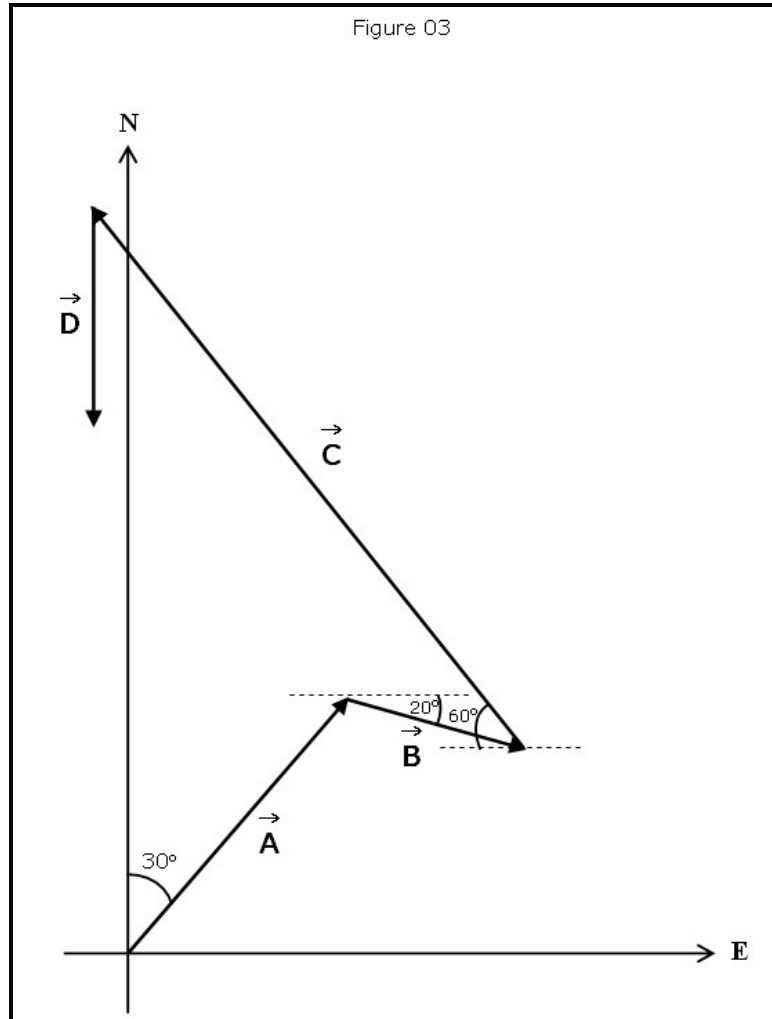

Figure 4.15 Figure 03 of the First Interview

When students had difficulty with Question 02, they were presented with Figure 04 (Figure 4.16). No changes were made to Question 02; however the pilot interviews resulted in difficulty with correct responses to questions pertaining to Figure 04 – similar to those for Figure 01 that was previously discussed.

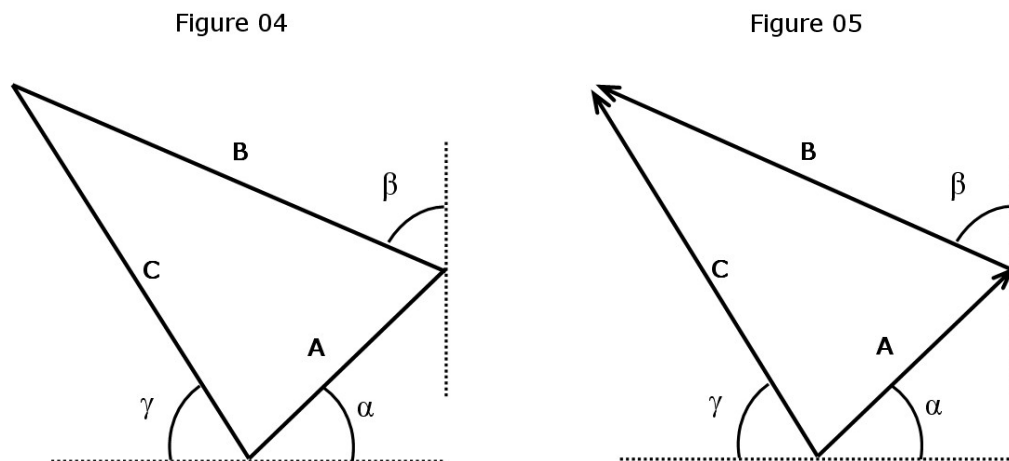

Figure 4.16 Figure 04 and 05 of the First Interview

In an effort to prompt students to solve the questions pertaining to Figure 04, Figure 05 was added to the protocol. The difference between Figures 04 and 05 is that Figure 05 includes arrows instead of solid lines to hopefully prompt students that arrow C may be thought as the resultant displacement of arrows A and B.

Similar to Question 01, Question 02 also assesses whether students can transfer their knowledge of VHL-I concepts to physics problems. Six students (S1, S6, S7, S8, S9, and S10) were able to apply their VHL-I knowledge and correctly solve the components of the displacement in Question 02 without prompting. Of these six, three students (S7, S8, and S10) expressed their answers in terms of a magnitude and an angle; the remaining three students (S1, S6, and S9) wrote their answers in vector component form. However, S8 wrote the direction of the angle incorrectly. After the interview she requested to look at Figure 03 and said that she thought the physics course instructor had told the class that the displacement should be on the positive x -axis. She knew that the angle she calculated was West of North, however she said East of North because she

thought she heard the instructor say on the positive x -axis. Therefore, six out of the 10 students had no difficulty with the physics (contextual) question; at least six out of the 10 students have retained VHL-I concepts.

When presented with the Figure 04, only one student (S10) of the six who correctly solved for the displacement components was able to provide the correct responses to the questions pertaining to Figure 04. When Figure 05 (same as Figure 04 except arrows instead of solid lines) was presented to the other five students, two students (S7 and S8) were prompted to solve all questions pertaining to Figure 05. S8 provided the correct responses to Figure 05. S7 responded to all questions and correctly applied the trigonometric functions; however, she overlooked a negative sign when solving for the horizontal components. A possible reason may be due to Figure 05 not including a coordinate system. The remaining three students (S1, S6, and S9) were not able to begin a solution to the questions pertaining to Figure 05. Thus, three of the six students who correctly solved Question 02 without prompting were able to relate the abstract Figures (04 and 05) to the concept of displacement.

The other four interviewees (S2, S3, S4, and S5) were not able to solve Question 02. One student (S2) was not able to draw a diagram to begin his solution, therefore Figure 03 was provided. S3 drew a correct figure, but requested Figure 03 anyway. S4 and S5 also drew correct figures, but were not able to solve Question 02.

S2 correctly solved for the North and East components of vectors A and B in Figure 03 and then stopped. He paused then said, "I know to add all x 's, all y 's, then use the Pythagorean Theorem to get distance, to get the angle negative tangent of final x and y value, each distance has an x and y component." He then said that he was mixing up

the components and they are not correct due to different trigonometry functions being used to calculate the components in the East or North direction, i.e. for the components in the East direction he used the sine function for vector A and the cosine function for vector B. At this point he became frustrated and therefore the interviewer went to Figure 04 and then Figure 05 where he was unable to provide a response to either Figure.

When S3 was given Figure 03, additional prompting was necessary in order for her to be solving Question 02. The interviewer asked if she remembered how to find the components of vector A. S3 responded by writing the cosine and sine functions with the correct value for the hypotenuse, however she used the variable 'x' in both equations. She was unable to provide a response to either Figure 04 or 05.

S4 was unable to make any progress after drawing correct vectors for Question 02 and was not able to provide a response to Figures 04 or 05.

S5 held some misconceptions that kept him from correctly solving Question 02. He began his solution by correctly solving for the vertical components of parts 1 and 2, but then used the horizontal component of part 3 (= 839). Next, he added the magnitudes of each vector, i.e. $400+200+850+300=1750$ and then said, "now need to add vector components up, cosine should be in x and sine in y ." So he added the values for parts 1–3 (839) and subtracted that number from the total magnitude of all vectors (1750). He then said "I am doing something wrong." When he was presented with Figure 04, he responded to the questions pertaining to Figure 04 by saying " $C = \sin \beta$ " and for the second question he said " $\cos \gamma = C$ ". He then provided the same responses to identical questions pertaining to Figure 05.

As indicated by the results of Question 02 in the First Interview, a majority of the students do retain VHL–I (geometric level) concepts. The majority of students retained and correctly applied the cosine and sine function to various right triangles, but one student was uncertain of his application of the functions (even though they were correct) and another used the same variable (x) for both horizontal and vertical components. The protocol questions on the mathematics (abstract trigonometry figure) Figures (04 and 05) do not prompt students to transfer their learning. Only three of the 10 students were able to correctly respond to those questions; however, they were also students who had previously provided a correct solution to Question 02.

4.2.2. Second Set of Interviews

The second set of interviews consisted of VHL–I (geometric level) and –II (unit circle level) questions in the contexts of forces, rotational motion, and bodies in equilibrium. The interviews were conducted after instruction and testing on the concepts of forces, rotational motion, and bodies in equilibrium.

Modifications to Second Interview Protocol after Pilot Interviews

Several students rotated their paper when solving the first interview questions; therefore, the question asking them why they rotated their paper was added. Results of all the second and third sets of interviews indicated that students rotated their paper to get the triangle in a familiar orientation – how they typically visualize triangles – i.e. having at least one side of the triangle parallel to the edge of the table in front of them.

Follow-up questions asking students “Why?” were asked after all figure questions to hopefully gain a deeper understanding of their mathematical thinking. Additional prompting questions were added to the interview protocol at various points in order to appropriately prompt students to begin solving the questions.

Question 01 of the Second Interview

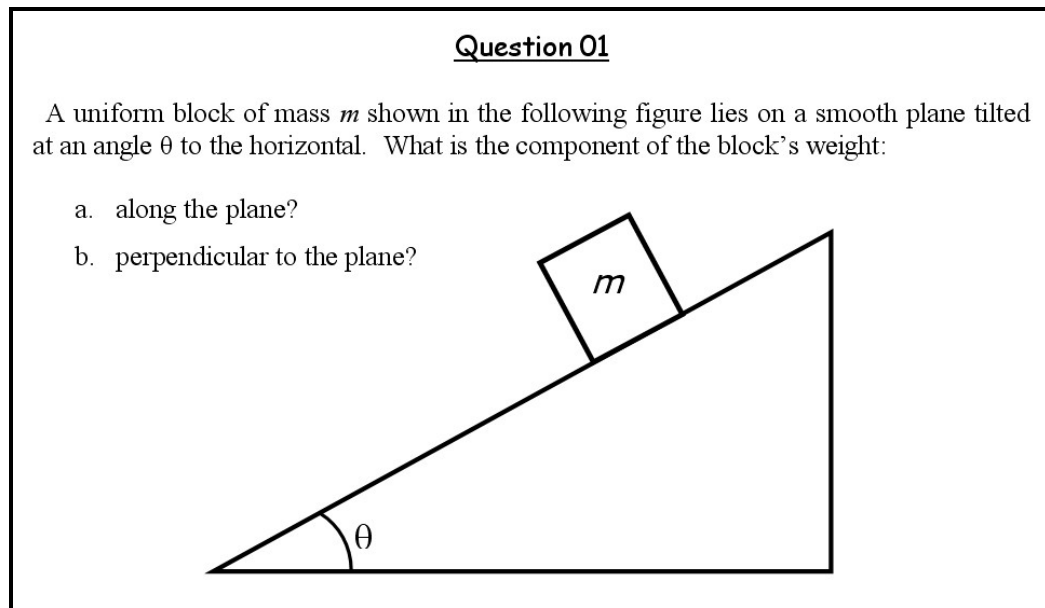

Figure 4.17 Question 01 of the Second Interview

Question 01 (see Figure 4.17) of the second set of interviews consists of VHL-I (geometric level) knowledge in the context of forces. Three students (S7, S8, and S10) were able to correctly solve Question 01 as well as all questions pertaining to Figures 01 through 03 (see Figure 4.18). Therefore, three out of the 10 students did not have difficulty with the physics (contextual) and mathematics (abstract) questions; at least three of the 10 students have retained VHL-I concepts.

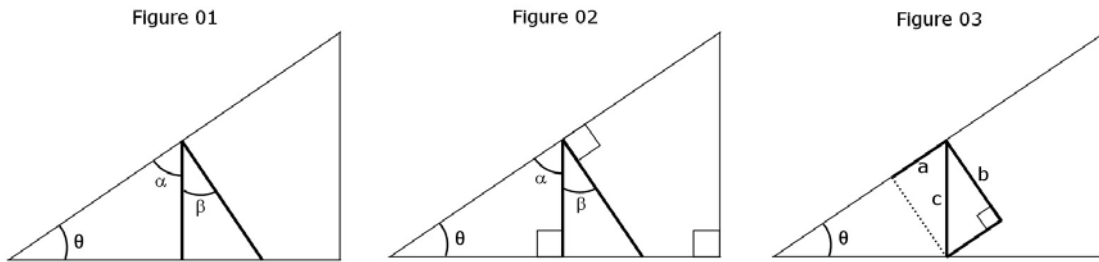

Figure 4.18 Figures 01 through 03 of the Second Interview

S6 was able to correctly apply the trigonometric functions (VHL-I concepts); however, he did not respond correctly to Question 01 because he misplaced the angle ‘ θ ’ on his diagram. When he was asked the questions pertaining to Figure 01, he correctly responded to ‘ α ’ in terms of ‘ θ ’ but could not solve for ‘ β ’ in terms of ‘ θ ’ – so Figure 02 was then presented. He reasoned correctly that “ $\alpha = 180^\circ - (\theta + 90^\circ)$ ” and “ $\beta = 90^\circ - \alpha$ ”, but could not solve the algebra for ‘ β ’ in terms of ‘ θ ’. S6 has retained VHL-I concepts; however, he was not able to correctly solve the two algebraic equations.

S2 and S5 were not able to correctly solve Question 01 due to multiple misconceptions – trigonometry as well as physics. S2 did not provide responses to Question 01 and S5 responded to part (a) by saying “ $\sin \theta$ (m)” and for part (b) “straight down due to mass times gravity.” When presented with the questions pertaining to Figure 01, S2 responded by saying “all three angles add up to 180 degrees, if I know two sides or two angles I can figure out what the angle is.” S2 proceeded by writing the following equation on his worksheet: $90^\circ + __\circ + __\circ = 180^\circ$; and then said that he knows the two angles (blanks) equal 90 degrees; however he did not place ‘ α ’ or ‘ θ ’ in the blanks to complete his equation. Instead S2 used other variables and wrote: $b + c = 90^\circ$ after subtracting 90° from 180° . Thus, S2 knew how to begin the first question

pertaining to Figure 02, but was not able to correctly solve for ' α ' in terms of ' θ '. S5 responded to both Figures 01 and 02 by saying " $\alpha = \sin \theta$ " and " $\beta = \arctan \theta$." When presented with Figure 03, S5 began to explain his solution by relating Figure 03 and the questions pertaining to Figure 03 to a surveying class he was also taking during the same semester. S5's response was " $a = \text{tangential}$, $c \sin \theta$, $c \tan \theta$, but that doesn't seem right, \tan is sine over cosine..." and he did not make any additional progress on Figure 03. Thus, S2 and S5 have not retained VHL-I concepts.

S1 was not able to correctly solve Question 01; however, she provided correct responses to all questions pertaining to Figures 01 and 02. When presented with Figure 03, she correctly answered the protocol questions. Then S1 was asked the questions relating the variables in Figure 03 to the physical quantities in Question 01; she correctly responded to all questions. Thus, S1 has retained VHL-I concepts and was prompted by the mathematical (abstract) figures to transfer her trigonometry knowledge to the physics (contextual) question.

Three students (S3, S4, and S9) were also not able to solve Question 01. When presented with Figures 01, 02, and 03, they were able to correctly respond to the protocol questions asked about the variables ' α , β , a , and b '; however they were not able to directly relate the variables in the Figures to Question 01. Thus, S3, S4, and S9 retained VHL-I concepts but were not prompted by the mathematical (abstract) figures to transfer their trigonometry knowledge to the physics (contextual) question.

As indicated by the results of the Second Interview Question 01, eight of the 10 students retained VHL-I (geometric level) concepts. The majority correctly applied the cosine and sine functions to various right triangles and correctly implemented other

trigonometry concepts, i.e. angles inside a right triangle equal 180° or the sum of the angles on one side of a straight line equal 180° . However, the protocol questions on the mathematics (abstract trigonometry figure) Figures (01 – 03) prompted only one out of seven students who were not able to solve Question 01 to transfer her trigonometry knowledge and correctly solve the physics (contextual) question.

Question 02 of the Second Interview

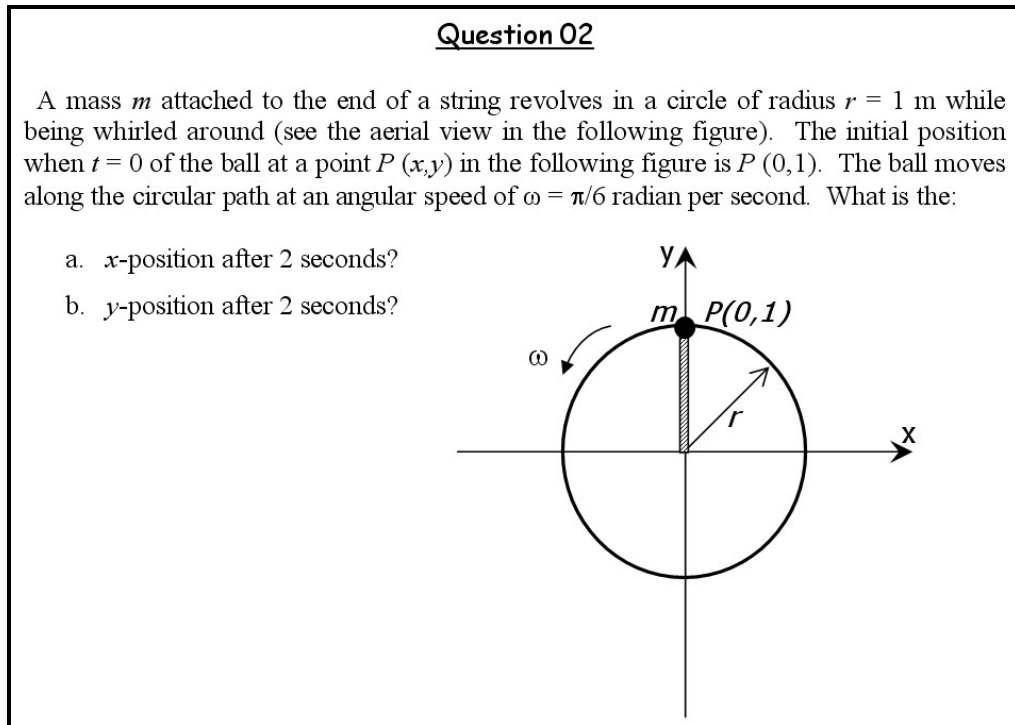

Figure 4.19 Question 02 of the Second Interview

Question 02 (see Figure 4.19) of the second set of interviews consists of VHL-II (unit circle level) knowledge in the context of rotational motion. Additional prompting questions were added to the interview protocol in order to possibly help students begin

solving Question 02. The pilot interviews resulted in students being either unable to solve for or incorrectly solving for the angle in Question 02

Three students (S4, S6, and S8) were able to correctly solve Question 02 without prompting. S4 and S8 were also able to correctly respond to all questions pertaining to Figures 04 and 05 (See Figure 4.20). S6 correctly solved ‘ α ’ in terms of ‘ β ’ (VHL–I) when presented with Figure 04, but became confused with the remaining questions pertaining to Figures 04 and 05. Therefore, three of the 10 students had no difficulty with the physics (contextual) questions; at least three of the 10 students have retained VHL–II concepts. S4 and S8 also retained VHL–I concepts.

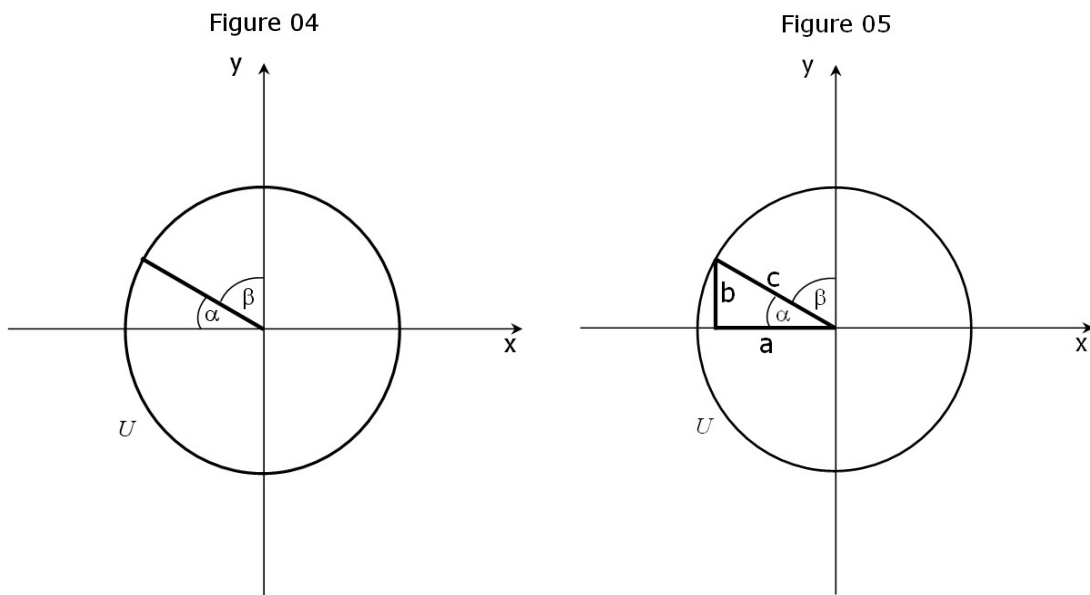

Figure 4.20 Figures 04 and 05 of the Second Interview

S9 also correctly solved Question 02, but was not sure of his results. Therefore, the questions pertaining to Figure 04 were asked in which he correctly responded to all questions. When asked “What quantity in Question 02 does ‘ α ’ represent?” he immediately went back to Question 02 and confirmed all of his calculations. When asked

“Did anything at all about Figure 04 prompt you to solve Question 02? If so, what?,” he said that when he looked at it as a triangle the components gave him an x and y , so he thought back to the unit circle and when he saw ‘ α ’ by itself he could find what he needed. He then correctly answered the questions pertaining to Figure 05. Therefore, S9 has retained VHL–I and –II concepts; however, the mathematical (abstract) Figure 04 prompted him to confirm his answers to the physics (conceptual) question.

S1 and S7 were unable to solve Question 02; S1 had difficulty with the angle as well as the conversion from degrees to radians and S7 had difficulty with the placement of the point on the unit circle (see Figure 4.19). When the interviewer directed S1 to the equation sheet, she was able to successfully complete Question 02 as well as the questions pertaining to Figure 04. The allotted interview time expired and therefore we could not proceed to Figure 05. Thus, S1 has retained VHL–I concepts. S7 was able to successfully complete Question 02 after she answered the following two prompts: “Where is the initial position?” and “In what direction is the mass moving?” Once she responded to these prompts, she was able to correctly solve Question 02 as well as all questions pertaining to Figures 04 and 05. Therefore, after some minor prompting these two students were able to successfully transfer VHL–I and –II concepts to the physics (contextual) question.

S3 incorrectly solved Question 02. When presented with the questions pertaining to Figure 04, she retained VHL–I knowledge and correctly answered the questions. She also correctly answered the first three questions pertaining to Figure 05 which asked her to solve for the variables of Figure 05. When she was asked “What physical quantity in Question 02 does ‘ α ’ represent?” she immediately said the radius. After some additional

thinking, she changed her answer to “maybe not quite as long as the radius.” She then went back to Question 02 and correctly solved the question. When asked “What about Figure 05 prompted you to go back to Question 02?” she said “at first I thought that, what a is in Figure 05, was equal to the radius, then from the picture I could kinda see that it wasn’t, and that c was actually equal to the radius, so c equaled one where I was doing the problem with a equal one before.” Therefore, she transferred her VHL–I and –II knowledge to the physics (contextual) question when prompted by Figure 05.

S2, S5, and S10 were not able to correctly solve Question 02. They were able to correctly answer questions pertaining to Figure 04 but that did not prompt them to solve Question 02. When presented with questions pertaining to Figure 05, S10 was able to correctly answer all questions but did not have time to go back to Question 02. S2 and S5 both could not respond to the question: “What is ‘ a ’ in terms of ‘ c ’ and ‘ β ’?” Therefore, S5 has retained VHL–I knowledge but was not able to neither retain nor transfer VHL–II concepts. Also, S2 and S5 were able to retain VHL–I knowledge when asked the questions pertaining to Figure 04; however, they were not able to retain VHL–I knowledge when asked the questions pertaining to Figure 05 and not able to retain nor transfer VHL–II concepts.

As indicated by the results of the Second Interview Question 02, eight out of the 10 students retained VHL–I (geometric level) concepts and the other two showed some retention of those concepts although they had difficulty with the questions pertaining to Figure 05. The majority of the students correctly applied the cosine and sine functions to various right triangles. Also, three of the 10 students retained VHL–II (unit circle level) concepts without prompting; four of the 10 students transferred VHL–II trigonometry

concepts and correctly solved the physics (contextual) question when prompted with various protocol questions and figures; three of the 10 students did not retain nor transfer VHL–II concepts and were not prompted by the Figures (04 or 05).

4.2.3. Third Set of Interviews

The third set of interviews consisted of VHL–II (unit circle level) and –III (function level) questions in the context of vibrations and waves. The interviews were conducted after instruction and testing on the concepts of vibrations and waves.

Modifications to Third Interview Protocol after Pilot Interviews

The first modification was adding “Once you answer a certain part of Question 01, I have some additional questions for you before you move on to the next part.” Students during the pilot interviews immediately began solving remaining parts of Question 01. In order for the interviewer to provide abstract Figures and the relevant abstract questions that were similar to the physics question; this comment was added to the protocol.

Also, the wording of some of the questions was altered to make it more understandable to the students. For instance a question that initially asked: “What can you associate the 0.4 in the equation $x = 0.4 \cos (6.28 t)$ with in the reference circle?” was modified to “In the equation $x = 0.4 \cos (6.28 t)$, what can you associate the 0.4 with in the reference circle?” This question and a similar question but asking about the other number (6.28 instead of 0.4) was modified to create less confusion for the interviewees

which was observed during the pilot interviews. Similarly, to avoid further difficulty some of the figures were re-labeled.

Question 01 of the Third Interview

<u>Question 01</u>
A 0.50-kg mass vibrates according to the equation $x = 0.40 \cos(6.28 t)$, where x is in meters, and t in seconds.
a. Determine the amplitude 'A'.
b. Determine the angular frequency ' ω '.
c. What are the units of the product of whatever is inside the ' $\cos(\dots)$ ' ?
d. What is the displacement at $t = 0.3$ seconds?
e. Graph the equation of x vs. t showing correct amplitude 'A' and period 'T'.
f. Represent the equation $x = 0.40 \cos(6.28 t)$ in terms of a reference circle?

Figure 4.21 Question 01 of the Third Interview

Question 01 of the third set of interviews consists of VHL–II (unit circle level) and –III (function level) knowledge in the context of vibrations and waves.

Part (a) required students to solve for the amplitude of the given function. All students except for one (S2) were able to provide a correct response to part (a) without prompting. When S2 was presented with Equation 01: $x = a \cos(bt)$, he was not able to provide correct responses for all amplitude protocol questions. When Equation 01 was presented to all students, nine out of the 10 students were able to provide correct responses to the following question: “What is the amplitude?” Four of out of the 10 students provided the correct response to the following question: “What is the maximum value ' $\cos(bt)$ ' of an angle can have?” Therefore, some students may be prompted to

transfer their knowledge from an abstract equation (Equation 01) to the physics (contextual) question. Three out of the 10 students provided correct responses to the following question: “What is the maximum value ‘ x ’ can have?” Therefore, we also believe that some students may be prompted to transfer their knowledge from the abstract equation to the physics question; however, we do not have any evidence of transfer.

Part (b) required students to solve for the angular frequency of the given function. All students except for two (S2 and S6) were able to provide a correct response to part (b) without prompting. When S2 and S6 were presented with Equation 01, they were not able to provide correct responses for all the questions pertaining to angular frequency. When Equation 01 was presented to all students, eight out of the 10 students were able to provide correct responses to the following question: “What does ‘ b ’ represent?” S2 responded by saying an angle and S6 responded with the period. However, only one out of the 10 students provided the correct response to the following question: “What are the units of ‘ b ’?” Therefore, we have little confidence that this question would prompt students to transfer their knowledge from an abstract equation (Equation 01) to the physics (contextual) question. The common misconceptions students had with this question were that the units of ‘ b ’ are seconds, Hertz, and meters per second. Four out of the 10 students provided correct responses to the following question: “Is there a relationship between ‘ b ’ and the angular frequency ‘ ω ’?” Therefore, some students may be prompted to transfer their knowledge from the abstract equation to the physics question; however, we have no evidence of transfer.

Part (c) required students to solve for the units of the product of whatever is inside the ‘ $\cos(\dots)$ ’ of the given function. Three students (S1, S2, and S6) were able to provide

a correct response to part (c) without prompting. However, when S2 and S6 were presented with Equation 01, they were unable to provide correct responses for questions pertaining to the angular frequency. S2 simply said “I don’t know” and S6 said “radians per second.” Therefore, these protocol questions resulted in negative transfer for these two students since they correctly answered the physics question, but changed their answers when asked questions pertaining to Equation 01. Two students (S3 and S7) correctly answered the first question pertaining to Equation 01: “What are the units of ‘ b ’?” They immediately went back to Question 01 and provided the correct answer. Therefore for these two students, the protocol questions resulted in positive transfer from an abstract trigonometric equation to a physics context. The remaining five students were inconsistent with their responses to the protocol questions. Therefore, questions pertaining to the abstract equation, Equation 01, may have negative and positive effects on transfer of learning from trigonometry to physics.

Part (d) required students to solve for the displacement at a certain instant in time of the given function. Four students (S1, S3, S7, and S10) were able to provide a correct response to part (d) and all questions pertaining to the displacement of Equation 01 at a certain instant in time without prompting. The remaining students (S2, S4, S5, S6, S8, and S9) correctly solved for the displacement, however their calculators were in degree mode and therefore all arrived at an incorrect value for the displacement. When asked the displacement protocol question: “What does ‘ x ’ represent in the equation $x = 0.4 \cos(6.28 t)$?” they all said displacement except for S2 (no time remaining) and S6 (no response).

Part (e) required students to graph the given equation showing correct amplitude ‘A’ and period ‘T’ of the given function. Four students (S3, S8, S9, and S10) were able to provide a graph with the correct amplitude but not the correct period. S9 correctly solved for the period, but was not convinced with his answer. S10 correctly solved for the period when prompted by the protocol question: “What is the maximum value of ‘x’?” – however, S10 only indicated the period to be one-half a cycle on her graph. Other than S10 being prompted by the protocol question, all other nine students were not prompted by any of the questions pertaining to the graph of ‘ x vs. t ’. Therefore, the majority of students did not retain nor did they transfer their trigonometry knowledge to the physics (contextual) question.

Part (f) required students to graph the given equation in terms of a reference circle – comparing simple harmonic motion to an object rotating in a circle. Three students (S1, S8, and S10) had time to begin their solution to part (f), but did not make much progress. The remaining seven students did not have time to begin part (f); therefore this question will not be discussed. No significant results were observed from the three students that had time to begin expressing the given equation in terms of a reference circle.

As indicated by the results of the Third Interview Question 01, a majority of the students retained VHL–III (function level) concepts of amplitude and angular frequency of a given function. Many of the students had difficulty with determining the period of a given function and students also have difficulty correctly representing the amplitude of a given function on a graph, i.e. some believe the peak-to-peak distance is the amplitude and others believe the amplitude is one-fourth the peak-to-peak distance. Also, students

are not able to retain unit circle representations of a given functions; however, due to a very brief description of the reference circle in their physics textbook and possible lack of instruction on the reference circle during lecture, students may not be expected to transfer unit circle (reference circle) representations to given physical (contextual) functions.

Question 02 of the Third Interview

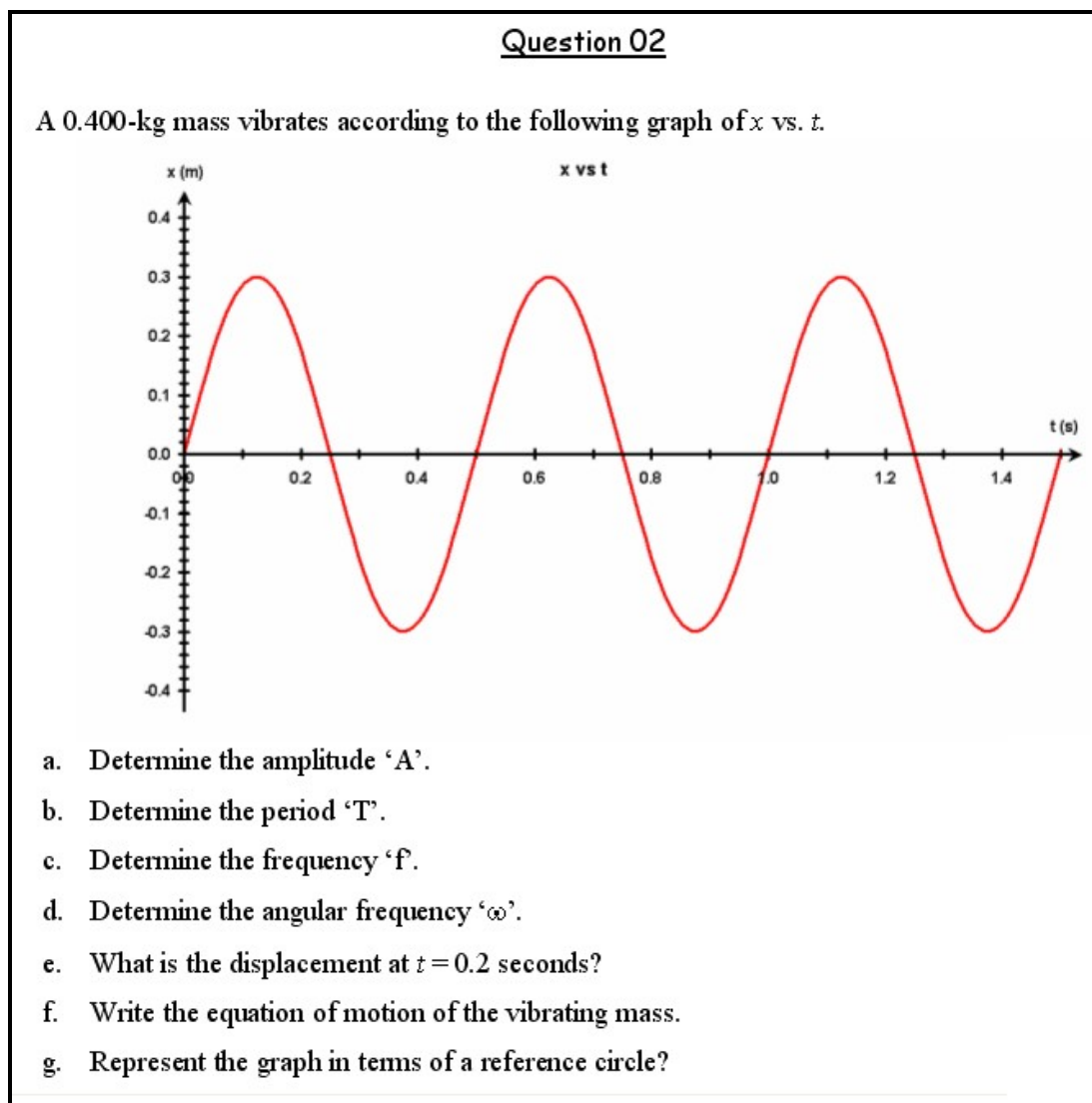

Figure 4.22 Question 02 parts (a) through (g) in the Third Interview

The second question of the Third Interview consists of VHL–II (unit circle level) and –III (function level) knowledge in the context of vibrations and waves.

Part (a) required students to determine the amplitude of the given graph. All students except for three (S2, S3, and S4) were able to provide a correct response to part (a) without the prompting question: “What is the maximum value ‘ x ’ can have?” When S2 was asked the prompt, he correctly answered the question. S3 was also prompted by the same question; however she second–guessed herself and said either 0.3 or 0.6 for the amplitude of the graph. S4 did not change his mind after the prompt.

Part (b) required students to determine the period of the given graph. All students except for one (S10) were able to provide a correct response to part (b) without the prompting question: “Over what duration of time does the graph repeat itself?” S10 did not change her mind after the prompt; however, S2 changed his mind after the prompt and therefore demonstrated negative transfer.

Part (c) required students to solve for the frequency of the given graph. Three students (S2, S6, and S10) were not able to provide a correct response to part (c) prior to the prompting question: “What is the relationship between the period ‘ T ’ and the frequency ‘ f ?’” When S2 and S10 were presented with the prompt, they were able to correctly answer the question. S6 responded before the prompt by saying that he is beginning to confuse the period and the frequency and therefore incorrectly answered Question 02 part (c) as well as the prompt – negative transfer.

Part (d) required students to solve for the angular frequency of the given graph. Three students (S2, S6, and S8) were not able to provide a correct response to part (d) prior to the prompting question: “What is the relationship between the angular frequency

‘ ω ’ and period ‘T’ or frequency ‘f?’” S2 and S6 utilized the correct method for the solution; however, they used an incorrect frequency calculation. S2 used amplitude divided by the period and S6 used the number of total cycles shown in the graph multiplied by a factor of two. S10 correctly solved Question 02 part (d), but at this point realized after looking at the units for angular frequency that she did not correctly solve parts (b) and (c) and therefore went back to those parts and corrected her solutions. Therefore, asking the questions in the order of first solving for the period, then the frequency, and then the angular frequency prompted her to correct her previous solutions – positive transfer. Once the prompt was asked, S5 was not able to provide a response even though he correctly solved part (d).

Part (e) required students to determine the displacement at a certain instant in time of the given graph. Three students (S2, S4, and S9) were not able to provide a correct response to part (e) prior to the prompting question: “According to the graph given in the question, what is the displacement?” After the prompt was asked, S2, S4, and S9 applied the correct method to solve for the displacement from the given graph; however S2 did not properly measure the displacement. S3 answered part (e) by calculation as opposed to looking at the graph. When she realized her calculation did not match the graph, she immediately changed the amplitude to the correct value (0.3 instead of 0.6) and correctly solved for the displacement – positive transfer.

Part (f) required students to write the equation of motion of the given graph. Two students (S2 and S6) did not have time to complete part (f). Of the remaining eight students, all but one (S4) were able to correctly write the equation of motion from the given graph. S4 continued to use the incorrect amplitude (0.6).

Part (g) required students to represent the given graph in terms of a reference circle – comparing simple harmonic motion to an object rotating in a circle. A majority of the students (except S2 and S6) had time to begin their solution to part (g), but did not make much progress (possibly due to the lack of instruction or lack of knowledge of a ‘reference circle’) – therefore this question will not be discussed.

Part (h) of Question 02 (See Figure 4.23) required students to write a new equation of motion of a (sine) graph shifted to a new position (cosine graph). Five (S1, S3, S7, S8, and S9) of the ten students were able to provide the correct response to part (h) and one student (S2) did not have time to complete the part. S6 did not provide a solution, however he realized the graph has a phase shift. S10 correctly wrote the equation, however she used ‘0’ instead of the time (t) variable – possibly due to the point on the graph shifted from some time (t) to a time when $t = 0$, however, we do not have evidence of this being the reason.

- h. Suppose the graph (**Graph H1**) is shifted so the point (**P₁**) is at the origin (see **Graph H2**), what is the new equation of motion representing the graph (**Graph H2**)?

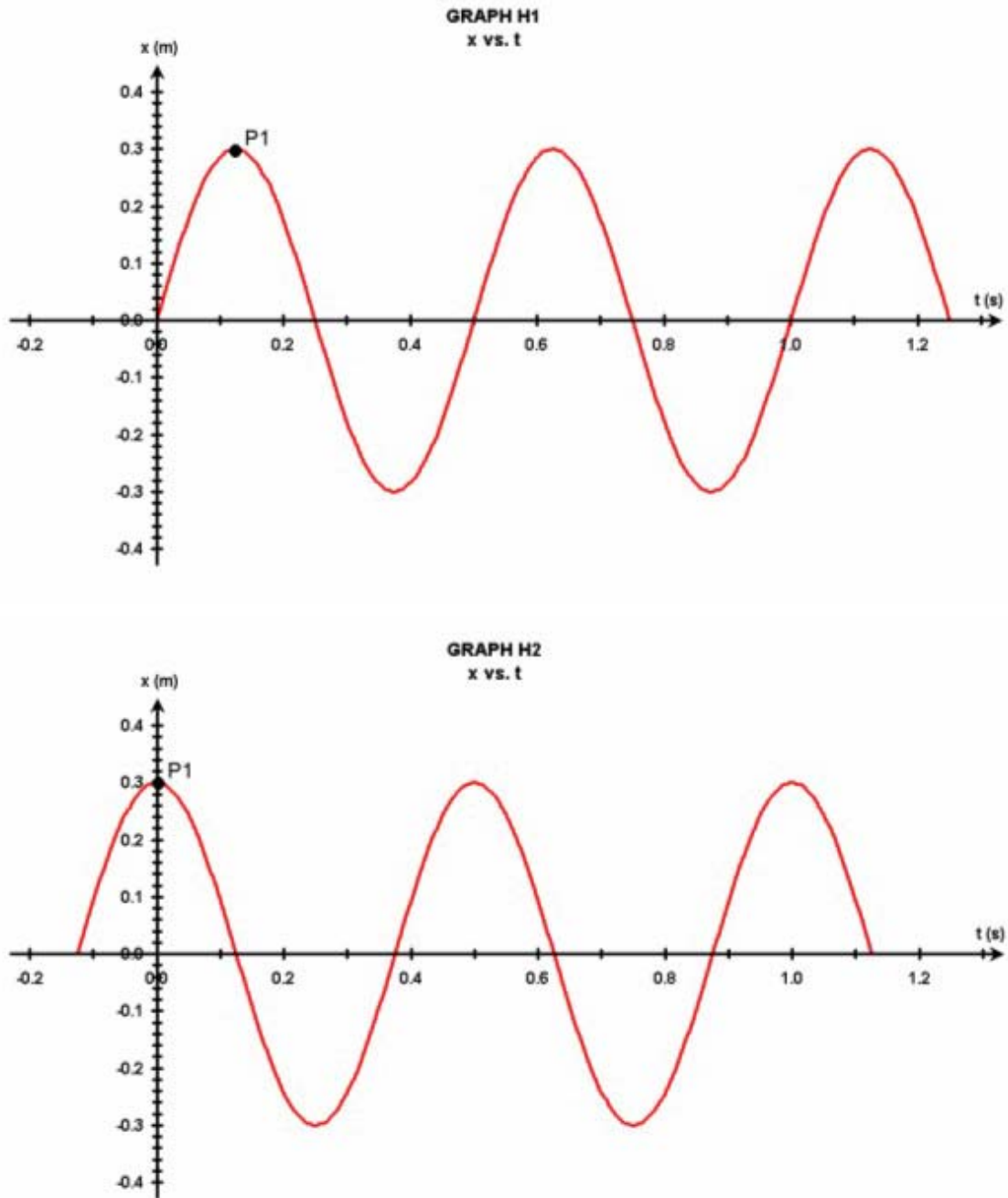

Figure 4.23 Question 02 - part (h) in the Third Interview

As indicated by the results of the Third Interview Question 02, a majority of the students retained VHL–III (function level) concepts of amplitude, period, frequency, angular frequency, and displacement of a given graph. Students are not able to retain unit circle representations of a given functions; however, due to a very brief description of the reference circle in their physics textbook and possible lack of instruction on the reference circle during lecture, students may not be expected to transfer unit circle (reference circle) representations to given physical (contextual) functions.

The results of the Third Interview Question 02 also indicate that students retain and transfer a greater amount of VHL–III concepts when provided with a graph and asked to determine various features of the graph as well as write the function of the graph – as opposed to the Third Interview Question 01 where they were not as successful in determining various features of a given function and then graphically representing the function. However, something to consider is question order effects. Students may have been influenced by first solving a question with a given function followed by a question with a given graph, but we have no evidence of the reverse situation in which students would be first provided with a given graph and therefore cannot make any conclusions.

Summary of Interview Results

The interviews provided insights into the level of trigonometry concepts (VHL) that students transfer in the context of physics problems. They also provide us insights into the extent to which students need to be prompted through the use of abstract (trigonometry) questions to productively transfer these concepts to solve contextualized (physics) problems. VHL–I concepts were more frequently retained than VHL’s II and

III; thus, there were very few situations in which students transferred VHL–I concepts to the physics (contextual) question. However, students had much more difficulty with VHL–II concepts as previously indicated by the surveys. Therefore, students did not retain these concepts as much as they retained VHL–I concepts, which is consistent with the hierarchy of VHL’s.

Evidence of transfer was observed with VHL–II concepts; which indicates the abstract figures and the questions based on those figures do prompt students to transfer their knowledge of trigonometry to physics. Students retained a greater amount of VHL–III concepts when provided a graph as opposed to when they were given a function. Few students were able to represent VHL–III concepts in terms of a reference circle, most probably due to the lack of instruction and significance within their physics textbook. Post–interview discussions indicate that students do see a connection between the reference circle and the given graphs or functions of VHL–III concepts. However, the students did not see these connections by themselves – but most agreed that the reference circle representation may aid in their retention of VHL–III concepts.

CHAPTER 5

CONCLUSION

5.1. RESPONSE TO RESEARCH QUESTIONS

Research Question # 1: What concepts have the students learned in the trigonometry courses?

The distribution of trigonometry course grades indicates that almost all students learned trigonometry satisfactorily in the course, assuming the course grades are a valid measure of student learning. However, the non-significant correlation between the on-line homework assignments and course grades indicate that the on-line homework assignments cannot be used to measure student learning in trigonometry in the same way as course grades can. The non-significant correlation may be explained by the fact that evaluation measures other than the on-line homework were involved in computing the course grade – class participation, quizzes, and on-line homework accounted for only 29% of the total course grade. The on-line assignments also used the maximum scores divided by the number of attempts in all calculations. However, these are only the maximum values and may not truly reflect students' performance – some students may have earned the maximum score several times, i.e. practiced several additional times.

Although the on-line homework grades are not a valid measure of student learning in trigonometry, they were the only measure that we had available that allowed us to assess student learning in trigonometry at different Van Hiele Levels. Students' maximum scores divided by the number of attempts were used as a measure of performance for each homework assignment. These values were averaged over

assignments pertaining to each of the three VHL's. Statistically significant results indicate that students perform significantly poorly in VHL-III questions that required a functional understanding of trigonometry compared to VHL-I and -II questions that required understanding of the geometrical and unit circle representations in trigonometry.

There was no statistically significant difference between student performance on VHL-I and VHL-II assignments, both of which were significantly superior to their performance on VHL-III assignments, indicating that students appear to have achieved significantly better on the geometrical and unit circle representations than on functional representations in trigonometry.

Research Question # 2: What knowledge do the students retain from their trigonometry course when they begin their physics course?

Results based on the proportion of students that correctly answered questions in each of the Van Hiele Levels (VHL's) on the pre-instruction survey mathematics (abstract) questions show that students statistically have more difficulty with VHL-II questions. The first and second interview results also indicate that students retain VHL-I concepts more frequently than VHL-II; i.e. the Pythagorean Theorem and the sine, cosine, and tangent concepts more than the unit circle concepts. The majority of students do retain VHL-I knowledge as indicated by the survey and interview assessments of transfer.

Taking into account the fact that VHL's have a progressively increasing degree of conceptual difficulty, the results are anomalous in that a smaller proportion of students answered the VHL-II questions correctly than VHL-III questions on the pre-instruction survey. Comparing these results with that for student learning in the trigonometry course

for the three VHL's, we find that although students appear to have learned the concepts in VHL's I and II about equally well, they appear to have much greater difficulty in retaining what they have learned in VHL-II than in VHL-I. This result also appears to indicate that the unit circle concept in trigonometry is particularly difficult for students to retain after they have completed the course. Interview results from the second interview also show that a very small number of students demonstrate retention and transfer of VHL-II concepts without the provided prompts.

A majority of students retain the VHL-III concepts of amplitude and angular frequency of a given function or a given graph. However, results show that students have difficulty correctly representing the amplitude of a given function on a graph. Students also have difficulty with determining the period of a given function, although most were able to correctly respond to the period of a given graph. Students perform better in determining the displacement of a given graph at a certain instant in time than they do with a given function. However, we believe this result is due to the fact that many students did not check whether their calculator is in the proper mode, i.e. degrees or radians.

A distribution of the average total score on the pre-instruction survey versus the number of semesters the students completed the trigonometry course prior to taking GP1 indicate that the longer the time period between the courses, the less likely they are to perform well on the pre-instruction survey. A distribution of the average total mathematics (abstract) question score in each VHL on the pre-instruction survey versus the number of semesters the students completed the trigonometry course prior to taking GP1 also indicates that students have greater difficulty in retaining VHL-II concepts than

VHL-I. These data appear to be consistent with conventional wisdom among educators that students retain less content as time progresses.

Further assessment of student retention of trigonometric concepts show the on-line trigonometry homework assignment scores for each VHL and the corresponding pre-instruction survey mathematics (abstract) questions for each VHL do not statistically correlate. These results appear to indicate that student performance on the on-line homework assignments in trigonometry is not a good predictor of student retention in each of the VHL's; however it appears to be a good predictor of their overall mathematical ability as they begin the physics course. Trigonometry course grades statistically correlate with the pre-instruction survey mathematics (abstract) questions, therefore the course grades in trigonometry are a good predictor of student retention of trigonometry knowledge as measured by the pre-instruction survey.

Research Question # 3: How consistently do students use their understanding developed in trigonometry courses when encountering these ideas in new contexts? More specifically, is it easier for students to transfer certain mathematical concepts/representations and skills than others to a given physical context?

Traditional models of transfer (Bassok, 1990; Chen and Daehler, 1989; Adams et al., 1988; Brown and Kane, 1988; Novick, 1988; Nisbett et al., 1987; Perfetto et al., 1983; Reed et al., 1974; Wertheimer, 1959; Thorndike and Woodworth, 1901a) focus on whether or not students demonstrate transfer of a concept that is pre-defined by the researcher as assessed using a static, 'one-shot' process. Contemporary models of transfer (Lobato, 2003; Bransford and Schwartz, 1999; Lobato, 1996; Greeno et al.,

1993) account for aspects the traditional models neglect (i.e. socio-cultural, available resources during the initial learning situation) by viewing transfer from the students' point of view – an active, dynamic process. We address this research question from both the traditional perspective of transfer as well as the more contemporary perspectives such as Bransford and Schwartz's (1999) 'preparation for future learning' perspective and Lobato's (2003) 'actor-oriented transfer' perspective.

Traditional Perspective. The traditional perspective of transfer was used to assess transfer of learning by using the survey data. The relevant (first six) on-line trigonometry assignments, in terms of VHL's, average maximum score divided by the number of attempts was correlated with the pre- and post-instruction survey physics (contextual) question total scores. Results show that there are no statistically significant correlations between the first six on-line trigonometry assignments and the total score on the pre- and post-instruction survey physics (contextual) questions.

Results of on-line trigonometry assignment score correlations with the scores on the pre-instruction survey physics (contextual) questions indicate that only one assignment (VHL-II) is statistically significant. However, the other assignments are not statistically significant; therefore there is no clear evidence that transfer of learning may be measured by looking at the individual on-line trigonometry assignments and the pre-instruction survey physics (contextual) questions. Results also show that there are no statistically significant correlations for each of the VHL's of the on-line trigonometry assignments and the surveys' physics questions. Results of the trigonometry course grade correlations with the scores on the pre- and post-instruction survey physics

(contextual) questions indicate that the post-instruction survey physics questions is statistically significant. The trigonometry course grades also statistically correlate with the pre-instruction survey physics geometric (VHL-I) questions as well as the post-instruction survey physics function (VHL-III) questions. Therefore, there is clear evidence that transfer of learning may be measured by the trigonometry course grades and certain VHL's of the pre- and post-instruction survey physics (contextual) questions; however the evidence is not consistent between VHL's.

Therefore, the conclusion from the traditional perspective of transfer is that students do not transfer their learning from trigonometry to physics when looking at their on-line trigonometry assignments and the pre- and post-instruction surveys physics (contextual) questions. Also, the trigonometry course grades and the pre- and post-instruction survey physics (contextual) questions provide some evidence of transfer, however the evidence is not consistent between surveys not VHL's.

Preparation for Future Learning Perspective. Bransford and Schwartz (1999) provide a contemporary perspective of transfer called “preparation for future learning” (PFL) where the focus is on how students *learn* to solve problems in the new situations. This perspective was used to assess transfer of learning through the survey and interview data. The correlation between the on-line trigonometry homework assignments and each students' gain in scores (i.e. difference between post-instruction score and pre-instruction score) on the physics (contextual) survey questions is not statistically significant. Therefore, from this view of the PFL perspective, students do not transfer

their learning through the course of physics instruction when assessed by on-line trigonometry homework and the gain on the survey physics questions.

Results also show there is no statistically significant correlation between overall pre-instruction survey mathematics (abstract) questions and the gain in survey physics (contextual) questions; thus, this view of the PFL learning perspective will not measure transfer of learning. The on-line trigonometry assignments and the gain in survey physics question scores were categorized into the respective Van Hiele Levels (VHL's) and correlated. Results indicate that only a statistically significant positive correlation exists between the on-line trigonometry assignments of VHL-I and the gain in the survey physics questions. VHL-III actually has a negative correlation – a possible reason for this is the fact that VHL-III is the highest level in which students think at in the hierarchy of levels. Also, the questions pertaining to phase shifts (VHL-III) asked on the pre- and post-instruction surveys may have an effect on student performance – phase shifts were not discussed in the *General Physics* course.

Results show no statistically significant positive correlation between student performances on questions in any of the VHL's when looking at the pre-instruction survey mathematics (abstract) questions versus the pre- vs. post-survey gains in the physics (contextual) questions. The result is particularly surprising for VHL-III questions, where the correlation is statistically significant but negative! indicating negative transfer. We speculate that the lack of physics instruction on the concept of phase shifts or differences between terminology used in physics and mathematics may be the factor that is causing students not to transfer some trigonometry concepts to physics, although they are successfully able to transfer other concepts.

Another albeit cruder method to analyze transfer from the PFL perspectives is a correlation between the *Trigonometry* course grades and the *General Physics 1* (GP1) course grades; where the assumption is that the GP1 course grades are a measure of learning in the course. This method is ‘cruder’ than others because it does not allow us to differentiate between student performance at different Van Hiele Levels, and also because overall course grades are dependent of several factors that we cannot control for. However, we find that the correlation coefficient between the Trigonometry course is statistically significant; therefore, as per the PFL model of transfer, students are able to transfer their knowledge from the trigonometry course to the algebra-based physics course. Yet when we calculate the correlation coefficient between the on-line trigonometry homework scores and the pre-instruction survey scores, no evidence of transfer was found. However, in light of our earlier result (Research Question # 1) regarding the non-significant correlation between on-line assignment grades and trigonometry course grades, this result is not surprising and reflects more on the inadequacy of using performance on on-line assignments to assess student learning than on the lack of transfer of learning.

Actor-Oriented Transfer Perspective. Lobato (2003) conceives transfer as the “personal construction of similarities between activities” – how the actors (i.e. learners) see situations as similar. She implies that we should extend transfer theory beyond the traditional models of transfer where researchers pre-define the concept which they hope one would transfer and adopt a more student-centered perspective to have a better

understanding of the factors that facilitate transfer. This perspective was used to assess transfer of learning through the survey and interview data.

Results show statistically significant correlations between pre-instruction survey mathematics (abstract) questions with the pre-instruction survey physics (contextual) questions and the post-instruction survey mathematics questions with the post-instruction survey physics questions. When these data were correlated in specific VHL's, results indicate that VHL-I and -III questions also had statistically significant correlations; therefore, it appears that students are able to dynamically transfer their knowledge from one question to another within the pre- and post-instruction surveys for VHL's I and III. However, the abstract and contextual VHL-II questions do not correlate with each other. This result is consistent with our earlier results (Research Question #2) that students have particular difficulty in retaining VHL-II concepts pertaining to the unit circle. Therefore it is likely that students on the first day of recitation (when the pre-instruction surveys were administered) may not have been able to recall the equation for relating the arc length, radius, and angle which is needed in order to successfully solve two VHL-II questions. These same VHL-II questions do have a statistically significant correlation on the post-instruction survey. Upon further inspection of the VHL-II questions by individual versions, version 3 – in which students were presented with a series of abstract mathematics questions followed by a series of related contextual physics questions – was the only version in which there were negative correlations for both the pre- and post-instruction surveys. Therefore, version 3 is not conducive to transfer of learning at VHL-II. We speculate that presenting the math questions in a separate set albeit before a set of physics questions prevents students from

seeing the connections between the math and physics questions and therefore inhibits their “personal constructions of similarity.”

Statistically significant correlations were also observed between the pre- and post-instruction survey gains on the mathematics (abstract) and physics (contextual) questions. These correlations were statistically significant for VHL-III but not for VHL-I and -II questions. In fact, there was once again a negative correlation for VHL-II questions. Thus, actor-oriented transfer does not occur uniformly across all VHL's. Curiously, VHL-III questions appear to be more conducive to actor-oriented transfer. We speculate that the reason for the increased likelihood of actor-oriented transfer at VHL-III is probably because VHL-III questions clearly require the use of trigonometric functions, which students can directly associate with their mathematical knowledge. Where as in case of VHL-I and VHL-II questions, the mathematical concepts appear to be more ‘hidden’ to the students or rather the physics of the problem appears to obscure their ability to see the connection with the underlying mathematical concepts.

Interview results indicate that students may exhibit both positive as well as negative transfer from the actor-oriented transfer perspective. For instance, when solving the VHL-III questions, several students exhibited negative transfer when they were able to solve the physics (contextual) question followed by the trigonometry (abstract) interview questions, but then changed their correct response on the physics question to an incorrect response – they were not able to transfer that knowledge back to the physics question. These students did not see the two problems “as being similar” when provided with the abstract trigonometry questions; thus, they were not able to transfer their trigonometry knowledge to the contextual physics question. On the other

hand, some students were not able to solve the physics question and then correctly responded to the trigonometry questions, and later without any additional prompts or comments, they immediately went back to the physics question and correctly solved that question. These students perceived the two problems “as similar” and thus positively transferred their trigonometry (abstract) concepts to a physics (contextual) question. For instance, almost half the students transferred their trigonometry knowledge to the given rotational motion physics question (VHL–II) when prompted with the various protocol questions as per the ‘preparation for future learning’ and the ‘actor-oriented’ perspectives.

Results also indicate that students did not retain nor did they transfer their trigonometry knowledge to the physics (contextual) question in the context of graphing a function; therefore, the prompts that were provided did not appear to aid in student transfer. The third interview data show that students retain and transfer a greater amount of VHL–III concepts when provided with a graph and asked to determine various features of the graph as well as in writing the equation of the graph before being expected to use the graph of the function in a physics question.

Final Conclusions to Research Question # 3. As indicated by the discussion above, transfer of learning from trigonometry to physics may not be observed by some of the traditional and contemporary perspectives. From the traditional perspectives of transfer assessment, inconsistent evidence of transfer from trigonometry to physics was observed between surveys and between VHL’s. However, when a variety of potential transfer situations are accounted for from the contemporary perspectives of transfer assessment,

evidence was found of transfer of learning from trigonometry to physics. However, transfer does not occur uniformly across all VHL's from either the traditional or contemporary perspective.

5.2. RECOMMENDATIONS FOR FUTURE RESEARCH

The purpose of this research study was to examine student learning, retention, and transfer from trigonometry to physics. As with most research, this study not only answered the questions it posed, but also raised several more interesting questions. Future possibilities include investigating the question order effects on the survey in more detail and investigating conceptual understanding in trigonometry to possibly confirm the Van Hiele Levels for trigonometry. Results indicate that students do not perform as well with unit circle concepts than with function concepts. Thus, the hierarchy of levels needs to be researched. Controlling the order in which students complete the survey questions would provide a deeper understanding of possible question order effects. Question order effects may also have been present during the interviews based on the fact that students performed better on the second interview question during the third set of interviews where they progressed through the question from a given graph to a function as opposed to the first question when they progressed from a given function to a graph.

As in many research studies, student explanations often hold a large amount of information and the responses recorded in this research falls into this category. There was more information than could be analyzed during the course of this study. Future areas of analysis may include looking for consistency in student reasoning, rather than

only their level of mathematical thinking. In general, additional research may be done in understanding the underlying cognitive mechanism that triggers students to transfer their trigonometry knowledge to a physics context.

Survey data may also be further analyzed to investigate whether or not specific versions increase dynamic intra-survey transfer between abstract and contextual questions. Methods in determining the validity of the surveys may provide beneficial results and the possibility that the survey can be used to measure students' mathematical thinking prior to and after physics instruction, as well as a gauge to their ability to transfer their mathematical understanding to physics. Further analysis is needed to determine whether the surveys are a good predictor of student performance in the algebra/trigonometry-based physics course. One additional recommendation for future research is in broadening the administration of surveys to students in high school to determine whether or not transfer from trigonometry to physics occurs in high school as well.

5.3. IMPLICATIONS FOR INSTRUCTION

A number of studies converged on the conclusion that transfer is enhanced by helping students see potential implications of what they are learning (Anderson et al., 1996). Several students were able to successfully solve a physics displacement question but were not able to successfully solve a similar trigonometry question. When the abstract figure was modified to include arrows (vectors) instead of solid lines, several students were immediately prompted to solve the abstract question. This may be considered an example in which trigonometry teachers may improve the necessary cognitive tools to

trigger the transfer of knowledge between various contexts by comparing and contrasting similar abstract and contextual questions.

The study also has implications for physics instruction. It appears that having students solve an abstract mathematics problem just before they are asked to solve a physics problem that uses the same mathematical concept may help cue students to the mathematical concepts that underlie the physics problem. Thus for instance, in tutorial or problem-solving sessions, it may help to ask students to solve an abstract mathematical problem before embedding the math into a physics context. Another implication for instruction comes from discussions with interviewees after the final interview. Most students were not able to begin a solution to the reference circle questions while solving functions; however, after the interviews when the students wanted to discuss the interview questions, several students were able to see the connection between the reference circle and a given graph or function. Several of these students commented that if this connection may have been more established, they believed it would have positive impacts on retention of these concepts and transfer to various problem scenarios.

This study has not attempted significant research of question order effects; however, it does suggest that assessments of learning and transfer should account for the effects of question order. Although only a small number of questions between various versions showed statistically significant order effects, caution should be considered when creating multiple versions by rearranging questions on surveys, exams, or homework assignments.

As mentioned in the previous section, students do not perform as well with unit circle concepts when compared to geometric or function concepts. However, most

trigonometry textbooks present unit circle concepts prior to function concepts. It would be interesting to try action research within a trigonometry course where function concepts are presented prior to the unit circle and then determining whether or not student retention and transfer is affected.

Overall, this study has provided several interesting insights into the level of student knowledge and learning in trigonometry and how they retain and transfer this knowledge to a physics course.

CHAPTER 6

REFERENCES

- Adams, L., Kasserian, J., Yearwood, A., Perfetto, G. A., Bransford, J. D., and Franks, J. J. (1988). The effects of facts versus problem-oriented acquisition. *Memory and Cognition*, **16**, 167-175.
- Anderson, J. R., Reder, L. M., and Simon, H. A. (1996). Situated Learning and Education. *Educational Researcher*, **25**(May), 5-96.
- Barrows, H. S. (1985). *How to Design a Problem-Based Curriculum for the Preclinical Years*. New York, NY: Springer.
- Bassok, M. (1990). Transfer of domain-specific problem-solving procedures. *Journal of Experimental Psychology: Learning*, 522-533.
- Beichner, R. (1994). Testing student interpretation of kinematics graphs. *American Journal of Physics*, **62**, 750-762.
- Bennett, A. G. (2003). Personal Communication: Pilot survey questions and face validity. Manhattan, KS.
- Bjork, R. A., and Richardson-Klavhen, A. (1989). On the puzzling relationship between environment context and human memory. In C. Izawa (Ed.), *Current Issues in Cognitive Processes: The Tulane Flowerree Symposium on Cognition*. Hillsdale, NJ: Erlbaum.
- Bransford, J. D., Brown, A. L., and Cocking, R. R. (Eds.). (1999). *How People Learn: Brain, Mind, Experience, and School*. Washington, DC: National Academy Press.
- Bransford, J. D., and Schwartz, D. (1999). Rethinking transfer: A simple proposal with multiple implications. *Review of Research in Education*, **24**, 61-100.
- Brown, A. L., Bransford, J. D., Ferrara, R. A., and Campione, J. C. (1983). Learning, remembering, and understanding. In J. H. Flavell and E. M. Markman (Eds.),

Handbook of Child Psychology: Vol. 3 Cognitive Development (4th ed.). New York, NY: Wiley. Pp. 78-166

Brown, A. L., and Kane, M. J. (1988). Preschool children can learn to transfer: Learning to learn and learning from example. *Cognitive Psychology*, **20**, 493-523.

Bruer, J. T. (1993). *Schools for thought*. Cambridge, MA: MIT Press.

Bruning, J. L., and Kintz, B. L. (1997). *Computational Handbook of Statistics* (4th ed.). New York, NY: Addison-Wesley Educational Publishers Inc.

Campione, J. C., and Brown, A. L. (1987). Linking dynamic assessment with school achievement. In C. S. Lidz (Ed.), *Dynamic Assessment: An Interactional Approach to Evaluating Learning Potential*. New York, NY: Guilford. Pp. 82-114

Carey, L. M. (2001). *Measuring and Evaluating School Learning* (3rd ed.). Boston, MA: Allyn & Bacon.

Chen, Z., and Daehler, M. W. (1989). Positive and negative transfer in analogical problem solving. *Cognitive Development*, **4**, 327-344.

Cognition and Technology Group at Vanderbilt. (1997). *The Jasper Project: Lessons in Curriculum, Instruction, Assessment, and Professional Development*. Mahwah, NJ: Erlbaum.

Devore, J. L. (2004). *Probability and Statistics for Engineering and the Sciences* (6th ed.). Belmont, CA: Duxbury Publisher.

Doran, R. L. (1980). *Basic Measurement and Evaluation of Science Instruction*. Washington, DC: National Science Teachers Association.

Eich, E. (1985). Context, memory, and integrated item/context imagery. *Journal of Experimental Psychology: Learning, Memory, and Cognition*, **11**, 764-770.

Ericsson, K. A., Krampe, R. T., and Tesch-Romer, C. (1993). The role of deliberate practice in the acquisition of expert performance. *Psychological Review*, **100**, 363-406.

- Freudenthal, H. (1991). *Revisiting mathematics education: China lectures*. Boston, MA: Kluwer Academic Publishers.
- Gagné, R. M., and Gibson, J. J. (Writer) (1947). Research on the recognition of aircraft, *In Motion Picture Training and Research*. Washington, DC: U.S. Government Printing Office.
- Garner, W. R. (1974). *The Processing of Information and Structure*. Potomac, MD: Erlbaum.
- Giancoli, D. C. (1998). *Physics: Principles with Applications* (5th ed.). Upper Saddle River, NJ: Prentice Hall.
- Gibson, J. J., and Gibson, E. J. (1955). Perceptual Learning: Differentiation or enrichment. *Psychological Review*, **62**, 32-51.
- Gick, M. L., and Holyoak, K. J. (1980). Analogical Problem Solving. *Cognitive Psychology*, **12**, 306-355.
- Gick, M. L., and Holyoak, K. J. (1983). Schema induction and analogical transfer. *Cognitive Psychology*, **15**, 1-38.
- Gragg, C. I. (1940). Because wisdom can't be told. *Harvard Alumni Bulletin*, (October 19), 78-84.
- Gray, K. E. (2004). *The Effect of Question Order on Student Responses to Multiple Choice Physics Questions*. Unpublished Thesis, Kansas State University, Manhattan, KS.
- Greeno, J. G., Moore, J. L., and Smith, D. R. (1993). Transfer of situated learning. In D. K. Detterman and R. J. Sternberg (Eds.), *Transfer on Trial: Intelligence, Cognition, and Instruction*. Norwood, NJ: Ablex Publishing Corporation. Pp. 99-167
- Hake, R. R. (1998). Interactive-engagement versus traditional methods: A six-thousand-student survey of mechanics test data for introductory physics courses. *American Journal of Physics*, **66**(1), 64-74.

- Hestenes, D., Wells, M., and Swackhamer, G. (1992). Force concept inventory. *The Physics Teacher*, **30**(March), 159-166.
- Hmelo, C. E. (1995). *Problem-based learning: Development of knowledge and reasoning strategies*. In Proceedings of the Seventeenth Annual Conference of the Cognitive Science Society, Pittsburgh, PA.
- Holyoak, K. J. (1984). Analogical thinking and human intelligence. In R. J. Sternberg (Ed.), *Advances in the Psychology of Human Intelligence* (Vol. 2). Hillsdale, NJ: Erlbaum. Pp. 199-230
- Howell, D. C. (1999). *Fundamental Statistics for the Behavioral Sciences* (4th ed.). Pacific Grove, CA: Brooks/Cole Publishing Company.
- Huffman, D., and Heller, P. (1995). What does the Force Concept Inventory Really Measure? *The Physics Teacher*, **33**, 138-143.
- Judd, C. H. (1908). The relation of special training to general intelligence. *Educational Review*, **36**, 28-42.
- Krathwohl, D. R. (1998). *Methods of Education and Social Science Research: An Integrated Approach* (2nd ed.). New York, NY: Addison-Wesley Educational Publishers, Inc.
- Lobato, J. E. (1996). *Transfer Reconceived: How 'sameness' is produced in mathematical activity*. Unpublished Doctoral Dissertation, University of California, Berkeley, Berkeley, CA.
- Lobato, J. E. (2003). How Design Experiments Can Inform a Rethinking of Transfer and Vice Versa. *Educational Researcher*, **23**(1), 17-20.
- Mazur, E. (1997). *Peer Instruction*. Upper Saddle River, NJ: Prentice Hall.
- National Research Council. (1994). Learning, Remembering, Believing: Enhancing Human Performance. In D. Druckman and R. A. Bjork (Eds.), *Committee on Techniques for the Enhancement of Human Performance, Commission on Behavioral and Social Sciences and Education*. Washington, DC: National Academy Press.

- Newman, D., Griffin, P., and Cole, M. (1989). *The Construction Zone: Working for Cognitive Change in School*. New York, NY: Cambridge University Press.
- Nisbett, R. E., Fong, G. T., and Cheng, P. W. (1987). Teaching reasoning. *Science*, **238**, 625-630.
- Novick, L. R. (1988). Analogical transfer, problem similarity, and expertise. *Journal of Experimental Psychology: Learning, Memory, and Cognition*, **14**, 510-520.
- Novick, L. R., and Holyoak, K. J. (1991). Mathematical problem solving by analogy. *Journal of Experimental Psychology: Learning, Memory, and Cognition*, **17**(3, May), 398-415.
- Perfetto, G. A., Bransford, J. D., and Franks, J. J. (1983). Constraints on access in a problem solving context. *Memory and Cognition*, **11**, 24-31.
- Piaget, J. (1995). *The equilibrium of cognitive structures*. Chicago, IL: University of Chicago Press.
- Polya, G. (1957). *How to Solve It: A New Aspect of Mathematical Method*. Princeton, NJ: Princeton University Press.
- Rebello, N. S., and Zollman, D. A. (2002). The effect of distracters on student performance on the Force Concept Inventory. *American Journal of Physics - PER Supplement*, **70**(7).
- Reed, S. K. (1993). "A schema-based theory of transfer". In D. K. Detterman and R. J. Sternberg (Eds.), *Transfer on Trial: Intelligence, Cognition, and Instruction*. Norwood, NJ: Ablex Publishing Corporation. Pp. 39-67
- Reed, S. K., Ernst, G. W., and Banerji, R. (1974). The role of analogy in transfer between similar problem states. *Cognitive Psychology*, **6**, 436-450.
- Resnick, L. B., and Ford, W. W. (1981). *The Psychology of Mathematics for Instruction*. Hillsdale, NJ: Erlbaum.

- Schecker, H., and Gerdes, J. (1999). Messung von Konzeptualisierungsfähigkeit in der Mechanik - Zur Aussagekraft des Force Concept Inventory. *Zeitschrift für Didaktik der Naturwissenschaften*, 5(1), 75-89.
- Schoenfeld, A. H. (1983). *Problem solving in the mathematics curriculum: A report, recommendation, and an annotated biography*. In Mathematical Association of America Notes, No. 1.
- Schoenfeld, A. H. (1985). *Mathematical Problem Solving*. Orlando, FL: Academic Press.
- Schoenfeld, A. H. (1991). On mathematics as sense-making: An informal attack on the unfortunate divorce of formal and informal mathematics. In J. F. Voss, D. N. Perkins and J. W. Segal (Eds.), *Informal Reasoning and Education*. Hillsdale, NJ: Erlbaum. Pp. 311-343
- Singley, K., and Anderson, J. R. (1989). *The Transfer of Cognitive Skill*. Cambridge, MA: Harvard University Press.
- Skemp, R. R. (1987). *The psychology of learning mathematics*. Hillsdale, NJ: Lawrence Erlbaum Associates.
- Steele, C. (1997). A Threat in the Air: How Stereotypes Shape the Identities of Women and African Americans. *American Psychologists*, 53(6), 613-629.
- Swokowski, E. W., and Cole, J. A. (1999). *Fundamentals of Trigonometry* (9th ed.). Pacific Grove, CA: Brooks/Cole Publishing Company.
- Tate, M. W. (1965). *Statistics in Education and Psychology*. New York, NY: The Macmillan Company.
- Thorndike, E. L. (1913). *Educational Psychology (Vols. 1 and 2)*. New York, NY: Columbia University Press.
- Thorndike, E. L., and Woodworth, R. S. (1901a). The influence of improvement in one mental function upon the efficiency of other functions, Part I. *Psychological Review*, 8, 247-261.

Van Hiele, P. M. (1986). *Structure and insight: a theory of mathematics education*. Orlando, FL: Academic Press.

Wason, P. C., and Johnson-Laird, P. N. (1972). *Psychology of Reasoning: Structure and Content*. Cambridge, MA: Harvard University Press.

Wertheimer, M. (1959). *Productive Thinking*. New York, NY: Harper & Row.

Williams, S. M. (1992). Putting case-based instruction into context: Examples from legal and medical education. *The Journal of the Learning Sciences*, 2(4), 367-427.

APPENDIX A DEMOGRAPHIC AND INTERVIEW REQUEST FORM

Demographic Information

LAST NAME (PRINT ALL CAPS)

FIRST NAME (PRINT ALL CAPS)

Identification Number (I. D. #)

Age: _____ Years

Gender (circle one): Female Male

Status (circle one): Returning Adult Traditional Student

Year in College (circle one): 1st 2nd 3rd 4th 5th 6th or above

Major: _____

GP1 Recitation Section (circle one): 8:30 9:30 11:30 1:30 2:30 3:30

What college mathematics courses
have you taken?

<u>Course</u>	<u>Semester & Year</u>
1.	
2.	
3.	
4.	

What high school and college physics courses
have you taken (including this if repeating)?

<u>Course</u>	<u>Semester & Year</u>
1.	
2.	
3.	
4.	

Fall 2003

Interview Request

NAME: _____ ID# _____

CONTACT INFORMATION:

PHONE # _____ EMAIL: _____

AVAILABLE TIMES:

MONDAYS _____

TUESDAYS _____

WEDNESDAYS _____

THURSDAYS _____

FRIDAYS _____

You will be paid \$30.00 upon completion of all three interviews on topics covered in GP1.
All interview data will be kept completely confidential and anonymous.

Fall 2003

**APPENDIX B
INTERVIEW CONSENT FORMS**

**KANSAS STATE UNIVERSITY
INFORMED CONSENT TEMPLATE**

PROJECT TITLE: _____

PRINCIPAL INVESTIGATOR: CO-INVESTIGATOR(S): _____

CONTACT AND PHONE FOR ANY PROBLEMS/QUESTIONS: _____

IRB CHAIR CONTACT/PHONE INFORMATION: _____

SPONSOR OF PROJECT: _____

PURPOSE OF THE RESEARCH: _____

PROCEDURES OR METHODS TO BE USED: _____

ALTERNATIVE PROCEDURES OR TREATMENTS, IF ANY, THAT MIGHT BE ADVANTAGEOUS TO SUBJECT:

LENGTH OF STUDY: _____

RISKS ANTICIPATED: _____

BENEFITS ANTICIPATED: _____

CONFIDENTIALITY: _____

PARENTAL APPROVAL FOR MINORS: _____

PARTICIPATION: _____

I understand this project is for research and that my participation is completely voluntary, and that if I decide to participate in this study, I may withdraw my consent at any time, and stop participating at any time without explanation, penalty, or loss of benefits, or academic standing to which I may otherwise be entitled.

I also understand that my signature below indicates that I have read this consent form and willingly agree to participate in this study under the terms described, and that my signature acknowledges that I have received a signed and dated copy of this consent form.

Participant Name: _____

Participant Signature: _____

Date: _____

Witness to Signature: (project staff) _____

Date: _____

ADDENDUM TO INFORMED CONSENT FORM

I hereby state that:

- I have read, understood and signed the **Kansas State University, Informed Consent (Template)** Form.
- I have agreed to be interviewed a total of three (3) times in Fall 2003 in connection with the study described in the **Kansas State University, Informed Consent (Template)** Form.
- I understand that information collected from me during this interview process, including any demographic information will be kept strictly confidential by the Project Staff. Audiotapes of the interview, and their transcripts will be stored in a secure place, and will be destroyed after the publication of the research resulting from this study.
- I understand that I will not be identified either by name or by any other identifying feature in any communication, written or oral, pertaining to this research.
- I understand that if I wish to withdraw from the study at any time, either before a scheduled interview, during an interview or after an interview I can do so without explanation, penalty, or loss of benefits, or academic standing that I may otherwise be entitled.
- I understand that by signing this form, I have consented to have information learned from me during the process to be used by the Project Staff in their research and any resulting publications.
- I understand that *if I agree to all three (3) interviews in Fall 2003 pertaining to this project and if I allow my data to be used in the research (by signing this form) then I will be compensated for my participation for a total sum of \$30 at the end of the third interview.*

Participant Name: _____

Participant Signature _____

Date: _____

Witness to Signature _____
(Project Staff)

Date: _____

**APPENDIX C
PILOT SURVEY**

APPENDIX D
PRE-INSTRUCTION SURVEYS

D.1 VERSION 1

D.2 VERSION 2

D.3 VERSION 3

D.4 VERSION 4

APPENDIX E
POST-INSTRUCTION #1 SURVEYS

E.1 VERSION 1

E.2 VERSION 2

E.3 VERSION 3

E.4 VERSION 4

APPENDIX F
POST-INSTRUCTION #2 SURVEYS

F.1 VERSION 1

F.2 VERSION 2

F.3 VERSION 3

F.4 VERSION 4

APPENDIX G

FIRST INTERVIEW

G.1 PROTOCOL (PILOT-TEST)

Name: _____	_____, 2003	Time In ~ ____ : ____ m
I. D. # _____		Time Out ~ ____ : ____ m
Geometric & Displacement/Projectile Motion/Forces		
Post-Instruction & Post-Testing		

I Today you will solve three questions based on the concepts of displacement, projectile motion, and forces. During your explanation of your solution, please try to say your thoughts verbally and when necessary, specify your thoughts and/or actions by pointing to the figure if it helps you explain your thoughts or actions. I will be taking notes throughout the interview, so please do not become distracted by my writing (i.e. the notes may be my explanation of you pointing to a figure).

____ : ____ m

I (Handout Exam 1) Here is the first exam, Exam 1 that you took in General Physics I on Tuesday, September 16, 2003. Which of the last three questions (6, 7, and 8) from Exam 1 did you find most difficult and which did you find least difficult to answer by explaining why you chose the particular question?

____ : ____ m

I (Handout Question 01) Please read question 01 which is similar to question number six from Exam 1 and let me know when you are finished reading.

I What mathematics and physics concepts are relevant in order to solve Question 01?

I Explain how the mathematics and physics concepts are relevant to Question 01?

I How would you begin solving Question 01?

I Okay, you may begin explaining your solution to Question 01.

Explain symbols:

I What does the symbol ?? represent?

Point to symbols on figures:

I Would you please point to the (angle, symbol, point) on your figure?

Explain equations:

I Why did you decide to use the equation you wrote down?

Prompt interviewees if they are not making progress with non-trigonometry parts.

I Why did you use (cosine, sine, tangent) of ?? angle?

<input type="checkbox"/> Difficulty with V_{0x}			
I Suppose the initial velocity is in the x -direction and assume: $v_{0x} = 7 \frac{\text{m}}{\text{s}}$			
I Now try to finish your solution.			
	<input type="checkbox"/> Difficulty with V_x and V_y	<input type="checkbox"/> No Difficulty	
	(Handout Figure 01)		
	I Please look at Figure 01 and let me know when you are finished.		
	I What does 'A' equal to in terms of 'C'?		
	I What does 'B' equal to in terms of 'C'?		
	I What does ' θ ' equal to in terms of 'A' and 'B'?		
	I What physical quantity in Question 01 does 'A' represent?		
	I What physical quantity in Question 01 does 'B' represent?		
	I What physical quantity in Question 01 does 'C' represent?		
	I What physical quantity in Question 01 does ' θ ' represent?		
	I Now try to solve Question 01.		
	I Did anything at all about Figure 01 prompt you to solve Question 01? If so, what?		

(After 12 minutes)

We have two additional questions to look at today, so we will leave this question and come back to Question 01 if there is time left at the end.

(If 12 minutes have not passed, Handout Figure 02)

Before you move on to Question 02, I have one supplemental question for you.

What information do you need to know to find the magnitude of the velocity ' v ' and the angle ' θ ' at point 'P' in the following figure?

Can you think of any other ways to solve Question 01?

___ : ___ m

- I (Handout Question 02) Please read Question 02 and let me know when you are finished reading.
 - I What mathematics and physics concepts are relevant in order to solve Question 02?
 - I Explain how the mathematics and physics concepts are relevant to Question 02.
 - I How would you begin solving Question 02?
 - I Okay, you may begin explaining your solution to Question 02.
 - Explain symbols:
 - I What does the symbol θ represent?
 - Point to symbols on figures:
 - I Would you please point to the (angle, symbol, point) on your figure?
 - Explain equations:
 - I Why did you decide to use the equation you wrote down?
- Prompt interviewees if they are not making progress with non-trigonometry parts.
- I Why did you use (cosine, sine, tangent) of θ angle?

<input type="checkbox"/> Difficulty with figure If wrong angle is chosen.		
I Why did you choose to place the angle there on your figure?		
If continuing to have difficulty. (Handout Figure 03)		
I Now try to finish your solution.		
	<input type="checkbox"/> Difficulty with resultant displacement	<input type="checkbox"/> No Difficulty
	(Handout Figure 04)	
	I Please look at Figure 04 and let me know when you are finished.	
	I What is the length 'C' equal to in terms of 'A, B, α , and β '?	
	I What does the angle gamma ' γ ' equal to in terms of 'C'?	
	I Now try to solve Question 02.	
	If still continuing to have difficulty with components?	
	I What about adding similar components of each vector?	
	I Now try to solve Question 02.	
	I What about Figure 04 prompted you to solve Question 02?	

(After 12 minutes) We have one additional question to look at today, so we will leave this question and come back to Question 01 and/or Question 02 if there is time left at the end.

(If 12 minutes have not passed) Can you think of any other ways to solve Question 02?

____:____ m

- I (Handout Question 03) Please read Question 03 which is the same as question number eight on Exam 1 and let me know when you are finished reading.
- I What mathematics and physics concepts are relevant in order to solve Question 03?
- I Explain how the mathematics and physics concepts are relevant to Question 03?
- I How would you begin solving Question 03?
- I Okay, you may begin explaining your solution to Question 03.

Explain symbols:

- I What does the symbol ? represent?

Point to symbols on figures:

- I Would you please point to the (angle, symbol, point) on your figure?

Explain equations:

- I Why did you decide to use the equation you wrote down?

Prompt interviewees if they are not making progress with non-trigonometry parts.

- I Why did you use (cosine, sine, tangent) of ? angle?

<input type="checkbox"/> Difficulty with sum of the forces			
I Suppose the sum of the forces is $F_x = 16 \text{ N}$ and is directed toward the left.			
I Now try to finish your solution.	<input type="checkbox"/> Difficulty with Darryl's horizontal force component	<input type="checkbox"/> No Difficulty	
	(Handout Figure 05)		
	I Please look at Figure 05 and let me know when you are finished.		
	I What is the length 'B' equal to in terms 'A' and 'θ'?		
	I What physical quantity in Question 03 does 'A' represent?		
	I What physical quantity in Question 03 does 'B' represent?		
	I What physical quantity in Question 03 does 'θ' represent?		
	I Now try to solve Question 03.		
	I What about Figure 05 prompted you to solve Question 03?		

(After 12 minutes) We can now go back to Question 01 and/or Question 02 if needed.

(If 12 minutes have not passed and do not need to go back to Question 01 or 02)

Can you think of any other ways to solve Question 03?

____:______m

G.2 QUESTIONS (PILOT-TEST)

Question 01

Larry is running off the end of a pier with the intention of jumping in the water 4.0 meters below. There's a buoy 6.4 meters from the end of the pier that marks the point where the water's deep enough to safely jump in. Assuming Larry leaves the pier going straight out (horizontal) and air resistance is negligible,

- how fast does he have to be running in order to make it past the buoy?
- what is the horizontal velocity component *just before* he hits the water?
- what is the vertical velocity component *just before* he hits the water?
- at what angle does he hit the water with respect to the horizontal?

Question 02

What is Larry's resultant displacement from the origin if he takes a walking tour with the following four parts described below?

Part 1: A = 400 meters at 30° east of north.

Part 2: B = 200 meters at 20° south of east.

Part 3: C = 850 meters at 60° north of west.

Part 4: D = 300 meters due south.

Question 03

A 34 kg cart with well-oiled wheels (so you can ignore friction) sits on a level floor. Larry is trying to push it to the right with a force of 250 N directly to the right. Darryl is pushing to the left with a force of 270 N, but he's pushing down 10° from the horizontal (mostly left, a little down). If the cart starts at rest, how far will it have gone and in what direction after 15 seconds, assuming Larry and Darryl keep their forces constant? You may assume that the floor is strong enough to hold the cart up even with Darryl pushing the cart down some.

G.3 FIGURES (PILOT-TEST)

Figure 01

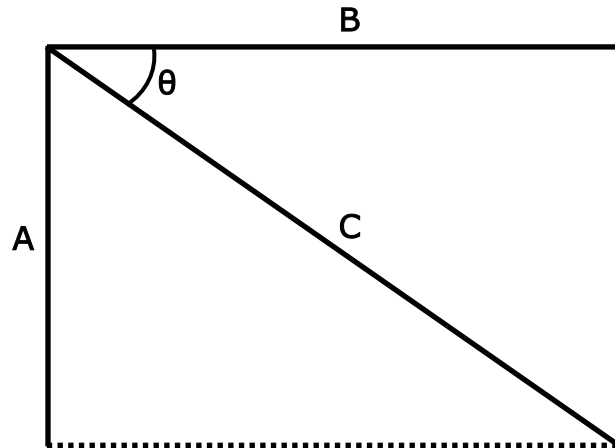

Figure 02

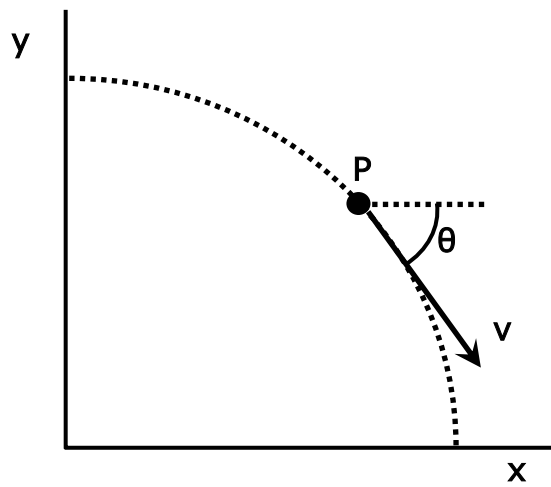

Figure 03

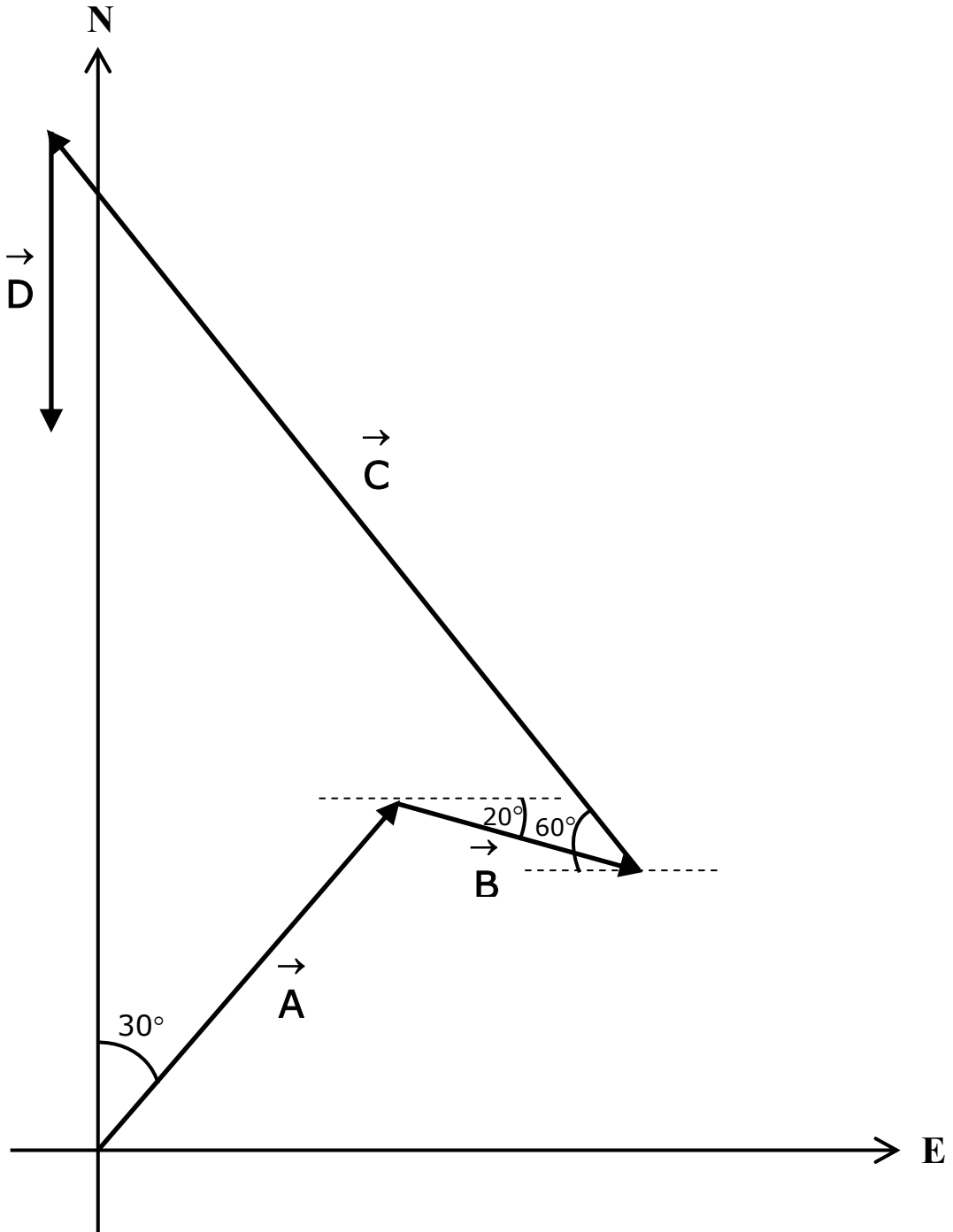

Figure 04

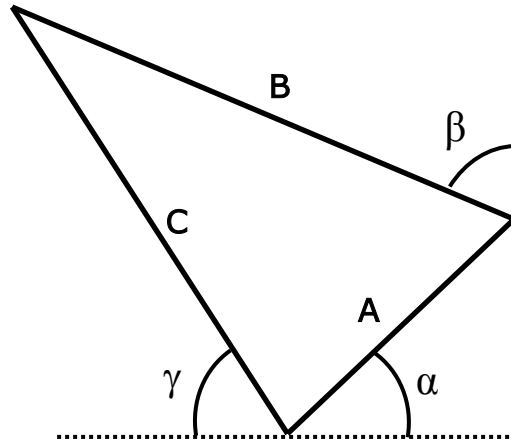
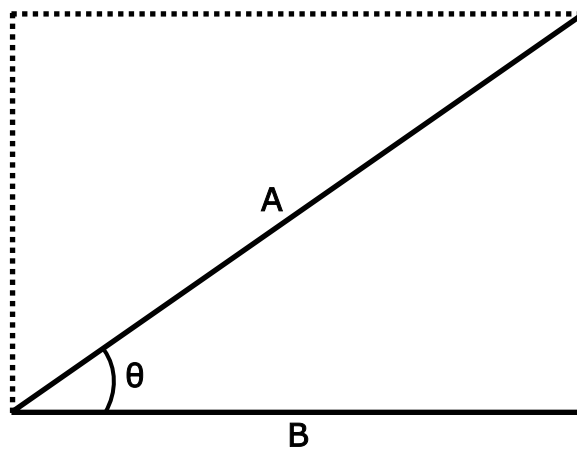

Figure 05



G.4 PROTOCOL

Name: _____	_____, 2003	Time In ~ ____ : ____ m
I. D. # _____		Time Out ~ ____ : ____ m
Geometric & Displacement/Projectile Motion		
Post-Instruction & Post-Testing		

- Review and Sign “Informed Consent Template” and “Addendum to Informed Consent Template Form” and let students know that I will copy the “Informed Consent Template” for them.
- Some students were having difficulty with Question 01, so try not to become frustrated. You will not be receiving a grade for solving the questions.
- Write everything you can on your paper without erasing and say all of your thoughts verbally. Try not to become distracted by my writing. I may be asking a question to follow-up on what you wrote, even if it is correct as well as incorrect.

I (Start Tape) Today you will solve questions based on the concepts of projectile motion and displacement. During your explanation of the solutions, please try to say your thoughts and actions verbally. If it helps to explain your solution, specify your thoughts and/or actions by pointing to the figure. I will be taking notes throughout the interview, so please do not become distracted by my writing (i.e. the notes may be my explanation of you pointing to an angle on the figure).

____ : ____ m

- I (Handout Exam 1) Here is Exam 01 that you took in General Physics I on Tuesday, September 16, 2003.
- I Which of the last three questions (6, 7, and 8) from Exam 1 did you find most difficult to answer and why?
- I Which of the last three questions (6, 7, and 8) from Exam 1 did you find least difficult to answer and why?
- I (Handout Equations – Front & Back) Before we begin with Question 01, what notation are you familiar with from the following equation sheet? The first side, page 1, has equations taken from the class notes and the second side, page 2, has equations taken from the textbook.
- I You may use the equation sheet while solving the questions.

____ : ____ m

- I (Handout Question 01) Please read Question 01 which is similar to question number six on Exam 1 and let me know when you are finished reading.
- I What mathematics concepts are relevant in order to solve Question 01 and explain your reasoning?
- I What physics concepts are relevant in order to solve Question 01 and explain your reasoning?
- I How would you begin solving Question 01?
- I Okay, you may begin explaining your solution to Question 01.

Equations:
I What is your reasoning for using the equation you wrote on your paper?
If not making progress with non-trigonometric parts:
I Why did you use (cosine, sine, tangent, etc.) of the angle $\theta, \alpha, \beta, \gamma, \text{ etc.}$?

<input type="checkbox"/> Difficulty with <input type="checkbox"/> v_x , <input type="checkbox"/> v_y , <input type="checkbox"/> v , or <input type="checkbox"/> θ .	<input type="checkbox"/> No Difficulty.
(Handout Figure 01)	
<input type="checkbox"/> Please look at Figure 01 and let me know when you are finished.	
<input type="checkbox"/> What does 'C' equal to in terms of 'A' and 'B'?	
<input type="checkbox"/> What does ' θ ' equal to in terms of 'A' and 'B'?	
<input type="checkbox"/> What physical quantity in Question 01 does 'A' represent?	
<input type="checkbox"/> What physical quantity in Question 01 does 'B' represent?	
<input type="checkbox"/> What physical quantity in Question 01 does 'C' represent?	
<input type="checkbox"/> What physical quantity in Question 01 does ' θ ' represent?	
<input type="checkbox"/> Now try to solve Question 01.	
<input type="checkbox"/> Did anything at all about Figure 01 prompt you to solve Question 01? If so, what?	

After 20 minutes	If 20 minutes have not passed
<input type="checkbox"/> We have an additional question to look at today, so we will leave this question and come back to Question 01 if there is time left at the end.	(Handout Figure 02)
	<input type="checkbox"/> Before you move on to Question 02, I have one supplemental question for you.
	<input type="checkbox"/> What information do you need to know to find the magnitude of the velocity ' v ' and the angle ' θ ' at point 'P' in the following figure?

____ : ____ m

- I (Handout Question 02) Please read Question 02 and let me know when you are finished reading.
- I What mathematics concepts are relevant in order to solve Question 02 and explain your reasoning?
- I What physics concepts are relevant in order to solve Question 02 and explain your reasoning?
- I How would you begin solving Question 02?
- I Okay, you may begin explaining your solution to Question 02.

Equations:
I What is your reasoning for using the equation you wrote on your paper?
If not making progress with non-trigonometric parts:
I Why did you use (cosine, sine, tangent, etc.) of the angle $\theta, \alpha, \beta, \gamma, \text{ etc.}$?

Angles:	
I Why did you choose to place the ___° angle there on your figure? →	20°:
<input type="checkbox"/> Difficulty with Figure. (Handout Figure 03)	30°:
<input type="checkbox"/> Here is Figure 03, now try to finish your solution.	60°:
<input type="checkbox"/> Difficulty with resultant displacement. <input type="checkbox"/> No Difficulty. (Handout Figure 04)	
<input type="checkbox"/> Please look at Figure 04 and let me know when you are finished.	
<input type="checkbox"/> What is the length 'C' equal to in terms of 'A, B, α , and β '?	
<input type="checkbox"/> What does the angle gamma ' γ ' equal to in terms of 'A, B, C, α , and/or β '?	
<input type="checkbox"/> Now try to solve Question 02.	<input type="checkbox"/> Difficulty with resultant of Figure 04. (Handout Figure 05) <input type="checkbox"/> Please look at Figure 05 and let me know when you are finished. → <input type="checkbox"/> What is the length 'C' equal to in terms of 'A, B, α , and β '? → <input type="checkbox"/> What does the angle gamma ' γ ' equal to in terms of 'A, B, C, α , and/or β '? → <input type="checkbox"/> Now try to solve Question 02.
<input type="checkbox"/> What about Figure 04 prompted you to solve Question 02?	<input type="checkbox"/> What about Figure 05 prompted you to solve Question 02?

(After 20 minutes) We have ___ minutes remaining (if 40 minutes are not complete), so let's go back to Question ___?
 ____:____ m

G.5 EQUATION SHEET

Equations: Class Notes

$$\Delta x = v_i t + \frac{1}{2} a t^2$$

$$v_f = v_i + a t$$

$$v_f^2 = v_i^2 + 2 a \Delta x$$

Equations: Textbook

$$x = x_0 + v_0 t + \frac{1}{2} a t^2$$

$$v = v_0 + a t$$

$$v^2 = v_0^2 + 2 a (x - x_0)$$

G.6 QUESTIONS

Question 01

Larry is running off the end of a pier with the intention of jumping in the water 4.0 meters below. There's a buoy 6.4 meters from the end of the pier that marks the point where the water's deep enough to safely jump in. Larry leaves the pier with an initial speed of 7.0 m/s going straight out (horizontal) in order to make it past the buoy. Assume air resistance is negligible.

- What is the horizontal velocity component *just before* he hits the water? *Answer* = $7.0 \frac{\text{m}}{\text{s}}$
- What is the vertical velocity component *just before* he hits the water? *Answer* = $-8.85 \frac{\text{m}}{\text{s}}$
- What is his speed *just before* he hits the water?
- At what angle does he hit the water with respect to the horizontal?

Question 02

What is Larry's resultant displacement from the origin if he takes a walking tour with the following four parts described below?

- Part 1: A = 400 meters at 30° east of north.
Part 2: B = 200 meters at 20° south of east.
Part 3: C = 850 meters at 60° north of west.
Part 4: D = 300 meters due south.

G.7 FIGURES

Figure 01

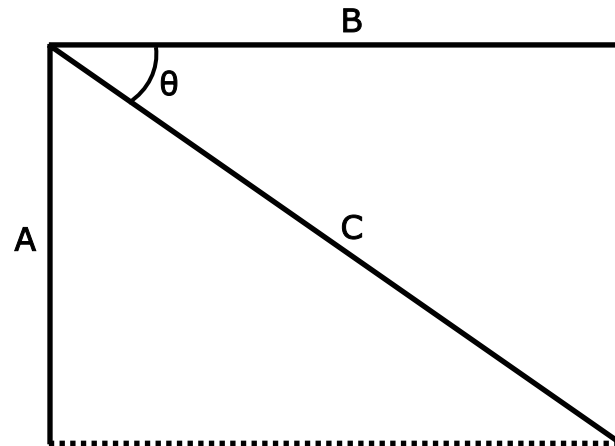

Figure 02

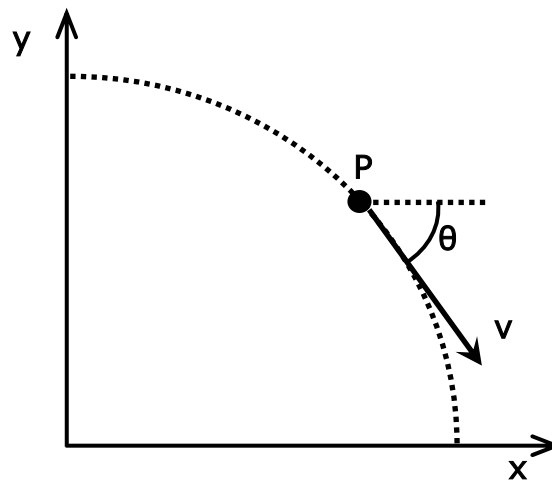

Figure 03

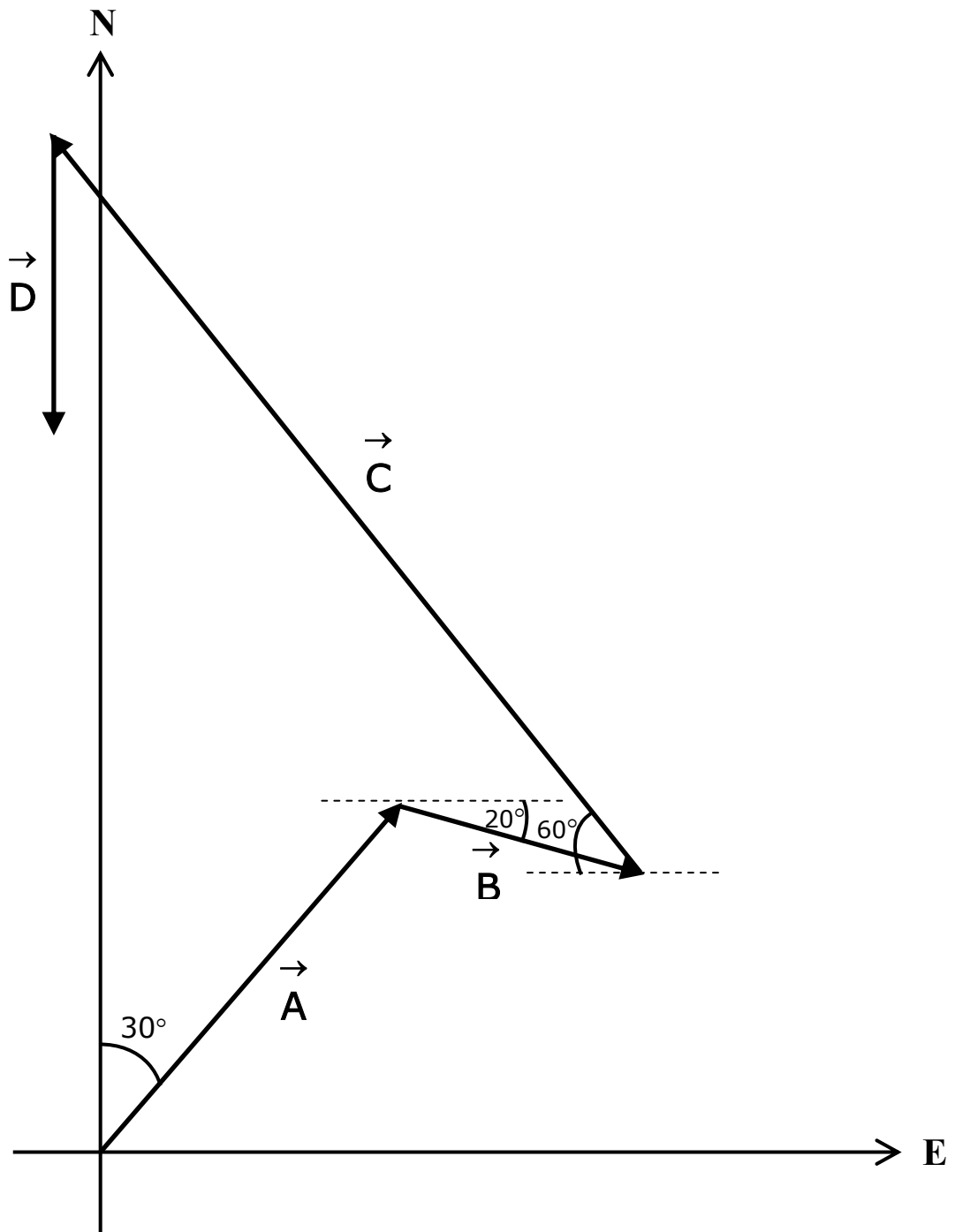

Figure 04

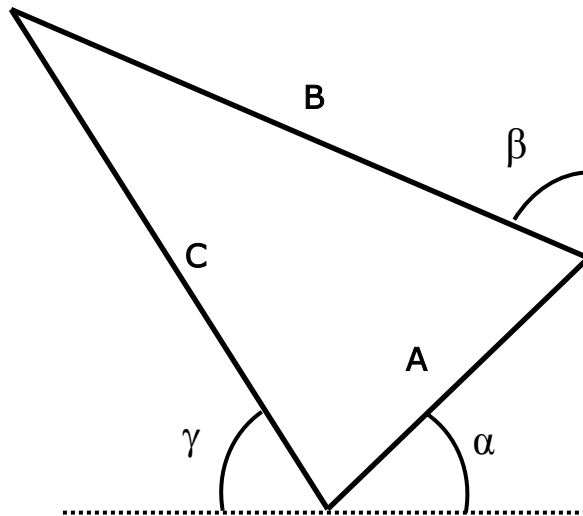
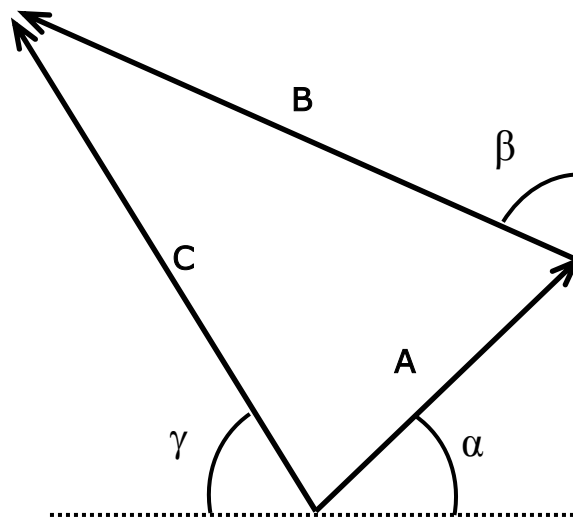

Figure 05



APPENDIX H SECOND INTERVIEW

H.1 PROTOCOL (PILOT-TEST)

Name: _____	_____, 2003	Time In ~ ____ : ____ m
I.D.# _____		Time Out ~ ____ : ____ m
Geometric/Unit Circle & Forces/Rotational Motion/Bodies in Equilibrium		
Post-Instruction & Post-Testing		

I (Start Tape) Today you will solve questions based on the concepts of forces, rotational motion, and possibly bodies in equilibrium. During your explanation of the solutions, please try to say your thoughts and actions verbally. If it helps to explain your solution, specify your thoughts and/or actions by pointing to the figure. Write everything you possibly can on your paper without erasing. I will be taking notes throughout the interview, so please do not become distracted by my writing (for example the notes may be my explanation of you pointing to an angle on the figure). I may be asking a follow-up question on what you wrote, even if it is correct or incorrect.

____ : ____ m

I (Handout Question 01) Please read Question 01 and let me know when you are finished reading.

I Okay, you may begin explaining your solution to Question 01.

<input type="checkbox"/> Difficulty with <input type="checkbox"/> w_x or <input type="checkbox"/> w_y .	<input type="checkbox"/> No Difficulty.
(Handout Figure 01)	
<input type="checkbox"/> Please look at Figure 01 and let me know when you are finished.	
<input type="checkbox"/> What is ' α ' in terms of ' θ '?	<input type="checkbox"/> Difficulty with <input type="checkbox"/> ' α ' or <input type="checkbox"/> ' β '.
	(Handout Figure 02)
	<input type="checkbox"/> Please look at Figure 02 and let me know when you are finished.
<input type="checkbox"/> What is ' β ' in terms of ' θ '?	<input type="checkbox"/> What is ' α ' in terms of ' θ '?
	<input type="checkbox"/> What is ' β ' in terms of ' θ '?
<input type="checkbox"/> Now try to solve Question 01.	
<input type="checkbox"/> Did anything at all about Figure (01 OR 02) prompt you to solve Question 01? If so, what?	

<input type="checkbox"/> Continued difficulty with <input type="checkbox"/> w_x or <input type="checkbox"/> w_y .	
(Handout Figure 03)	
<input type="checkbox"/> Please look at Figure 03 and let me know when you are finished.	
<input type="checkbox"/> What is 'a' in terms of 'c' and 'θ'?	
<input type="checkbox"/> What is 'b' in terms of 'c' and 'θ'?	
<input type="checkbox"/> What physical quantity in Question 01 does 'a' represent? Why?	
<input type="checkbox"/> What physical quantity in Question 01 does 'b' represent? Why?	
<input type="checkbox"/> What physical quantity in Question 01 does 'c' represent? Why?	
<input type="checkbox"/> What physical quantity in Question 01 does 'θ' represent? Why?	
<input type="checkbox"/> Now try to solve Question 01.	
<input type="checkbox"/> Did anything at all about Figure 03 prompt you to solve Question 01? If so, what?	
<input type="checkbox"/> (After 20 minutes) We have an additional question to look at today, so we will leave this question and come back to Question 01 if there is time left at the end.	

____:____ __m

I (Handout Question 02) Please read Question 02 and let me know when you are finished reading.

I Okay, you may begin explaining your solution to Question 02.

<input type="checkbox"/> No Difficulty.	
<input type="checkbox"/> Difficulty with 'θ'. → Consider the equation $\omega = \frac{\Delta\theta}{\Delta t}$. Are you now able to solve for 'θ'?	
<input type="checkbox"/> Difficulty with P(x,y)	<input type="checkbox"/> No Difficulty.
(Handout Figure 04)	
<input type="checkbox"/> Please look at Figure 04 and let me know when you are finished.	
<input type="checkbox"/> What is 'α' in terms of 'β'?	
<input type="checkbox"/> What physical quantity in Question 02 does 'β' represent? Why?	
<input type="checkbox"/> What physical quantity in Question 02 does 'α' represent? Why?	
<input type="checkbox"/> Now try to solve Question 02.	
<input type="checkbox"/> Did anything at all about Figure 04 prompt you to solve Question 02? If so, what?	

<input type="checkbox"/> Continued difficulty with 'P(x,y)'.	
(Handout Figure 05)	
<input type="checkbox"/> Please look at Figure 05 and let me know when you are finished.	
<input type="checkbox"/> What is 'α' in terms of 'β'?	
<input type="checkbox"/> What is 'a' in terms of 'c' and 'β'?	
<input type="checkbox"/> What is 'b' in terms of 'c' and 'β'?	
<input type="checkbox"/> What physical quantity in Question 02 does 'a' represent? Why?	
<input type="checkbox"/> What physical quantity in Question 02 does 'b' represent? Why?	
<input type="checkbox"/> What physical quantity in Question 02 does 'c' represent? Why?	
<input type="checkbox"/> What physical quantity in Question 02 does 'β' represent? Why?	
<input type="checkbox"/> Now try to solve Question 02.	
<input type="checkbox"/> Did anything at all about Figure 05 prompt you to solve Question 02? If so, what?	
<input type="checkbox"/> (After 20 minutes) We have _____ additional minutes remaining so we can go back to Question 01 or continue working on Question 02.	
<input type="checkbox"/> (If < 42 minutes and answered Question 01 and 02) I have one supplemental question for you, Question 03?	

____:____ __m

I (Handout Question 03) Please read Question 03 and let me know when you are finished reading.

I Okay, you may begin explaining your solution to Question 03.

<input type="checkbox"/> No Difficulty.	
<input type="checkbox"/> Difficulty with labeling forces. → Label the forces $F_{Hx}, F_{Hy}, F_{Tx}, F_{Ty}, F_T$ on the diagram	
<input type="checkbox"/> Difficulty with $\sum F_x = 0 \rightarrow$ write $\sum F_x = F_{Hx} - F_{Tx} = 0$	
<input type="checkbox"/> Difficulty with $\sum F_y = 0 \rightarrow$ write $\sum F_y = F_{Hy} + F_{Ty} - mg - Mg = 0$	
<input type="checkbox"/> Difficulty with $\sum \tau = 0 \rightarrow$ write $\sum \tau = -(F_{Hy})(2.20m) + (mg)(1.10m) = 0$	

<input type="checkbox"/> Difficulty with \vec{F}_T .		<input type="checkbox"/> No Difficulty.
(Handout Figure 06)		
<input type="checkbox"/> Please look at Figure 06 and let me know when you are finished.		
<input type="checkbox"/> What is 'b' in terms of 'a' and 'θ'?	<input type="checkbox"/> Difficulty with 'b'.	<input type="checkbox"/> No Difficulty.
	(Handout Figure 07)	
	<input type="checkbox"/> Please look at Figure 07 and let me know when you are finished.	
	<input type="checkbox"/> What is 'b' in terms of 'a' and 'θ'?	
<input type="checkbox"/> What physical quantity in Question 03 does 'a' represent? Why?		
<input type="checkbox"/> What physical quantity in Question 03 does 'b' represent? Why?		
<input type="checkbox"/> What physical quantity in Question 03 does 'θ' represent? Why?		
<input type="checkbox"/> Now try to solve Question 03.		
<input type="checkbox"/> Did anything at all about Figure (06 OR 07) prompt you to solve Question 03? If so, what?		
<input type="checkbox"/> Continued difficulty with 'b'.		<input type="checkbox"/> No Difficulty.
(Handout Figure 08)		
<input type="checkbox"/> Please look at Figure 08 and let me know when you are finished.		
<input type="checkbox"/> What is 'α' in terms 'θ'?		
<input type="checkbox"/> What is 'b' in terms of 'a' and 'θ'?		
<input type="checkbox"/> What physical quantity in Question 03 does 'a' represent? Why?		
<input type="checkbox"/> What physical quantity in Question 03 does 'b' represent? Why?		
<input type="checkbox"/> What physical quantity in Question 03 does 'θ' represent? Why?		
<input type="checkbox"/> Now try to solve Question 03.		
<input type="checkbox"/> Did anything at all about Figure 08 prompt you to solve Question 03? If so, what?		

____: ____ m

H.2 EQUATION SHEET (PILOT-TEST)

Equations

$$2\pi \text{ rad} = 360^\circ$$

$$\Sigma F = ma$$

$$\Sigma F_x = ma_x \quad \Sigma F_y = ma_y$$

$$a_c = \frac{v^2}{r}$$

$$v = r \omega$$

$$a_{\text{tan}} = r \alpha$$

$$a_R = \omega^2 r$$

$$\omega = \frac{\Delta\theta}{\Delta t}$$

$$\alpha = \frac{\Delta\omega}{\Delta t}$$

$$\theta = \frac{\ell}{r}$$

$$\omega = \omega_o + \alpha t$$

$$\theta = \omega_o t + \frac{1}{2} \alpha t^2$$

$$\theta = \frac{1}{2}(\omega_o + \omega) t$$

$$\omega^2 = \omega_o^2 + 2 \alpha \theta$$

$$\tau = | r F \sin \theta |$$

$$\Sigma \tau = \Sigma \tau_{\text{counter-clockwise}} - \Sigma \tau_{\text{clockwise}}$$

H.3 QUESTIONS (PILOT-TEST)

Question 01

A uniform block of mass m shown in the following figure lies on a smooth plane tilted at an angle θ to the horizontal. What is the component of the block's weight:

- along the plane?
- perpendicular to the plane?

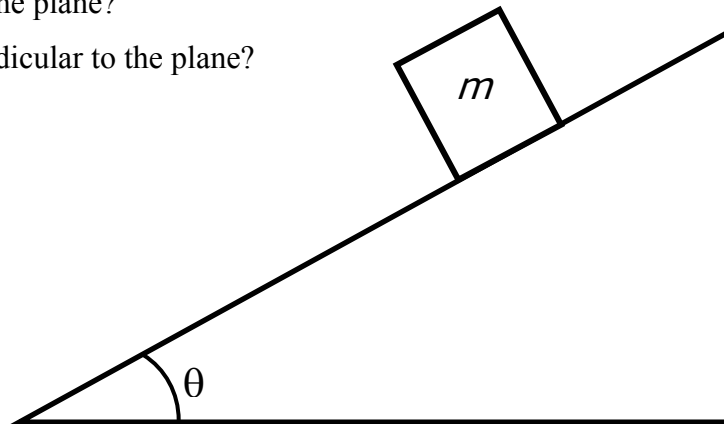

Question 02

A mass m attached to the end of a string revolves in a circle of radius $r = 1$ m while being whirled around (see the aerial view in the following figure). The initial position when $t = 0$ of the ball at a point $P(x,y)$ in the following figure is $P(0,1)$. The ball moves along the circular path at an angular speed of $\omega = \pi/6$ radian per second. What is the:

- x -position after 2 seconds?
- y -position after 2 seconds?

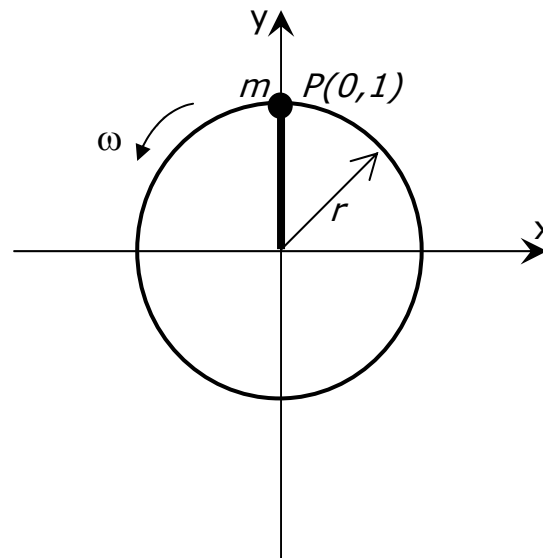

Question 03

A uniform beam, 2.20 m long with mass $m = 25.0$ kg is mounted on a wall as shown in the following figure. The beam is held in a horizontal position by a wire that makes an angle $\theta = 30.0^\circ$ as shown. The beam supports a mass $M = 280$ kg suspended from its end. Determine the:

- vertical component of the tension
 F_{Ty} in the supporting wire.
- horizontal component of the tension
 F_{Tx} in the supporting wire.
- tension \vec{F}_T in the supporting wire.

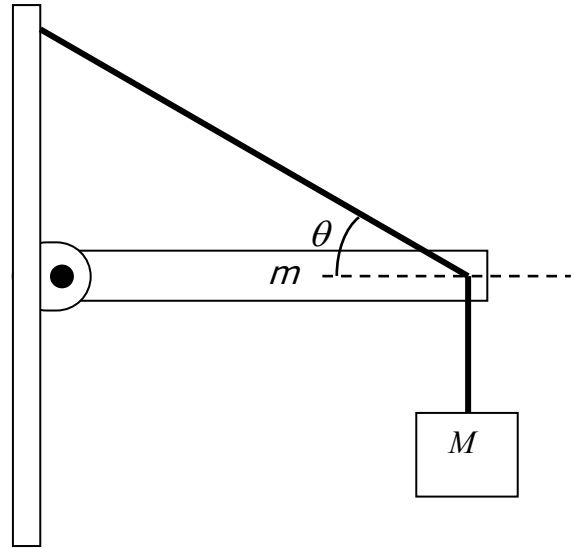

H.4 FIGURES (PILOT-TEST)

Figure 01

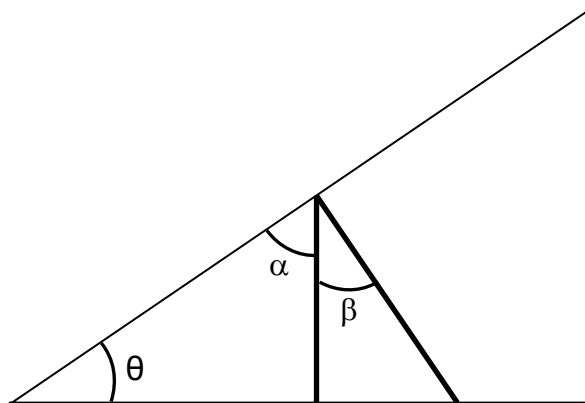

Figure 02

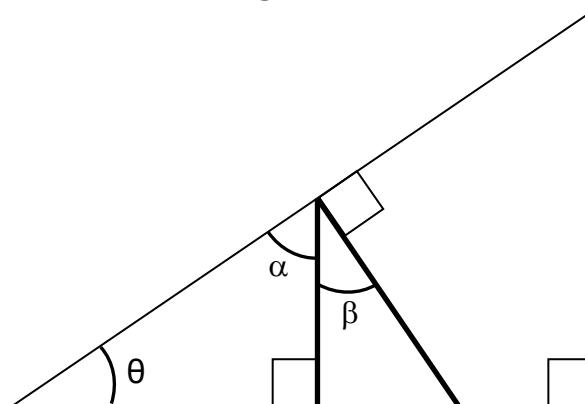

Figure 03

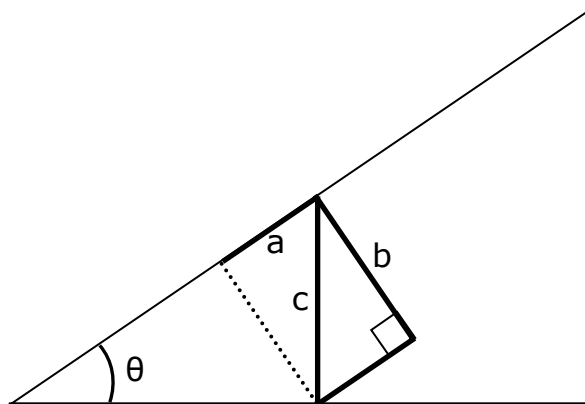

Figure 04

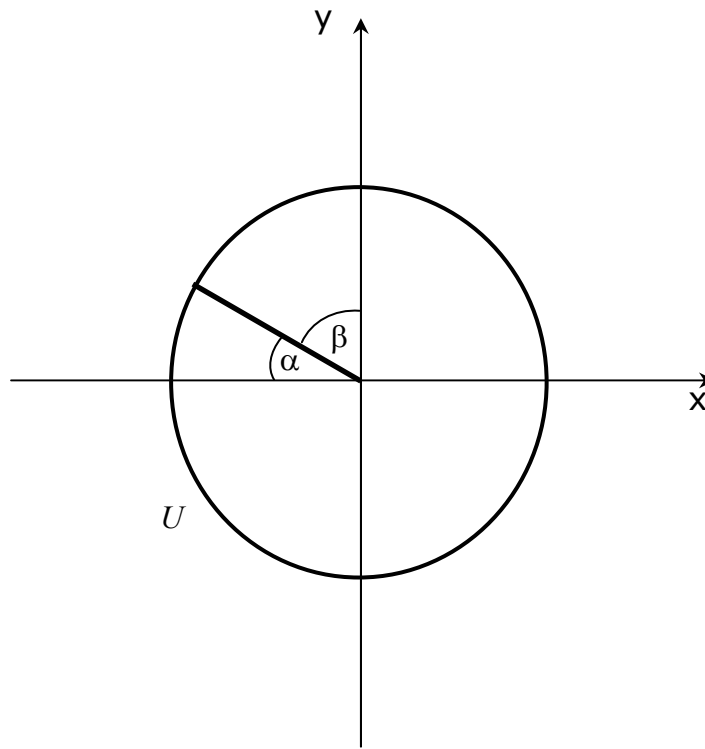

Figure 05

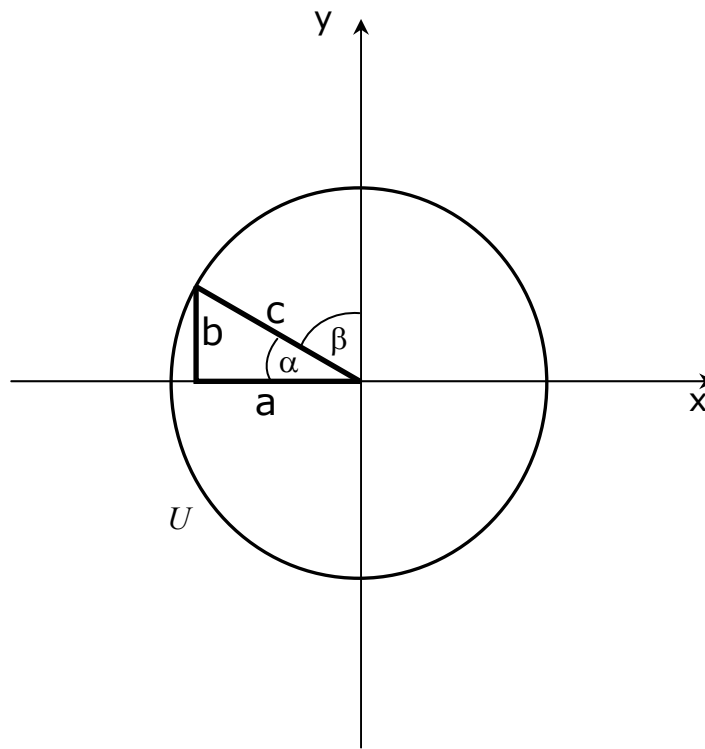

Figure 06

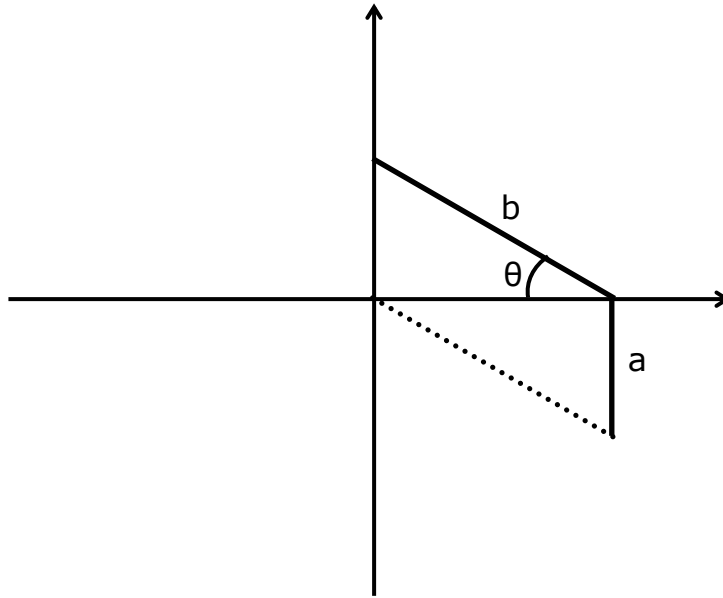

Figure 07

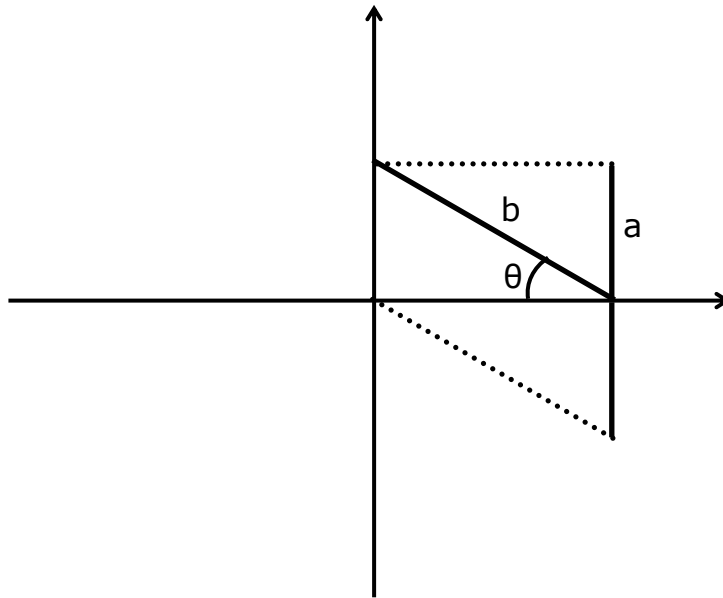
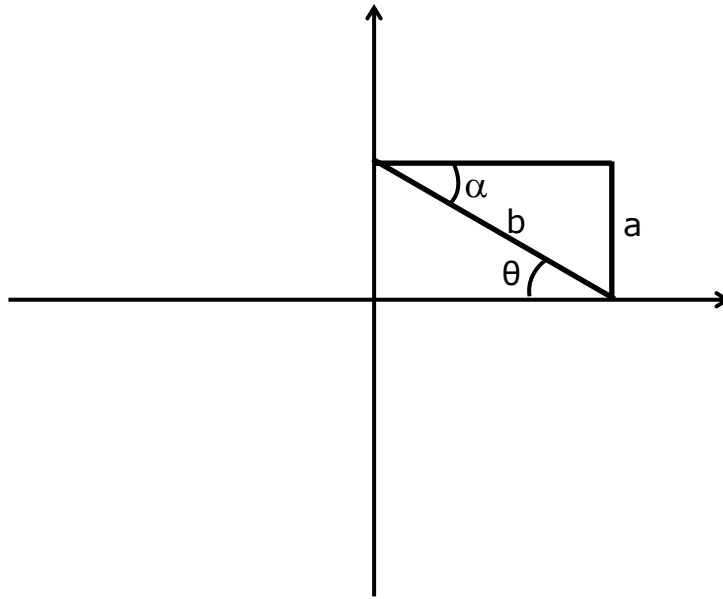

Figure 08



H.5 PROTOCOL

Name: _____	_____, 2003	Time In ~ ____ : ____ m
I.D.# _____		Time Out ~ ____ : ____ m
Geometric/Unit Circle & Forces/Rotational Motion/Bodies in Equilibrium		
Post-Instruction & Post-Testing		

____ : ____ m

- I (Handout Equation Sheet) Please look at the equation sheet so that you become familiar with the equations.
- I (Start Tape) Today you will solve questions based on the concepts of forces, rotational motion, and possibly bodies in equilibrium. During your explanation of the solutions, please try to say your thoughts and actions verbally. If it helps to explain your solution, specify your thoughts and/or actions by pointing to the figure. Write everything you possibly can on your paper without erasing. I will be taking notes throughout the interview, so please do not become distracted by my writing (for example the notes may be my explanation of you pointing to an angle on the figure which is something the audio tape cannot pick-up). I may be asking follow-up questions on what you wrote, even if what you wrote is correct or incorrect.

____ : ____ m

- I (Handout Question 01) Please read Question 01 and let me know when you are finished reading.
- I Okay, you may begin explaining your solution to Question 01.
- Note: Remember to ask WHY if they rotated their paper when solving a Question or Figure.

<input type="checkbox"/> Difficulty with <input type="checkbox"/> w_x or <input type="checkbox"/> w_y .		<input type="checkbox"/> No Difficulty.
(Handout Figure 01)		
<input type="checkbox"/> Please look at Figure 01 and let me know when you are finished.		
<input type="checkbox"/> What is ' α ' in terms of ' θ '?		<input type="checkbox"/> Why?
<input type="checkbox"/> What is ' β ' in terms of ' θ '? <input type="checkbox"/> Why?	<input type="checkbox"/> Difficulty with <input type="checkbox"/> α or <input type="checkbox"/> β .	
	<input type="checkbox"/> No Difficulty.	
	(Handout Figure 02)	
	<input type="checkbox"/> Please look at Figure 02 and let me know when you are finished.	
	<input type="checkbox"/> What is ' α ' in terms of ' θ '?	
<input type="checkbox"/> Why?		<input type="checkbox"/> What is ' β ' in terms of ' θ '?
<input type="checkbox"/> Why?		<input type="checkbox"/> Why?
<input type="checkbox"/> Now try to solve Question 01.		
<input type="checkbox"/> Did anything at all about Figure (01 OR 02) prompt you to solve Question 01? If so, what?		

<input type="checkbox"/> Continued difficulty with <input type="checkbox"/> w_x <input type="checkbox"/> w_y or <input type="checkbox"/> ' β '.	<input type="checkbox"/> No Difficulty.
(Handout Figure 03)	
<input type="checkbox"/> Please look at Figure 03 and let me know when you are finished.	
<input type="checkbox"/> What is 'a' in terms of 'c' and ' θ '? <input type="checkbox"/> Why?	
<input type="checkbox"/> What is 'b' in terms of 'c' and ' θ '? <input type="checkbox"/> Why?	
<input type="checkbox"/> What physical quantity in Question 01 does 'a' represent? <input type="checkbox"/> Why?	
<input type="checkbox"/> What physical quantity in Question 01 does 'b' represent? <input type="checkbox"/> Why?	
<input type="checkbox"/> What physical quantity in Question 01 does 'c' represent? <input type="checkbox"/> Why?	
<input type="checkbox"/> What quantity in Question 01 does ' θ ' represent? <input type="checkbox"/> Why?	
<input type="checkbox"/> Now try to solve Question 01.	
<input type="checkbox"/> Did anything at all about Figure 03 prompt you to solve Question 01? If so, what?	
<input type="checkbox"/> (After 20 minutes) We have an additional question to look at today, so we will leave this question and come back to Question 01 if there is time left at the end.	

____ : ____ m

I (Handout Question 02) Please read Question 02 and let me know when you are finished reading.

I Okay, you may begin explaining your solution to Question 02.

Note: Remember to ask WHY if they rotated their paper when solving and Question or Figure.

<input type="checkbox"/> Difficulty with ' θ '. (They may want to use ω & ω_0 as $\pi/6$ rad/s)	<input type="checkbox"/> No Difficulty.
<input type="checkbox"/> What information do you need to know to solve for the x and y positions?	
<input type="checkbox"/> Are you now able to solve for the x and y positions?	<input type="checkbox"/> No Difficulty.
<input type="checkbox"/> Continued difficulty with ' θ '.	
<input type="checkbox"/> Consider the equation $\omega = \frac{\Delta\theta}{\Delta t}$ <input type="checkbox"/> Are you now able to solve for ' θ '?	
<input type="checkbox"/> Difficulty with P(x,y) <i>PLACEMENT</i> . (<i>VALUES</i> is on the next page)	<input type="checkbox"/> No Difficulty.
<input type="checkbox"/> Where is the initial position?	
<input type="checkbox"/> In what direction is the mass moving?	
<input type="checkbox"/> Would you label the angle on the figure? <input type="checkbox"/> Why did you place the angle there on your figure?	

<input type="checkbox"/> Difficulty with P(x,y) VALUES.	<input type="checkbox"/> No Difficulty.
(Handout Figure 04)	
<input type="checkbox"/> Please look at Figure 04 and let me know when you are finished.	
<input type="checkbox"/> What is 'α' in terms of 'β'?	
<input type="checkbox"/> Why?	
<input type="checkbox"/> What quantity in Question 02 does 'β' represent?	
<input type="checkbox"/> Why?	
<input type="checkbox"/> What quantity in Question 02 does 'α' represent?	
<input type="checkbox"/> Why?	
<input type="checkbox"/> Now try to solve Question 02.	
<input type="checkbox"/> Did anything at all about Figure 04 prompt you to solve Question 02? If so, what?	
<input type="checkbox"/> Continued difficulty with P(x,y) VALUES.	<input type="checkbox"/> No Difficulty.
(Handout Figure 05)	
<input type="checkbox"/> Please look at Figure 05 and let me know when you are finished.	
<input type="checkbox"/> What is 'α' in terms of 'β'?	<input type="checkbox"/> Why?
<input type="checkbox"/> What is 'a' in terms of 'c' and 'β'?	<input type="checkbox"/> Why?
<input type="checkbox"/> What is 'b' in terms of 'c' and 'β'?	<input type="checkbox"/> Why?
<input type="checkbox"/> What physical quantity in Question 02 does 'a' represent?	<input type="checkbox"/> Why?
<input type="checkbox"/> What physical quantity in Question 02 does 'b' represent?	<input type="checkbox"/> Why?
<input type="checkbox"/> What physical quantity in Question 02 does 'c' represent?	<input type="checkbox"/> Why?
<input type="checkbox"/> What quantity in Question 02 does 'β' represent?	<input type="checkbox"/> Why?
<input type="checkbox"/> Now try to solve Question 02.	
<input type="checkbox"/> Did anything at all about Figure 05 prompt you to solve Question 02? If so, what?	
<input type="checkbox"/> (After 20 minutes) We have _____ additional minutes remaining so we can go back to Question 01 or continue working on Question 02.	
<input type="checkbox"/> (If < 42 minutes and answered Question 01 and 02) I have one supplemental question for you, Question 03?	

____:____ __m

I (Handout Question 03) Please read Question 03 and let me know when you are finished reading.

I Okay, you may begin explaining your solution to Question 03.

Note: Remember to ask WHY if they rotated their paper when solving and Question or Figure.

<input type="checkbox"/> No Difficulty.
<input type="checkbox"/> Difficulty with labeling the forces → label the forces $F_{Hx}, F_{Hy}, F_{Tx}, F_{Ty}, F_T$ on the diagram
<input type="checkbox"/> Difficulty with $\sum F_x = 0 \rightarrow$ write $\sum F_x = F_{Hx} - F_{Tx} = 0$
<input type="checkbox"/> Difficulty with $\sum F_y = 0 \rightarrow$ write $\sum F_y = F_{Hy} + F_{Ty} - mg - Mg = 0$
<input type="checkbox"/> Difficulty with $\sum \tau = 0 \rightarrow$ write $\sum \tau = -(F_{Hy})(2.20m) + (mg)(1.10m) = 0$

<input type="checkbox"/> Difficulty with \vec{F}_T .		<input type="checkbox"/> No Difficulty.
(Handout Figure 06)		
<input type="checkbox"/> Please look at Figure 06 and let me know when you are finished.		
<input type="checkbox"/> What is 'b' in terms of 'a' and 'θ'?	<input type="checkbox"/> Difficulty with 'b'.	<input type="checkbox"/> No Difficulty.
	(Handout Figure 07)	
	<input type="checkbox"/> Please look at Figure 07 and let me know when you are finished.	
	<input type="checkbox"/> What is 'b' in terms of 'a' and 'θ'? <input type="checkbox"/> Why?	
<input type="checkbox"/> Why?		
<input type="checkbox"/> What physical quantity in Question 03 does 'a' represent? <input type="checkbox"/> Why?		
<input type="checkbox"/> What physical quantity in Question 03 does 'b' represent? <input type="checkbox"/> Why?		
<input type="checkbox"/> What physical quantity in Question 03 does 'θ' represent? <input type="checkbox"/> Why?		
<input type="checkbox"/> Now try to solve Question 03.		
<input type="checkbox"/> Did anything at all about Figure (06 OR 07) prompt you to solve Question 03? If so, what?		
<input type="checkbox"/> Continued difficulty with 'b'.		<input type="checkbox"/> No Difficulty.
(Handout Figure 08)		
<input type="checkbox"/> Please look at Figure 08 and let me know when you are finished.		
<input type="checkbox"/> What is 'α' in terms 'θ'?	<input type="checkbox"/> Why?	
<input type="checkbox"/> What is 'b' in terms of 'a' and 'θ'?	<input type="checkbox"/> Why?	
<input type="checkbox"/> What physical quantity in Question 03 does 'a' represent? <input type="checkbox"/> Why?		
<input type="checkbox"/> What physical quantity in Question 03 does 'b' represent? <input type="checkbox"/> Why?		
<input type="checkbox"/> What physical quantity in Question 03 does 'θ' represent? <input type="checkbox"/> Why?		
<input type="checkbox"/> Now try to solve Question 03.		
<input type="checkbox"/> Did anything at all about Figure 08 prompt you to solve Question 03? If so, what?		

____ : ____ m

H.6 EQUATION SHEET

Equations

$$2\pi \text{ rad} = 360^\circ$$

$$\Sigma F = ma$$

$$\Sigma F_x = ma_x \quad \Sigma F_y = ma_y$$

$$a_c = \frac{v^2}{r}$$

$$v = r \omega$$

$$a_{\text{tan}} = r \alpha$$

$$a_R = \omega^2 r$$

$$\omega = \frac{\Delta\theta}{\Delta t}$$

$$\alpha = \frac{\Delta\omega}{\Delta t}$$

$$\theta = \frac{\ell}{r}$$

$$\omega = \omega_o + \alpha t$$

$$\theta = \omega_o t + \frac{1}{2} \alpha t^2$$

$$\theta = \frac{1}{2}(\omega_o + \omega) t$$

$$\omega^2 = \omega_o^2 + 2 \alpha \theta$$

$$\tau = | r F \sin \theta |$$

$$\Sigma \tau = \Sigma \tau_{\text{counter-clockwise}} - \Sigma \tau_{\text{clockwise}}$$

H.7 QUESTIONS

Question 01

A uniform block of mass m shown in the following figure lies on a smooth plane tilted at an angle θ to the horizontal. What is the component of the block's weight:

- along the plane?
- perpendicular to the plane?

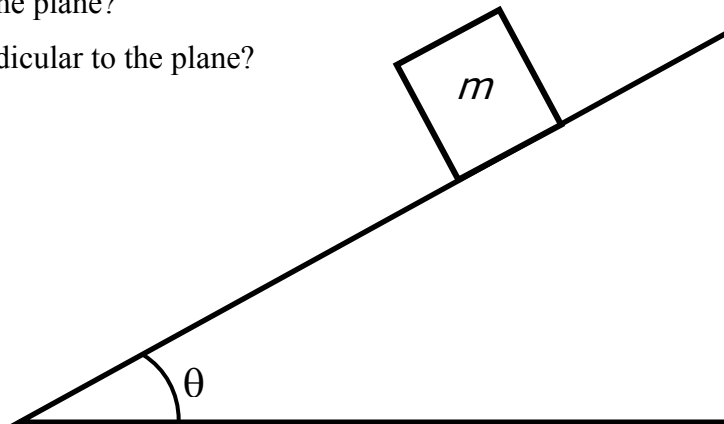

Question 02

A mass m attached to the end of a string revolves in a circle of radius $r = 1$ m while being whirled around (see the aerial view in the following figure). The initial position when $t = 0$ of the ball at a point $P(x,y)$ in the following figure is $P(0,1)$. The ball moves along the circular path at an angular speed of $\omega = \pi/6$ radian per second. What is the:

- x -position after 2 seconds?
- y -position after 2 seconds?

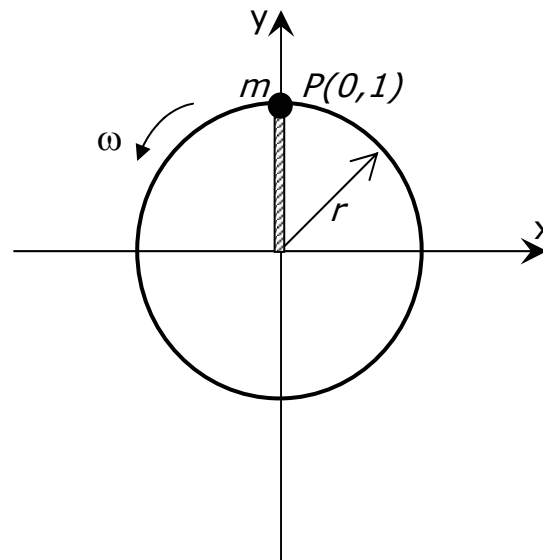

Question 03

A uniform beam, 2.20 m long with mass $m = 25.0$ kg is mounted on a wall as shown in the following figure. The beam is held in a horizontal position by a wire that makes an angle $\theta = 30.0^\circ$ as shown. The beam supports a mass $M = 280$ kg suspended from its end. Determine the:

- vertical component of the tension
 F_{Ty} in the supporting wire.
- horizontal component of the tension
 F_{Tx} in the supporting wire.
- tension \vec{F}_T in the supporting wire.

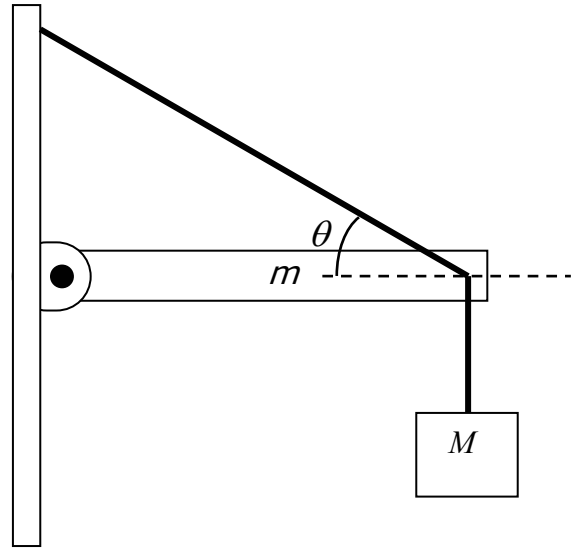

H.8 FIGURES

Figure 01

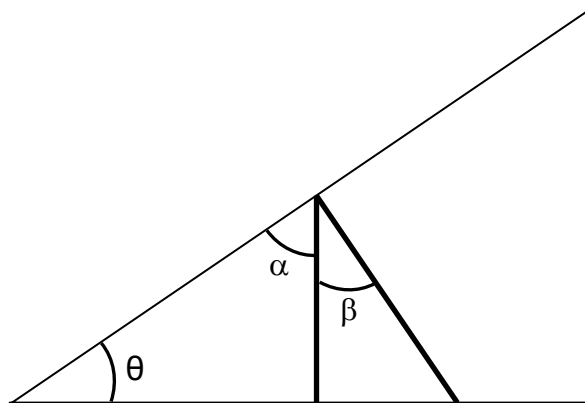

Figure 02

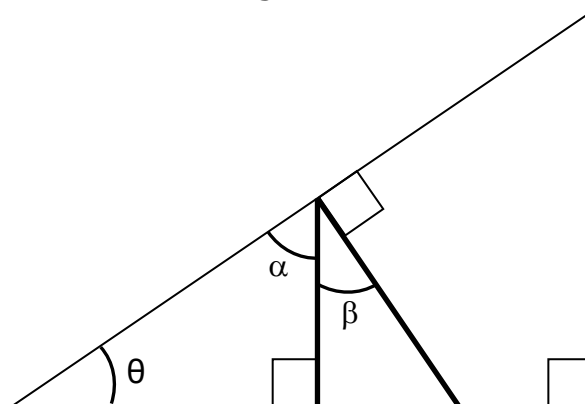

Figure 03

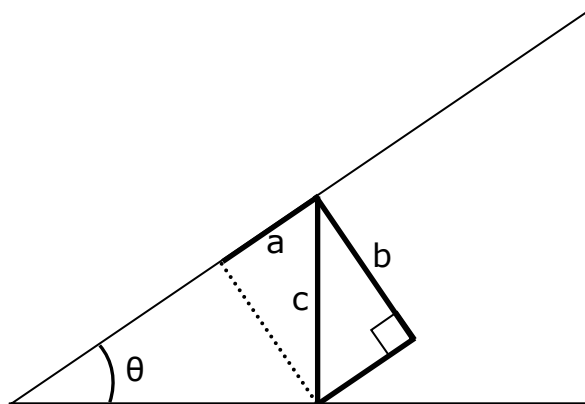

Figure 04

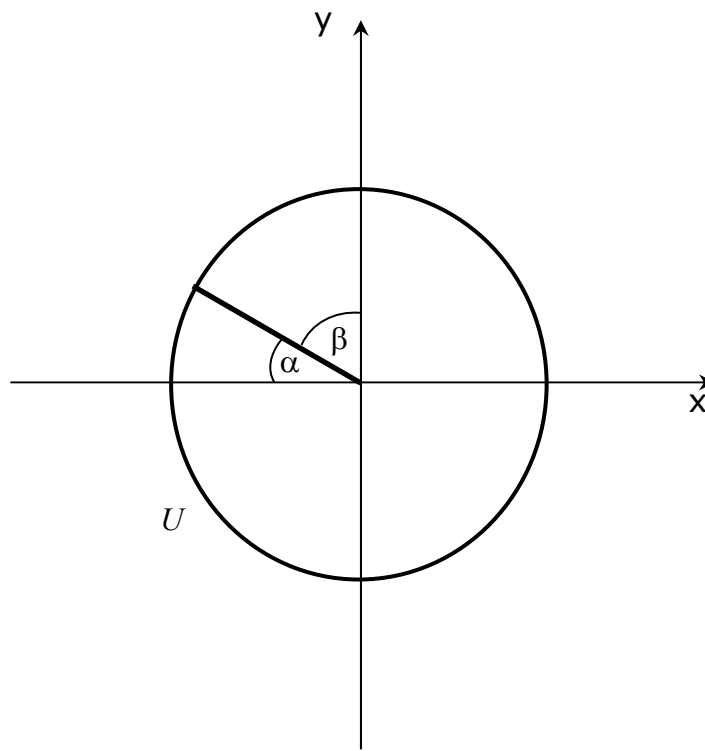

Figure 05

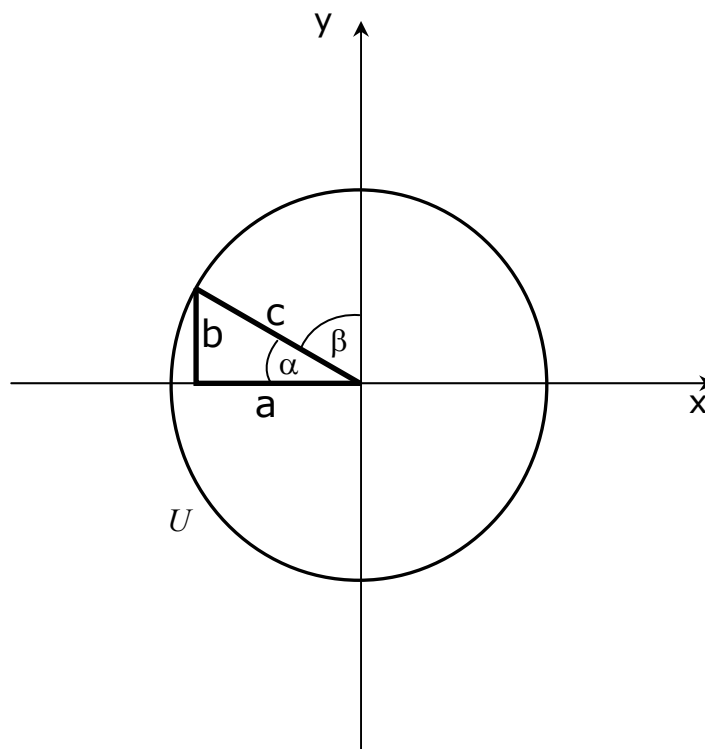

Figure 06

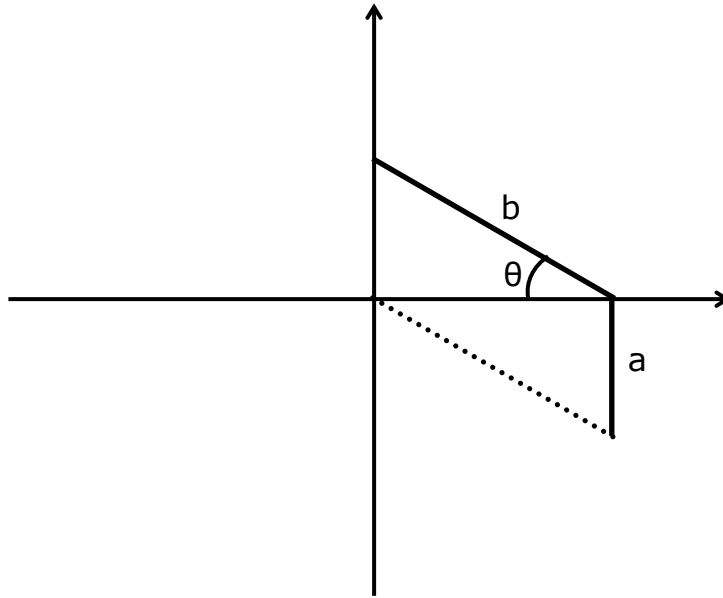

Figure 07

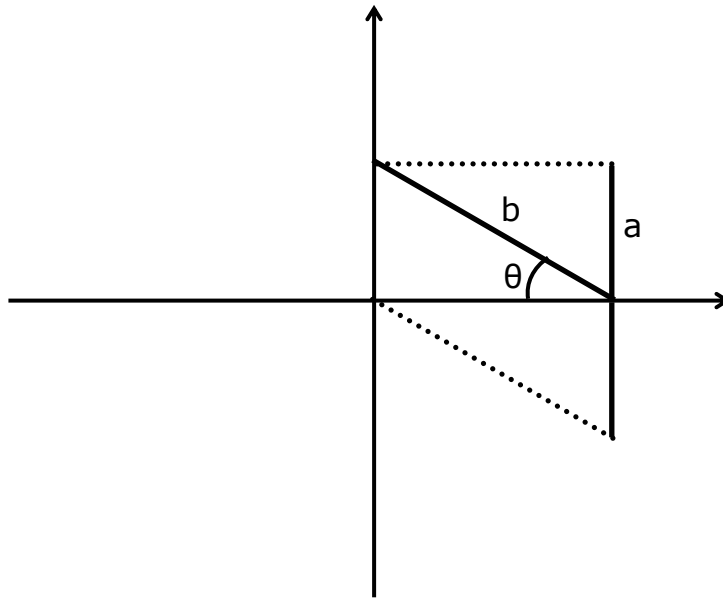
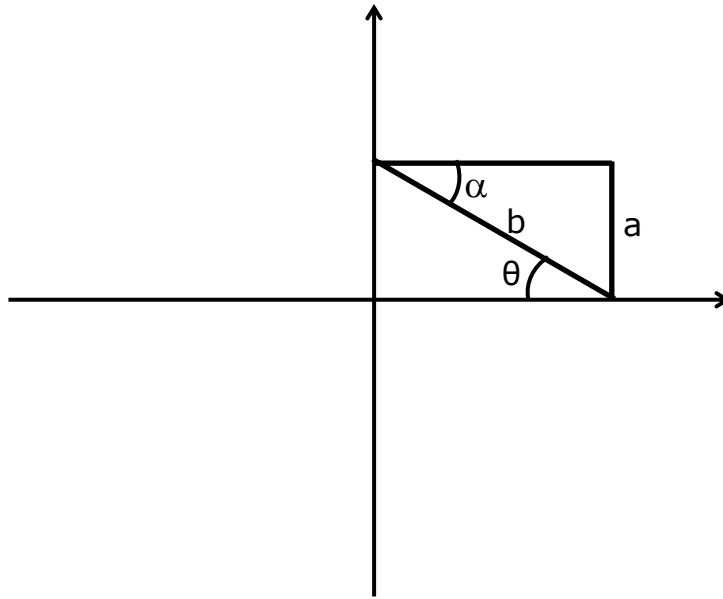

Figure 08



APPENDIX I THIRD INTERVIEW

I.1 PROTOCOL (PILOT-TEST)

Name: _____	_____, 2003	Time In ~ ____ : ____ m
I. D. # _____		Time Out ~ ____ : ____ m
Unit Circle/Function & Vibrations/Waves		
Post-Instruction & Post-Testing		

I (Handout Equation Sheet) Please look at the equation sheet so that you become familiar with the equations.

____ : ____ m

I (Start Tape) Today you will solve questions based on the concepts of vibrations and waves. During your explanation of the solutions, please try to say your thoughts and actions verbally. If it helps to explain your solution, specify your thoughts and/or actions by pointing to the figure. Write everything you possibly can on your paper without erasing. I will be taking notes throughout the interview, so please do not become distracted by my writing (for example the notes may be my explanation of you pointing to an angle on the figure which is something the audio tape cannot pick-up). I may be asking follow-up questions on what you wrote, even if what you wrote is correct or incorrect.

____ : ____ m

I (Handout Question 01) Please read Question 01 and let me know when you are finished reading.

I Okay, you may begin explaining your solution to Question 01.

<input type="checkbox"/> Difficulty with amplitude 'A'.		<input type="checkbox"/> No Difficulty
<input type="checkbox"/> Handout (Equation 01)		
<input type="checkbox"/> Please look at Equation 01 and let me know when you are finished.		
<input type="checkbox"/> What is the amplitude?		
<input type="checkbox"/> Why?		
<input type="checkbox"/> Now try to solve Question 01 part a.	<input type="checkbox"/> Continued Difficulty with amplitude 'A'	<input type="checkbox"/> No Difficulty
	<input type="checkbox"/> What is the maximum value ' $\cos(b t)$ ' of an angle can have?	
<input type="checkbox"/> Now try to solve Question 01 part a.	<input type="checkbox"/> Further Difficulty with amplitude 'A'	<input type="checkbox"/> No Difficulty
	<input type="checkbox"/> What is the maximum value ' x ' can have?	
<input type="checkbox"/> Why?		
<input type="checkbox"/> Now try to solve Question 01 part a.		
<input type="checkbox"/> Did anything at all about Equation 01 prompt you to solve Question 01 part a? If so, what?		

<input type="checkbox"/> Difficulty with angular frequency ' ω '	<input type="checkbox"/> No Difficulty
<input type="checkbox"/> Please look at Equation 01 and let me know when you are finished.	
<input type="checkbox"/> What does 'b' represent? <input type="checkbox"/> Why?	
<input type="checkbox"/> What are the units of 'b'? <input type="checkbox"/> Why?	
<input type="checkbox"/> Is there a relationship between 'b' and the angular frequency ' ω '? <input type="checkbox"/> Why?	
<input type="checkbox"/> What is the general form for the equation of simple harmonic motion? <input type="checkbox"/> Why?	
<input type="checkbox"/> Now try to solve Question 01 part b.	
<input type="checkbox"/> Did anything at all about Equation 01 prompt you to solve Question 01 part b? If so, what?	

<input type="checkbox"/> Difficulty with units of whatever is in the ' $\cos(\dots)$ '	<input type="checkbox"/> No Difficulty
<input type="checkbox"/> Please look at Equation 01 and let me know when you are finished.	
<input type="checkbox"/> What are the units of 'b'? <input type="checkbox"/> Why?	
<input type="checkbox"/> What are the units of 't'? <input type="checkbox"/> Why?	
<input type="checkbox"/> What are the units of the product of 'bt'? <input type="checkbox"/> Why?	
<input type="checkbox"/> Now try to solve Question 01 part c.	
<input type="checkbox"/> Did anything at all about Equation 01 prompt you to solve Question 01 part c? If so, what?	

<input type="checkbox"/> Difficulty with 'displacement at $t = 0.3$ seconds'	<input type="checkbox"/> No Difficulty
<input type="checkbox"/> What does 'x' represent in the equation $x = 0.4 \cos (6.28 t)$?	
<input type="checkbox"/> Now try to solve Question 01 part d.	

<input type="checkbox"/> Difficulty with graph of 'x vs. t'		<input type="checkbox"/> No Difficulty
<input type="checkbox"/> At what values of 't' would 'x' be zero? <input type="checkbox"/> Why?		
<input type="checkbox"/> Now try to solve Question 01 part e.	<input type="checkbox"/> Continued Difficulty with graph of 'x vs. t'	
	<input type="checkbox"/> Solve the equation $x = 0.4 \cos (6.28 t)$ for all values of 't' when $x = 0$ m. <input type="checkbox"/> Why?	
<input type="checkbox"/> Continued Difficulty with graph of 'x vs. t'		<input type="checkbox"/> No Difficulty
<input type="checkbox"/> At what values of 't' would 'x' be maximum? <input type="checkbox"/> Why?		
<input type="checkbox"/> Now try to solve Question 01 part e.	<input type="checkbox"/> Continued Difficulty with graph of 'x vs. t'	
	<input type="checkbox"/> What is the maximum possible value of 'x'?	
	<input type="checkbox"/> Solve the equation $x = 0.4 \cos (6.28 t)$ for all values of 't' when $x = 0.4$ m.	
<input type="checkbox"/> Continued Difficulty with graph of 'x vs. t'		<input type="checkbox"/> No Difficulty
<input type="checkbox"/> At what values of 't' would 'x' be minimum? <input type="checkbox"/> Why?		
<input type="checkbox"/> Now try to solve Question 01 part e.	<input type="checkbox"/> Continued Difficulty with graph of 'x vs. t'	
	<input type="checkbox"/> What is the minimum possible value of 'x'?	
	<input type="checkbox"/> Solve the equation $x = 0.4 \cos (6.28 t)$ for all values of 't' when $x = -0.4$ m.	

<input type="checkbox"/> Difficulty with 'reference circle'		<input type="checkbox"/> No Difficulty
<input type="checkbox"/> Draw y vs. x coordinate system. <input type="checkbox"/> Now complete the reference circle for part f.		
	<input type="checkbox"/> Continued Difficulty with 'reference circle'	
	<input type="checkbox"/> Draw a circle on the y vs. x coordinate system.	
	<input type="checkbox"/> Now complete the reference circle for part f.	
<input type="checkbox"/> When $t = 0$ seconds, where is the object located? <input type="checkbox"/> Why?		
<input type="checkbox"/> What can you associate the 0.4 in the equation $x = 0.4 \cos (6.28 t)$ with in the reference circle? <input type="checkbox"/> Why?		
<input type="checkbox"/> What can you associate the 6.28 in the equation $x = 0.4 \cos (6.28 t)$ with in the reference circle? <input type="checkbox"/> Why?		
<input type="checkbox"/> Now complete the reference circle.	<input type="checkbox"/> Further Difficulty with 'reference circle'	
	<input type="checkbox"/> No Difficulty	
	<input type="checkbox"/> Place a point on the circle '2' and the points' projection along the y '1' and x '3' axis.	
	<input type="checkbox"/> What point '1', '2', or '3' is related to the motion of the object? <input type="checkbox"/> Why?	

(After 20 minutes) We have an additional question to look at today, so we will leave this question and come back to Question 01 if there is time left at the end.

____:____m

I (Handout Question 02) Please read Question 02 and let me know when you are finished reading.

I Okay, you may begin explaining your solution to Question 02.

<input type="checkbox"/> Difficulty with amplitude 'A'	<input type="checkbox"/> No Difficulty
<input type="checkbox"/> What is the maximum value 'x' can have?	
<input type="checkbox"/> Why?	
<input type="checkbox"/> Now try to solve Question 02 part a.	

<input type="checkbox"/> Difficulty with period 'T'	<input type="checkbox"/> No Difficulty
<input type="checkbox"/> Over what duration of time does the graph repeat itself?	
<input type="checkbox"/> Why?	
<input type="checkbox"/> Now try to solve Question 02 part b.	

<input type="checkbox"/> Difficulty with frequency 'f'	<input type="checkbox"/> No Difficulty
<input type="checkbox"/> What is the relationship between the period 'T' and the frequency 'f'?	
<input type="checkbox"/> Why?	
<input type="checkbox"/> Now try to solve Question 02 part c.	

<input type="checkbox"/> Difficulty with angular frequency ' ω '	<input type="checkbox"/> No Difficulty
<input type="checkbox"/> What is the relationship between angular frequency ' ω ' and period 'T' or frequency 'f'?	
<input type="checkbox"/> Why?	
<input type="checkbox"/> Now try to solve Question 02 part d.	

<input type="checkbox"/> Difficulty with 'displacement at $t = 0.2$ seconds'	<input type="checkbox"/> No Difficulty
<input type="checkbox"/> According to the graph given in the question, what is displacement?	
<input type="checkbox"/> Now try to solve Question 02 part e.	

<input type="checkbox"/> Difficulty with 'equation of motion of the vibrating mass'	<input type="checkbox"/> No Difficulty
<input type="checkbox"/> What is the equation of motion of the vibrating mass in the general form of $x = A \sin(\omega t)$?	

<input type="checkbox"/> Difficulty with 'reference circle'		<input type="checkbox"/> No Difficulty
<input type="checkbox"/> Draw y vs. x coordinate system. <input type="checkbox"/> Now complete the reference circle for part g.		
	<input type="checkbox"/> Continued Difficulty with 'reference circle'	<input type="checkbox"/> No Difficulty
	<input type="checkbox"/> Draw a circle on the y vs. x coordinate system. <input type="checkbox"/> Now complete the reference circle for part g.	
<input type="checkbox"/> When $t = 0$ seconds, where is the object located? <input type="checkbox"/> Why?		
<input type="checkbox"/> What can you associate the amplitude of the graph with in the reference circle? <input type="checkbox"/> Why?		
<input type="checkbox"/> What can you associate the period of the graph with in the reference circle? <input type="checkbox"/> Why?		
<input type="checkbox"/> Now complete the reference circle.	<input type="checkbox"/> Further Difficulty with 'reference circle'	<input type="checkbox"/> No Difficulty
	<input type="checkbox"/> Place a point on the circle '2' and the points' projection along the y '1' and x '3' axis. <input type="checkbox"/> What point '1', '2', or '3' is related to the motion of the object? <input type="checkbox"/> Why?	
<input type="checkbox"/> (After 20 minutes)		

I.2 EQUATION SHEET (PILOT-TEST)

Equations

$$f = \frac{1}{T}$$

$$\omega = 2 \pi f$$

$$x = A \cos (\omega t) \quad \& \quad x = A \sin (\omega t)$$

I.3 QUESTIONS (PILOT-TEST)

Question 01

A 0.50-kg mass vibrates according to the equation: $x = 0.40 \cos(6.28 t)$, where x is in meters, and t in seconds.

- Determine the amplitude, A .
- Determine the angular frequency, ω .
- What are the units of the product of whatever is inside the $\cos(\dots)$?
- What is the displacement at $t = 0.3$ seconds?
- Graph the equation of x vs. t showing correct amplitude and period.
- Represent the equation $x = 0.40 \cos(6.28 t)$ in terms of a reference circle?

Question 02

A 0.400-kg mass vibrates according to the following graph of x vs. t .

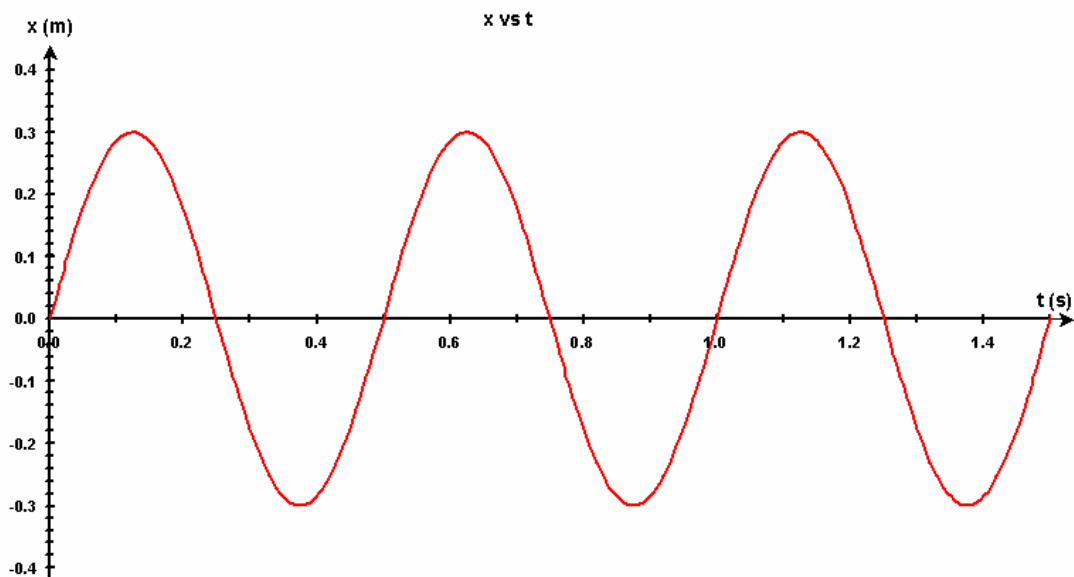

- Determine the amplitude, A .
- Determine the period, T .
- Determine the frequency, f .
- Determine the angular frequency, ω .
- What is the displacement at $t = 0.2$ seconds?
- Write the equation of motion of the vibrating mass.
- Represent the graph in terms of a reference circle?

- h. Suppose the graph (**Graph h1**) is shifted so the point (P_1) is at the origin (see **Graph h2**), what is the new equation of motion representing the graph (**Graph h2**)?

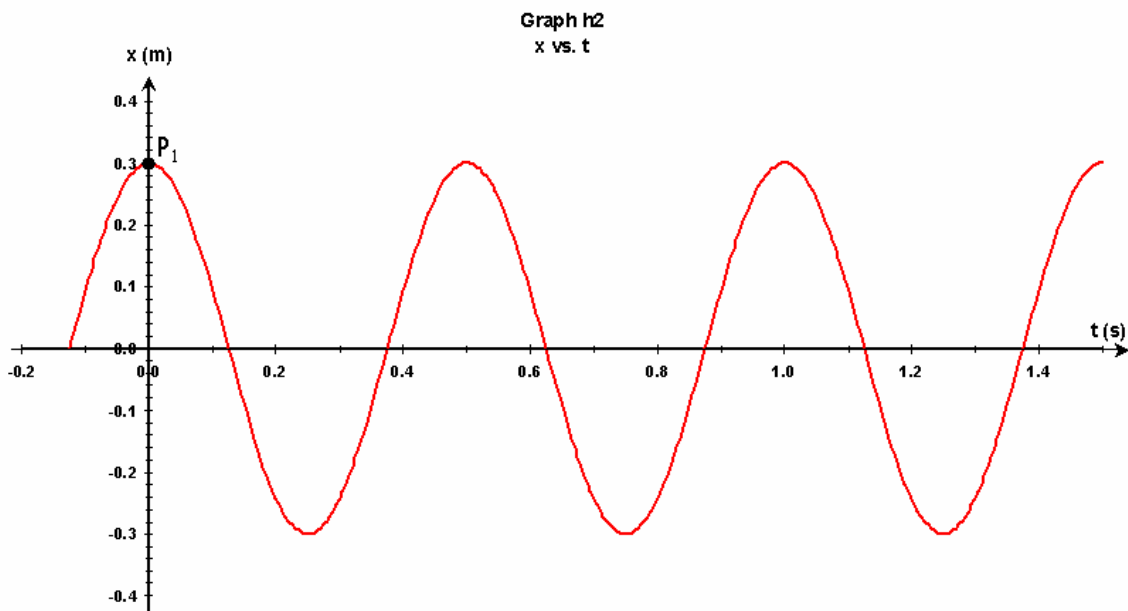
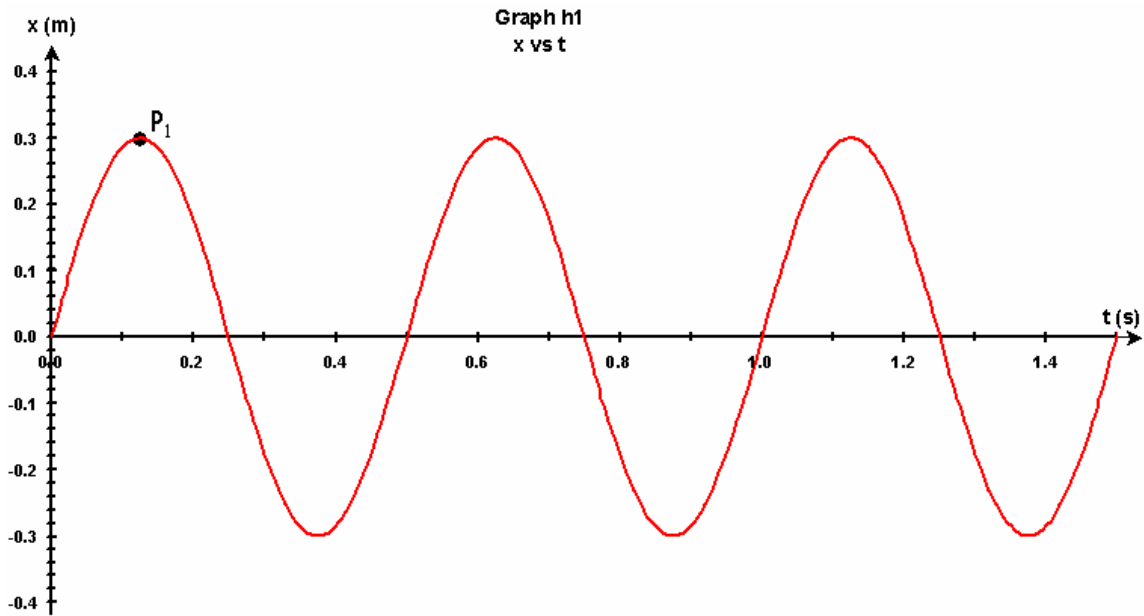

I.4 EQUATION 01 (PILOT-TEST)

Equation 01

$$x = a \cos (b t)$$

I.5 PROTOCOL

Name: _____	_____, 2003	Time In ~ ____ : ____ m
I. D. # _____		Time Out ~ ____ : ____ m
Unit Circle/Function & Vibrations/Waves		
Post-Instruction & Post-Testing		

I (Handout Equation Sheet) Please look at the equation sheet so that you become familiar with the equations.

____ : ____ m

I (Start Tape) Today you will solve questions based on the concepts of vibrations and waves. During your explanation of the solutions, please try to say your thoughts and actions verbally. If it helps to explain your solution, specify your thoughts and/or actions by pointing to the figure. Write everything you possibly can on your paper without erasing. I will be taking notes throughout the interview, so please do not become distracted by my writing (for example the notes may be my explanation of you pointing to an angle on the figure which is something the audio tape cannot pick-up). I may be asking follow-up questions on what you wrote, even if what you wrote is correct or incorrect.

____ : ____ m

I (Handout Question 01) Please read Question 01 and let me know when you are finished reading.

I Once you answer a certain part of Question 01, I have some additional questions for you before you move on to the next part. You may begin explaining your solution to Question 01 part a.

<input type="checkbox"/> Difficulty with amplitude 'A'		<input type="checkbox"/> No Difficulty
<input type="checkbox"/> Handout (Equation 01) Please look at Equation 01 and let me know when you are finished.		
<input type="checkbox"/> What is the amplitude?		
<input type="checkbox"/> Why?		
<input type="checkbox"/> Now try to solve Question 01 part a.	<input type="checkbox"/> Continued Difficulty with amplitude 'A'	<input type="checkbox"/> No Difficulty
	<input type="checkbox"/> What is the maximum value ' $\cos(b t)$ ' of an angle can have?	
<input type="checkbox"/> Why?		
<input type="checkbox"/> Now try to solve Question 01 part a.	<input type="checkbox"/> Further Difficulty with amplitude 'A'	<input type="checkbox"/> No Difficulty
	<input type="checkbox"/> What is the maximum value ' x ' can have?	
<input type="checkbox"/> Why?		
<input type="checkbox"/> Now try to solve Question 01 part a.		
<input type="checkbox"/> Did anything at all about Equation 01 prompt you to solve Question 01 part a? If so, what?		

<input type="checkbox"/> Difficulty with angular frequency ' ω '	<input type="checkbox"/> No Difficulty
<input type="checkbox"/> Please look at Equation 01 and let me know when you are finished.	
<input type="checkbox"/> What does 'b' represent? <input type="checkbox"/> Why?	
<input type="checkbox"/> What are the units of 'b'? <input type="checkbox"/> Why?	
<input type="checkbox"/> Is there a relationship between 'b' and the angular frequency ' ω '? <input type="checkbox"/> Why?	
<input type="checkbox"/> What is the general form for the equation of simple harmonic motion? <input type="checkbox"/> Why?	
<input type="checkbox"/> Now try to solve Question 01 part b.	
<input type="checkbox"/> Did anything at all about Equation 01 prompt you to solve Question 01 part b? If so, what?	

<input type="checkbox"/> Difficulty with units of whatever is in the ' $\cos(\dots)$ '	<input type="checkbox"/> No Difficulty
<input type="checkbox"/> Please look at Equation 01 and let me know when you are finished.	
<input type="checkbox"/> What are the units of 'b'? <input type="checkbox"/> Why?	
<input type="checkbox"/> What are the units of 't'? <input type="checkbox"/> Why?	
<input type="checkbox"/> What are the units of the product of 'bt'? <input type="checkbox"/> Why?	
<input type="checkbox"/> Now try to solve Question 01 part c.	
<input type="checkbox"/> Did anything at all about Equation 01 prompt you to solve Question 01 part c? If so, what?	

<input type="checkbox"/> Difficulty with 'displacement at $t = 0.3$ seconds'	<input type="checkbox"/> No Difficulty
<input type="checkbox"/> What does 'x' represent in the equation $x = 0.4 \cos (6.28 t)$?	
<input type="checkbox"/> Now try to solve Question 01 part d.	

<input type="checkbox"/> Difficulty with graph of 'x vs. t'		<input type="checkbox"/> No Difficulty
<input type="checkbox"/> At what values of 't' would 'x' be zero? <input type="checkbox"/> Why?		
<input type="checkbox"/> Now try to solve Question 01 part e.	<input type="checkbox"/> Continued Difficulty with graph of 'x vs. t'	
	<input type="checkbox"/> Solve the equation $x = 0.4 \cos (6.28 t)$ for all values of 't' when $x = 0$ m. <input type="checkbox"/> Why?	
<input type="checkbox"/> Continued Difficulty with graph of 'x vs. t'		<input type="checkbox"/> No Difficulty
<input type="checkbox"/> At what values of 't' would 'x' be maximum? <input type="checkbox"/> Why?		
<input type="checkbox"/> Now try to solve Question 01 part e.	<input type="checkbox"/> Continued Difficulty with graph of 'x vs. t'	
	<input type="checkbox"/> What is the maximum possible value of 'x'?	
	<input type="checkbox"/> Solve the equation $x = 0.4 \cos (6.28 t)$ for all values of 't' when $x = 0.4$ m.	
<input type="checkbox"/> Continued Difficulty with graph of 'x vs. t'		<input type="checkbox"/> No Difficulty
<input type="checkbox"/> At what values of 't' would 'x' be minimum? <input type="checkbox"/> Why?		
<input type="checkbox"/> Now try to solve Question 01 part e.	<input type="checkbox"/> Continued Difficulty with graph of 'x vs. t'	
	<input type="checkbox"/> What is the minimum possible value of 'x'?	
	<input type="checkbox"/> Solve the equation $x = 0.4 \cos (6.28 t)$ for all values of 't' when $x = -0.4$ m.	

<input type="checkbox"/> Difficulty with 'reference circle'		<input type="checkbox"/> No Difficulty
<input type="checkbox"/> Draw y vs. x coordinate system. <input type="checkbox"/> Now complete the reference circle for part f.		
	<input type="checkbox"/> Continued Difficulty with 'reference circle'	
	<input type="checkbox"/> Draw a circle on the y vs. x coordinate system.	
	<input type="checkbox"/> Now complete the reference circle for part f.	
<input type="checkbox"/> When $t = 0$ seconds, where is the object located? <input type="checkbox"/> Why?		
<input type="checkbox"/> In the equation $x = 0.4 \cos (6.28 t)$, what can you associate the 0.4 with in the reference circle? <input type="checkbox"/> Why?		
<input type="checkbox"/> In the equation $x = 0.4 \cos (6.28 t)$, what can you associate the 6.28 with in the reference circle? <input type="checkbox"/> Why?		
<input type="checkbox"/> Now complete the reference circle.	<input type="checkbox"/> Further Difficulty with 'reference circle'	
	<input type="checkbox"/> No Difficulty	
	<input type="checkbox"/> Place a point on the circle 'P _o ' (the object) and the objects' projection along the y -axis 'P _y ' and along the x -axis 'P _x '.	
	<input type="checkbox"/> What point 'P _o ', 'P _y ', or 'P _x ' is related to the motion of the object? <input type="checkbox"/> Why?	

(After 20 minutes) We have an additional question to look at today, so we will leave this question and come back to Question 01 if there is time left at the end.

____:____m

- I (Handout Question 02) Please read Question 02 and let me know when you are finished reading.
- I Once you answer a certain part of Question 02, I have some additional questions for you before you move on to the next part. You may begin explaining your solution to Question 02 part a.

<input type="checkbox"/> Difficulty with amplitude 'A'	<input type="checkbox"/> No Difficulty
<input type="checkbox"/> What is the maximum value 'x' can have? <input type="checkbox"/> Why?	
<input type="checkbox"/> Now try to solve Question 02 part a.	

<input type="checkbox"/> Difficulty with period 'T'	<input type="checkbox"/> No Difficulty
<input type="checkbox"/> Over what duration of time does the graph repeat itself? <input type="checkbox"/> Why?	
<input type="checkbox"/> Now try to solve Question 02 part b.	

<input type="checkbox"/> Difficulty with frequency 'f'	<input type="checkbox"/> No Difficulty
<input type="checkbox"/> What is the relationship between the period 'T' and the frequency 'f'? <input type="checkbox"/> Why?	
<input type="checkbox"/> Now try to solve Question 02 part c.	

<input type="checkbox"/> Difficulty with angular frequency ' ω '	<input type="checkbox"/> No Difficulty
<input type="checkbox"/> What is the relationship between angular frequency ' ω ' and period 'T' or frequency 'f'? <input type="checkbox"/> Why?	
<input type="checkbox"/> Now try to solve Question 02 part d.	

<input type="checkbox"/> Difficulty with 'displacement at $t = 0.2$ seconds'	<input type="checkbox"/> No Difficulty
<input type="checkbox"/> According to the graph given in the question, what is displacement?	
<input type="checkbox"/> Now try to solve Question 02 part e.	

<input type="checkbox"/> Difficulty with 'equation of motion of the vibrating mass'	<input type="checkbox"/> No Difficulty
<input type="checkbox"/> What is the equation of motion of the vibrating mass in the general form of $x = A \sin(\omega t)$?	

<input type="checkbox"/> Difficulty with 'reference circle'		<input type="checkbox"/> No Difficulty
<input type="checkbox"/> Draw y vs. x coordinate system. <input type="checkbox"/> Now complete the reference circle for part g.		
	<input type="checkbox"/> Continued Difficulty with 'reference circle'	<input type="checkbox"/> No Difficulty
	<input type="checkbox"/> Draw a circle on the y vs. x coordinate system. <input type="checkbox"/> Now complete the reference circle for part g.	
<input type="checkbox"/> When $t = 0$ seconds, where is the object located? <input type="checkbox"/> Why?		
<input type="checkbox"/> What can you associate the amplitude of the graph with in the reference circle? <input type="checkbox"/> Why?		
<input type="checkbox"/> What can you associate the period of the graph with in the reference circle? <input type="checkbox"/> Why?		
<input type="checkbox"/> Now complete the reference circle.	<input type="checkbox"/> Further Difficulty with 'reference circle'	<input type="checkbox"/> No Difficulty
	<input type="checkbox"/> Place a point on the circle ' P_o ' (the object) and the objects' projection along the y -axis ' P_y ' and along the x -axis ' P_x '. <input type="checkbox"/> What point ' P_o ', ' P_y ', or ' P_x ' is related to the motion of the object? <input type="checkbox"/> Why?	
<input type="checkbox"/> (After 20 minutes)		

I.6 EQUATION SHEET

Equations

$$f = \frac{1}{T}$$

$$\omega = 2 \pi f$$

$$x = A \cos (\omega t) \quad \& \quad x = A \sin (\omega t)$$

I.7 QUESTIONS

Question 01

A 0.50-kg mass vibrates according to the equation $x = 0.40 \cos(6.28 t)$, where x is in meters, and t in seconds.

- Determine the amplitude 'A'.
- Determine the angular frequency ' ω '.
- What are the units of the product of whatever is inside the ' $\cos(\dots)$ ' ?
- What is the displacement at $t = 0.3$ seconds?
- Graph the equation of x vs. t showing correct amplitude 'A' and period 'T'.
- Represent the equation $x = 0.40 \cos(6.28 t)$ in terms of a reference circle?

Question 02

A 0.400-kg mass vibrates according to the following graph of x vs. t .

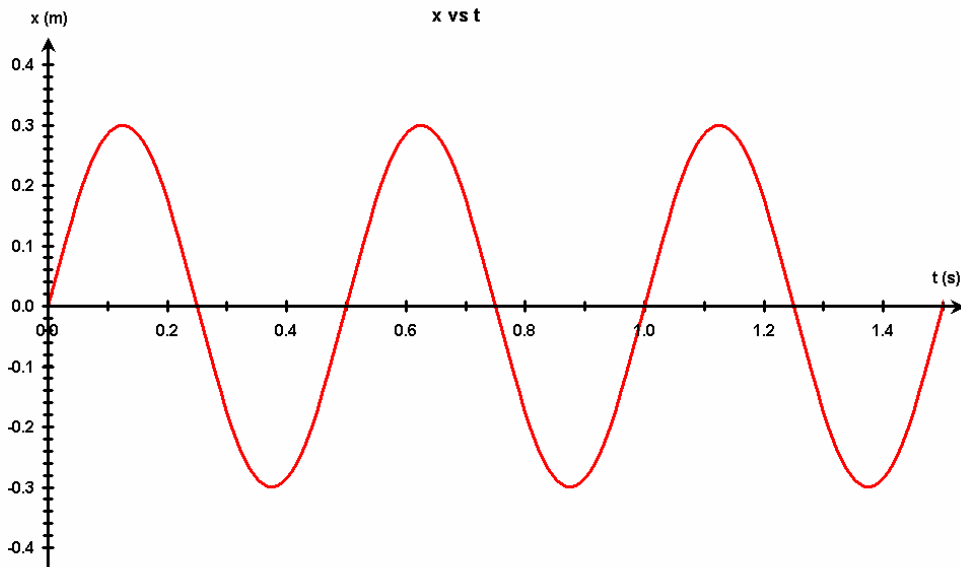

- Determine the amplitude 'A'.
- Determine the period 'T'.
- Determine the frequency 'f'.
- Determine the angular frequency ' ω '.
- What is the displacement at $t = 0.2$ seconds?
- Write the equation of motion of the vibrating mass.
- Represent the graph in terms of a reference circle?

- h. Suppose the graph (**Graph H1**) is shifted so the point (**P₁**) is at the origin (see **Graph H2**), what is the new equation of motion representing the graph (**Graph H2**)?

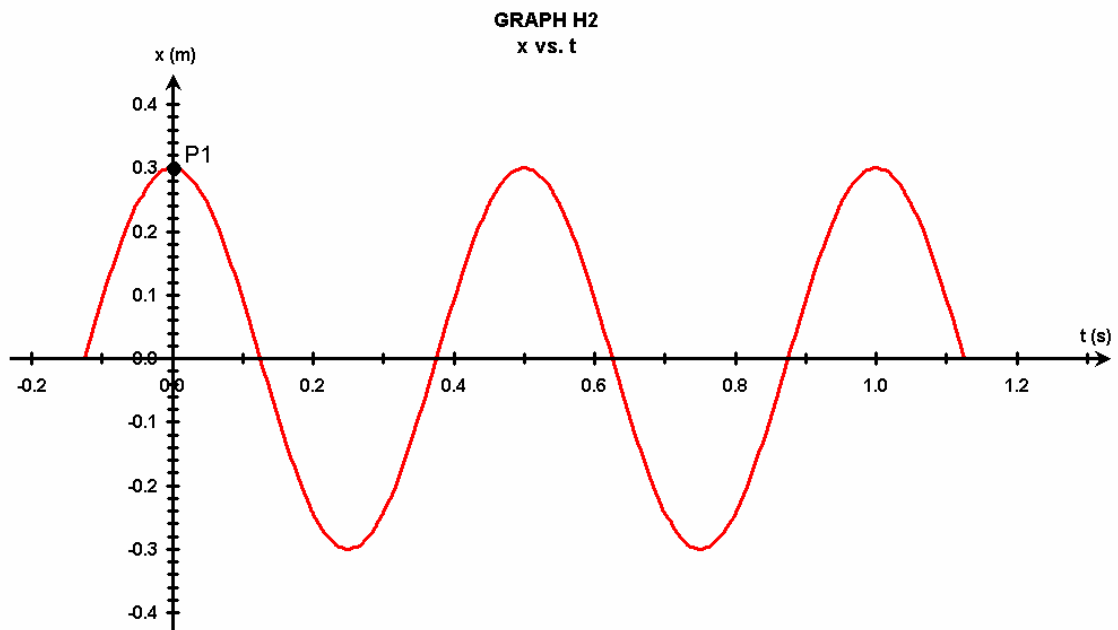
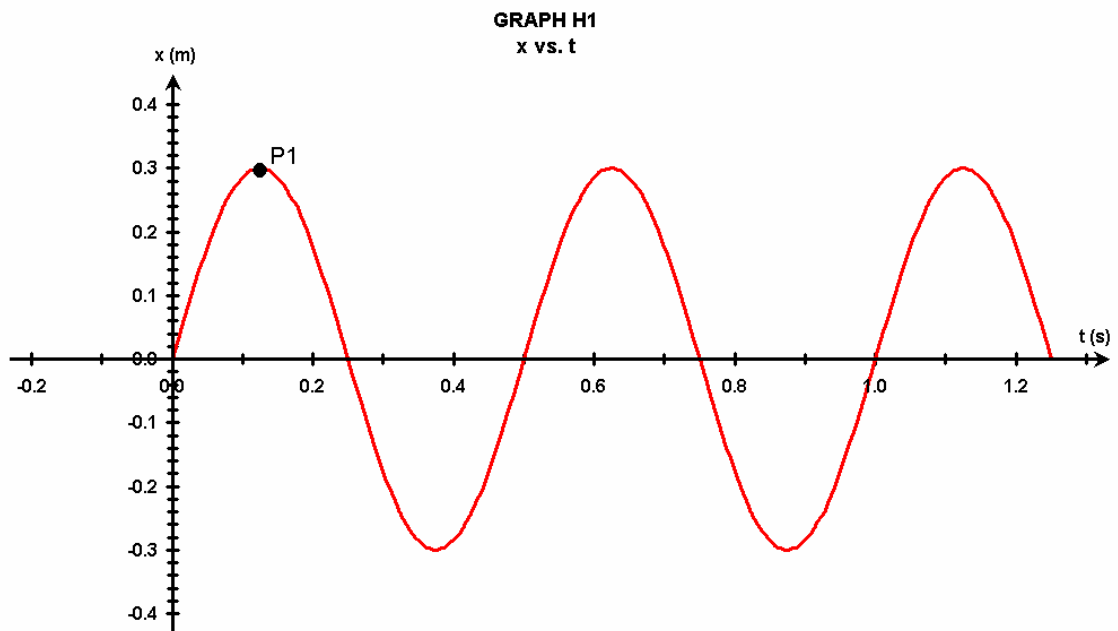

I.8 EQUATION 01

Equation 01

$$x = a \cos (b t)$$