

## THE HUMAN EYE AND VISION

Dyan McBride

Based on similar lessons developed by the Hartmut Wiesner & Physics Education Group, LMU Munich

Our most important sense organ is the eye; in general we receive more than 80% of our information about our environment from seeing. Thus, for us “proper” seeing is of utmost importance.

For us to be able to see an object, light from that object must enter our eyes. That means that the surface of the object must be stimulated to emit light. This could happen with a lamp, candle, the sun, or other sources in which the object rises to a high temperature and the atomic particles vibrate and thereby emit electromagnetic waves. Light is an electromagnetic wave. The light which enters the eye is converted by the retina into electrical impulses. These signals are transmitted to the brain where they are analyzed and interpreted.

### A Quick Review of Waves

As we said earlier, light is an electromagnetic wave. Because it is an electromagnetic wave, light is self-propagating – it does not need a medium. A basic wave can be seen below. The amplitude (A) and wavelength ( $\lambda$ ) of light are both very important characteristics – they are illustrated on the simple drawing below. The wavelength of light is what determines the colour we see, and the amplitude determines how bright the light is.

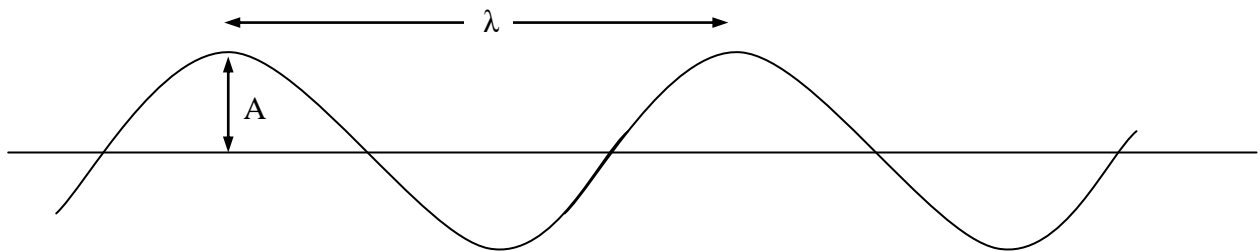

### Modeling the Eye as an Optical System

In this section, we will look at ways to create models of the eye. As with many models in science, we will start with a relatively simple one and then build upon it to match reality. Along the way, we will find that some animals in nature have evolved to have eyes that are similar to each of the models. These eyes can be very different, but have one thing in common: eyes in all animals bring light into an object that is approximately a sphere, and the light falls on a detector which converts the light into signals which are sent to the brain to be interpreted.

To model these eyes, we will use a hollow Styrofoam ball as a foundation. On one side of the ball, we cut an opening and cover it with semi-transparent paper or plastic. This area represents the *retina*, or the place where the image falls and is converted into electrical signals in the real eye. For our purposes, we will just observe images on this “retina” to see how they would appear before being converted.



### *The Simplest Eye*

- ◆ For the first model, cut a small hole about 1cm in diameter on the side directly opposite the retina. We will call this hole the *pupil*.
- ? Describe the light you see on the retina.

As you can see, the light which reaches the retina in this case is not an image but just a spot of light.

- ◆? To create the first image, use a piece of black paper with a very small hole in it. Place this paper over the pupil and describe what you see.

An eye similar to this model is called a pinhole eye. This type of eye is the simplest of all eyes, and exists in some sea animals such as the cephalopod called the Nautilus. (Image from <http://www.weichtiere.at/Kopffuesser/nautilus.html>) The eye is the circular object located in the center of the image.

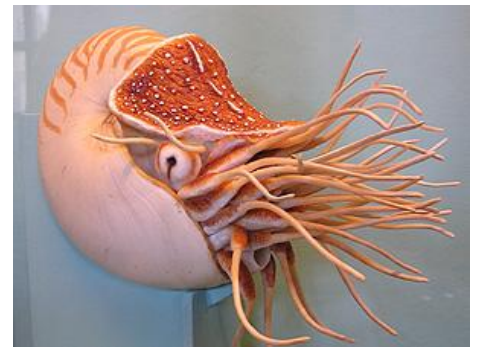

The origin of the image created by the nautilus' eye is relatively easy to understand. A ray of light goes straight through the small opening and creates a point of light on the retina. The figure below shows two such points representing the surface. From this representation, we can see immediately that the image is both inverted (upside down) and reversed. These images are also made by pinhole cameras.

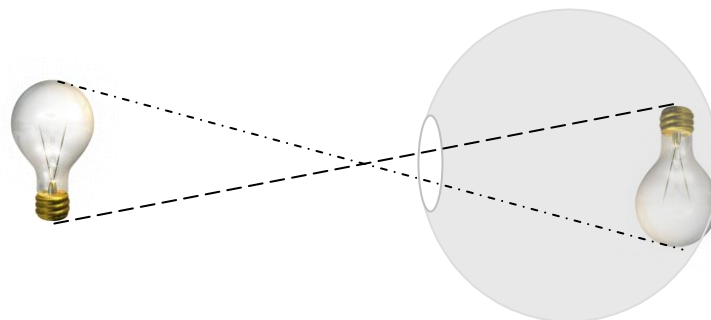

- ◆? Now vary the size of the opening in the paper and describe how the image changes.

As you saw in the experiment, the image in a pinhole camera or eye is very faint. In order to make it brighter, we must increase the size of the opening. Then, the light rays are not so constrained in their paths. However the images from different sets of rays overlap, and so the image becomes less sharp, as seen in the figure below. So, the smaller the image is, the dimmer but sharper the image is.

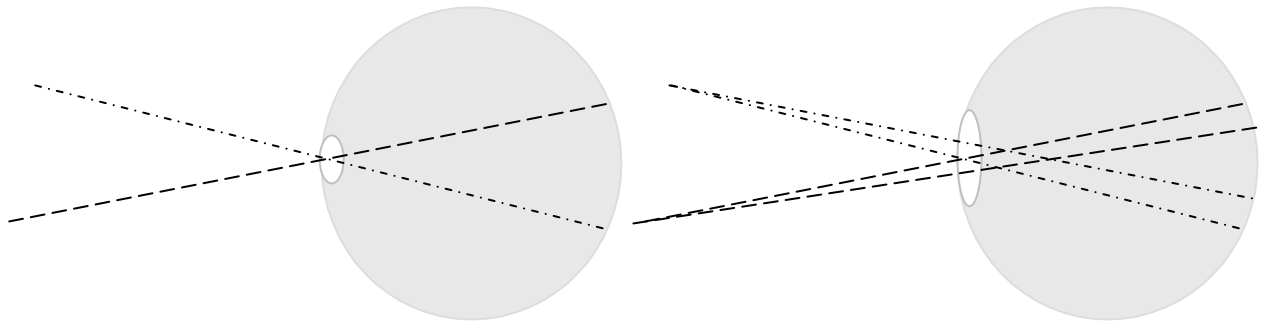

Pinhole eyes work well for animals that only need limited vision. However, the limitations we saw above make it inadequate for humans.

For an image that is both bright *and* sharply focused, we must have a somewhat large opening. As light passes through this opening, the light rays need to be gathered in such a way that they create a sharply focused image.

### ***A more complex (and realistic) eye model***

To obtain both a large opening and focusing, we require a lens, which most animal and human eyes have. Thus, to improve our model, we need to add lenses.

◆ Remove the black paper from the eye and replace it with a single converging (also called convex) lens.

? Describe the image on the retina.

? Now point the eye model at images that are much different distances – both very near and very far -- from the eye. Describe how the image changes with distance.

### **How a converging lens creates an image**

◆ To explore image creation with lenses, start the “Optik” simulation, and choose “Light Rays Through Lenses.” To investigate what happens with light, we have selected only two points. Light from these points goes in all possible directions. However, only two light rays which fall on the lens are represented. (Of course, the light traveling away in other directions

can contribute nothing to the image formed on the retina). The lens changes the light direction in such a way that the light gathers behind the lens. If we place a screen (with the eye this would be the retina) at the proper locations, then we observe on the screen both images of the object. If we shift the screen, the points become indistinct or blurry. In order to have a sharp image, we can either shift the screen or use a different lens.

◆? Explore by placing the object at different distances away from the lens, and attempting to get them in focus by moving the screen. Is it possible to focus on object very near to the lens? Very far from the lens?

? The place where the image can be clearly seen is called the focal point of a lens. What factors determine where the focal point of a lens will be?

### Accommodation – varying the range of vision

As you can see, the converging lens improves the light gathering ability of the eye and can create sharp images on the retina. However, as you see in the model and the simulation, one lens is not sufficient for seeing objects at a broad range of distances. Somehow the eye must change (accommodate) to allow us and other animals to view objects at different distances.

◆ To see one way in which accommodation occurs, you can use the simulation. Click on the arrow in the bottom right corner of the screen to go back to the main menu. This time, chose “Light Rays in the Eye.” Set the object at some small distance from the eye. Then, adjust the lens inside the eye so that the object focuses sharply on the retina. Now move the object slightly so that the image is slightly less than sharp. To bring it back to sharp, move the back of the eye.

As you can see, changing the distance between the lens and the retina can help change the focus of the image. This type of accommodation occurs in some sea animals such as sharks and squid. In this photo from Horn (1982), we can see the eye of a squid with both the relaxed (for average distances) and contracted (for shorter distances) positions of

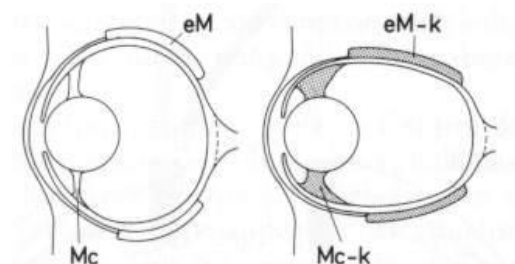

extra-ocular (eM) muscle.

◆? The human eye adapts so that we can see objects at different distance in another way. To see how our eye accommodates, go back to the simulation. Make sure that the “automatic focusing” option is turned off, and hit the “Normal” button to return the shape of the eye to normal. Now change the thickness of the lens a few times. For each thickness, move the object and record your observations about the image. What do you notice about the thickness when the objects are close to the eye? What do you notice when the objects are far from the eye?

As you can see from the simulation, the lens of the human eye needs to change in order to accommodate for objects at different distances. If the lens is made thinner than average in the center, the location of the object for which the image is clear moves away from the eye. If the lens is thickened in the center, the object location for a clear image shifts toward the lens. This remarkable property of the lens to bring together diverging light rays is called its refractive power. With a lens of high refractive power, the object near the lens is clear; with smaller refractive power it is further away.

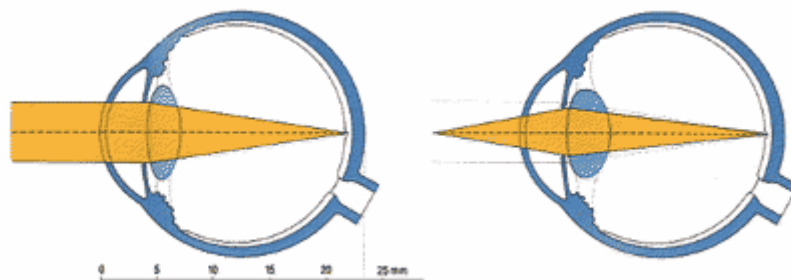

The pictures on the left show a representation the eye accommodating for distance vision; on the right is accommodation for close vision. ([http://www.augen.de/index.php?id=info\\_fehlsichtigkeit](http://www.augen.de/index.php?id=info_fehlsichtigkeit))

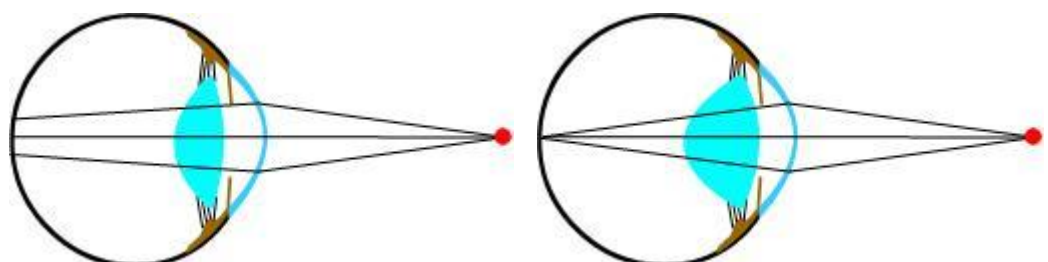

Viewing an object at a set distance (a) without accommodation of the eye lens and (b) with accommodation. (<http://www.blue-eye-divers.ch/index.php?page=10.20> )

As the simulations show, we need a lens in our model so that it represents the human eye. In fact, we need to add a lens that can change its shape. This lens is located slightly behind the fixed lens that you have already installed. By changing its thickness, the eye lens enables us to see objects at a vast range of distances.

## **Anatomy of the Eye**

Let's pause for a moment and look at the anatomy of the eye. The human eye is approximately a sphere with an average radius of about 24 mm. It consists of the following parts

- the cornea, which is scarcely a millimeter thick, has no blood supply of its own and is completely transparent
- the eye chamber, which contains a liquid (aqueous humor)
- the iris, which has a circular hole (pupil) at the center and is the “eye color”
- the flexible accommodating lens, which is attached by a elastic ring of ligaments called the zonula to the ciliary muscle
- the vitreous humour, which fills out the eyeball volume
- the retina, which lines the rear internal surface of the eye and is where the image falls in the eye

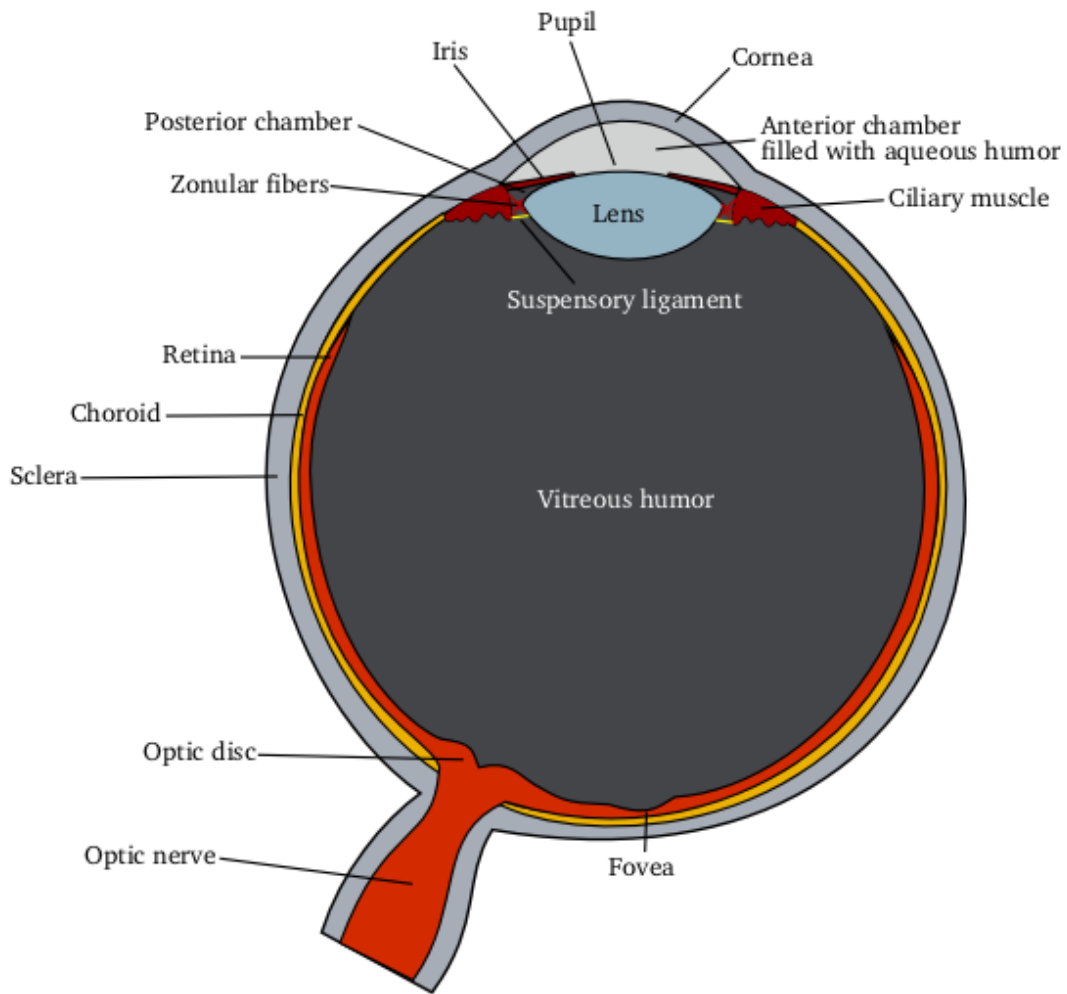

From: <http://en.wikipedia.org/wiki/Eye> & <http://de.wikipedia.org/wiki/Auge>

The visible light must go through the optical apparatus of the eye to be able to stimulate the retina. Just like we saw when using the computer simulation and the eye model, the refracting power can be changed in two ways:

1. by the muscles outside of the eye deforming the whole eye ball, including the cornea, or
2. by the ciliary muscles changing the curvatures of the lenses (accommodation).

**Focus on distant object**  
**orbicular muscle relaxed**  
**lens taut from fascicle of fibres**

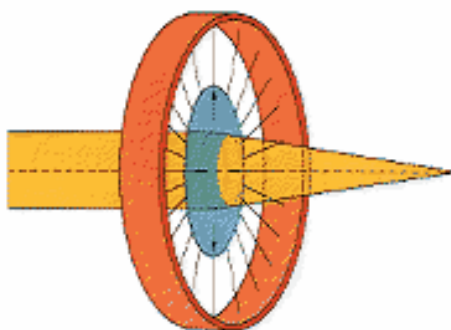

**Focus on near object**  
**orbicular muscle tense**  
**lens relaxed**

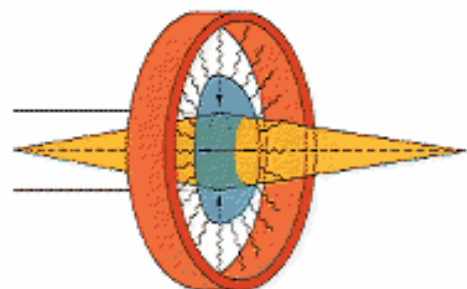

Accommodation: When the ciliary muscles are relaxed the lens becomes thin for looking at distant objects. By becoming tense the muscles cause the lens to become thicker to view close objects. Adapted from [www.augen.de/uploads/RTEmagicC\\_4c78fee701.gif](http://www.augen.de/uploads/RTEmagicC_4c78fee701.gif)

## **Vision Defects**

Most of us have or will have some vision problems. These difficulties in seeing may be minor inconveniences or major shortcomings in our ability to see clearly. They may appear early or late in our lives. Fortunately, many methods from eye glasses and contact lenses to surgery are available to make corrections to our natural optical (ocular) system. However, before eye specialists can make corrections they must know very precisely what the problem is. Most eye defects are limited to three common problems – nearsightedness, farsightedness and astigmatism. We can use the simulation or the eye model to understand the physics behind these vision defects.

### ***Exploring vision defects with the eye model***

◆? To create an eye model with a vision defect, separate the two halves and add a small Styrofoam ring between the halves of the sphere. Make sure that the accommodating lens is about average thickness – not too thick or too thin. Point the lenses of this eye model at objects that are different distances away. Record the results below by stating the approximate distance from the eye and the quality of the image on the model retina. For image quality you may use phrases such as “sharp”, “slightly blurred”, and “very blurred”.

◆? Repeat the experiment recording the distance and image quality, this time with a shorter distance from the lens to the retina. You can do this by turning the hemisphere with the retina backwards so that it is closer to the lenses.

### ***Exploring vision defects with computer simulations***

The computer eye model allows you to move the location of the retina and, thus, create an eye model with a vision defect. You create the vision difficulties by moving the retina.

◆? First, move the retina to the location farthest from the lens. Now move the objects so that they are many different distances from eye. Record the results below by stating the distance from the eye and the quality of the image on the model retina. For image quality you



may use phrases such as “sharp”, “slightly blurred”, and “very blurred”. Also, make note of where the focal point is in relation to the retina (e.g. behind or in front).

◆? Now, move the retina to the position that is close to the lens. Repeat the experiment recording the distance and image quality and focal point location.

? From your experiences with the model and simulation, how would you describe nearsightedness and farsightedness and what causes each of them?

### ***Explaining Vision Defects***

The explorations indicated that common vision problems arise because the eye ball is either longer or shorter than normal. As a result we can see objects in a limited range of the distances that we would like to see. A perfect eye – one with no vision defects – is one that is very spherical in shape. However, as you saw with the model and the

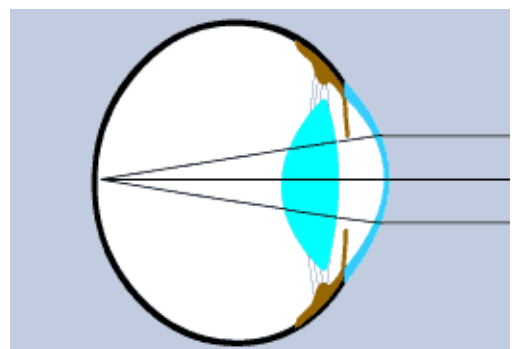

computer simulation, when the eye is shaped even slightly different, our vision changes drastically.

### **Hyperopia (Farsightedness)**

As you saw, in this situation the eyeball is abnormally short or has a lens with a lower refracting power than normal. The result is that the focal point lies behind the retina. The light that reaches the retina is not focused there, and so the image is blurred. In this case the eye is better able to see distant objects because these objects focus close to the retina. The name farsighted comes from this observation.

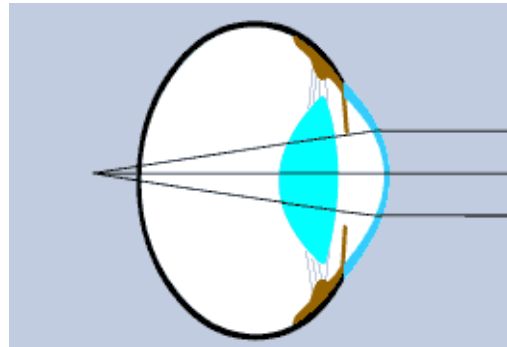

### **Myopia (Nearsightedness)**

As you saw, the eye that is longer than normal has better vision for objects that are near to it than for ones that are far away. This type of defect is called nearsightedness or myopia. In this case, the image focuses in front of the retina, and so the image on the retina is blurry.

For objects that are close to the eye, this condition is pronounced. Thus, when a person with myopia looks at very near objects, he/she sees somewhat clearly, and hence this condition is given the name nearsightedness.

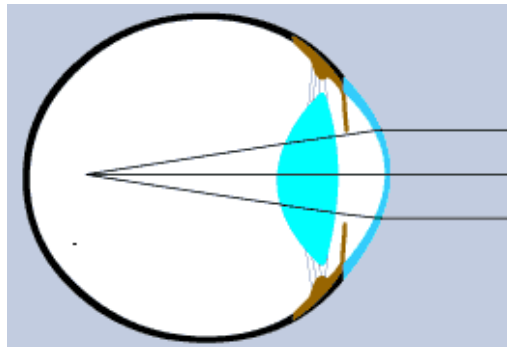

Photos from <http://www.blue-eye-divers.ch/index.php?page=10.20>

### **Astigmatism**

Astigmatism, which we have not explored yet, occurs when the cornea does not have a spherical shape. In most cases, the curvature in one direction is different from the curvature in another. The shape of the cornea in an astigmatic eye is likely to be similar in shape to an American football or a rugby ball rather than a European football (soccer ball) or a basketball.

The result of the different curvatures is that the eye has more than one place where the image focuses. Because of the lack of symmetry in the lens, a person with astigmatism cannot see any objects clearly. This condition is frequently accompanied by one of the other eye conditions.

### **Other defects**

Many other conditions can cause vision difficulties. However, these three are the ones that are most closely related to the optical properties of the eye. For a rather complete list of eye conditions see <http://www.stlukeseye.com/Conditions/Default.asp>. Many graphical representations of eye defects are also available on the web, for example see <http://www.tehranlasik.com/diseases/mupia%20.htm> and [www.eyeny.com/eye/index.shtml](http://www.eyeny.com/eye/index.shtml)

### ***Accommodation and Vision Defects***

Accommodation also plays a role in vision defects and can help us partially adjust to abnormal vision. To see how this attribute improves our vision, even with less-than-perfect

vision we will do some experiments with the model of the eye and a lens that can vary its thickness. The lens on our model varies through the addition of water through a syringe. As we discussed above, this process is *not* the way our eye works, but it provides a simple working model and demonstrates the principle.

◆? First, we will see how the adjustable lens models accommodation. Start with a thin lens, a normal eye, and an object that is in focus. Move the object until it is no longer in focus on the retina. Then, adjust the thickness of the lens until the object comes back into focus. Describe what you changed and how that change affected the image. Explain where the focal point of the image was in comparison with the retina of the eye.

? Repeat this process with a nearsighted and farsighted eye. In each case, describe the range over which you can keep an object in focus:

Nearsighted eye

Farsighted eye

## **Optical Corrections for vision defects**

### ***Hyperopia (Farsightedness)***

◆? Set the simulation for a farsighted eye. If you have forgotten what change to make, refer back to the discussion of eye defects. As you know, a corrective lens such as eye glasses or contact lens sit in front of the eye. This lens must do something to cause the light to focus on the retina. Just by looking at the model and the simulation, describe how the lens must change the light so the focus is on the retina.

◆? Try to make the corrections for the simulation. Describe the results and the properties of the lenses that work.

***Myopia (Nearsightedness)***

◆? Now set the simulation for nearsightedness. Predict what the lens will need to do to create an in-focus image on the retina.

◆? Try the simulation. Describe how the corrective lens is different from the one in the case of farsightedness.

In the case of farsightedness we needed to cause the light to focus in a shorter distance than usual. Then, the image would appear on a retina which is closer to the eye's lens than normal. This type of lens is called a converging lens. As its name implies, it causes the light to converge and focus. For nearsightedness we needed a lens that caused the light to diverge a little and focus in a longer distance than normal. Thus the lens that you used was a diverging lens. These results are summarized in the figure below.

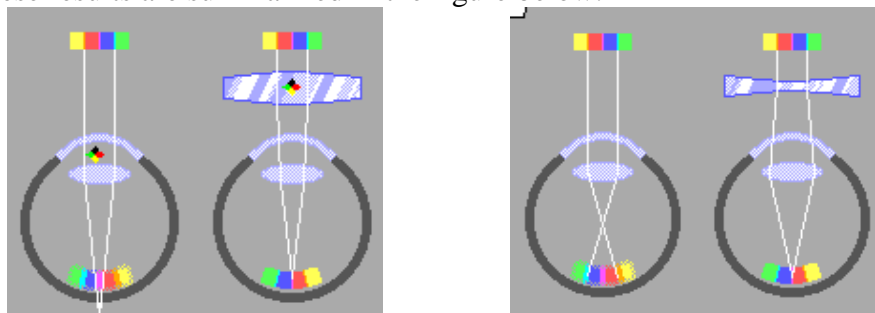

(<http://www.innerbody.com/image/nerv10.html>)

As you saw from the simulation with lenses, the converging lens is thicker in the middle than it is on the edges, while the diverging lens is thicker on the edges. You can learn more about why these types of lenses work if you study more about optics.

You may be thinking that the lens that we used to diverge the light rays was somewhat different from any that you have seen in eye glasses – even your grandfather’s glasses. And, it is. Our lens is the simplest form of a diverging lens. It works for objects that are straight in front of it only. For real glasses the lens itself needs to curve so that the optical corrections work when we look at objects off to the side. The drawings in Figure 9 show the shapes of typical converging and diverging lenses for eye glasses. The lenses for a myopic (nearsighted) eye are thinner in the middle, but that shape is more difficult to notice because of the curved shape of the lens. If you would like to manipulate some of the properties in these lenses, try the simulation: <http://thierry.baudart.waika9.com/unifocal/doc/index.htm>

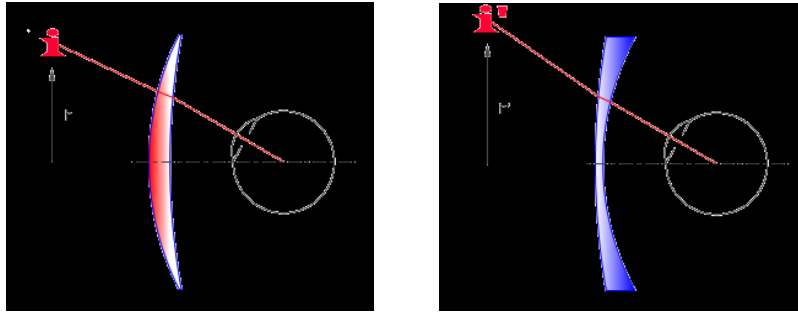

<http://thierry.baudart.waika9.com/unifocal/doc/index.htm>

## Beyond Lenses ...

Corrective lenses were apparently first used sometime around the year 1200. By the middle 1300s eye glasses that sit on the noses of the users were appearing in paintings. Developments in various types of frames and in the quality and materials of the lenses have continued for the last 800 plus years. However, even with the advent of contact lenses the basic solution to vision problems has remained the same – put a corrective lens in front of the eye.

Both the corrective procedures and the methods for determining those corrections are changing rapidly at this time. Surgery to make corrections to eye defects, primarily by changing the shape of the cornea, is still somewhat controversial but is also rather common. Next time, we will talk more about these new techniques.